

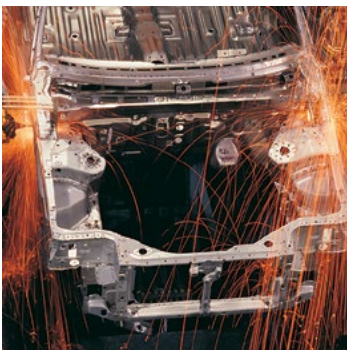

aerospace
climate control
electromechanical
filtration
fluid & gas handling
hydraulics
pneumatics
process control
sealing & shielding



Heavy Duty Hydraulic Cylinders

Series 2H / 2HD & 3H / 3HD



ENGINEERING YOUR SUCCESS.

Parker Hannifin's Industrial Cylinder Division offers products that are designed to meet and exceed the most demanding application requirements. Our extensive product line offers OEM's and End Users hydraulic and pneumatic cylinder solutions that provide value through reduced maintenance, increased productivity, and long service life. Parker Industrial Cylinder's wide breadth of product encompasses NFPA, ISO, and Custom designed products in a multitude of configurations and sizes.



Series CHE

- 20 through 100mm Bore Sizes
- Stroke Lengths to 150mm
- Operating Pressure to 140 bar
- 4 Different Rod Ends Available

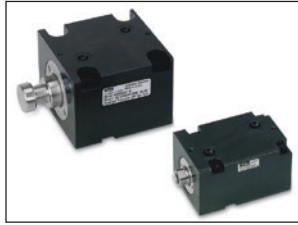

Series CHD

- 20 through 80mm Bore Sizes
- Stroke Lengths to 100mm
- Operating Pressure to 207 bar
- 4 Different Rod Ends Available

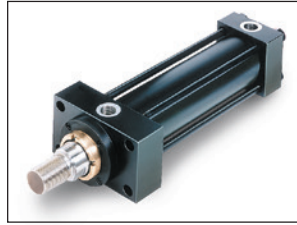

Series HMI

- Bore Sizes 25 through 200mm
- ISO 6020/2 Interchangeable
- 12 Standard Mounting Styles
- 210 Bar Hydraulic Service

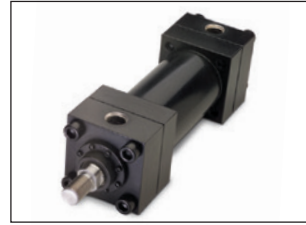

Series MH

- 1.50" through 14.00" Bore
- Heavy-Duty Service – Mill Type Construction
- 13 Mounting Styles Available
- 2,000 psi Hydraulic Service



Series 3L

- Bore Sizes 1.00" through 8.00"
- Removable Rod Gland
- 15 Standard Mounting Styles
- 1,000 psi Nominal Hydraulic Service



WaveScale

- Bore Sizes 2.00" through 8.00"
- LDT Feedback
- Integrated Manifolds Available
- Protective Covers Available



Series 2A

- 1.00" through 20.00" Bore
- 3 Standard Rod Ends/Specials to Order
- 15 NFPA Mounting Styles
- 250 psi Air Service



Series VE

- 2.00" through 24.00" Bore
- 3 Standard Rod Ends/Specials to Order
- Aluminum/Steel/Composite Tube
- 150 psi Air/Water Service



Series MA

- 1.50" through 6.00" Bore
- 11 Mounting Styles
- NFPA Interchangeable
- 200 psi Air Service



Series VH

- 2.50" through 8.00" Bore
- 13 Standard Mounting Styles
- Larger Ports Than Standard
- 3,000 psi Hydraulic Service



Custom Cylinder

- Bore Sizes to 42.00"
- Stroke Lengths to 70'
- Operating Pressure to 10,000 psi
- Third Party Agency Approval

In line with our policy of continuing product improvement, specifications and information contained in this catalog are subject to change. Copyright ©2009-2015 by Parker Hannifin Corporation. All rights reserved. PRINTED IN THE U.S.A.

⚠ WARNING

FAILURE OR IMPROPER SELECTION OR IMPROPER USE OF THE PRODUCTS AND/OR SYSTEMS DESCRIBED HEREIN OR RELATED ITEMS CAN CAUSE DEATH, PERSONAL INJURY AND PROPERTY DAMAGE.

This document and other information from the Parker Hannifin Corporation, its subsidiaries and authorized distributors provide product and/or system options for further investigation by users having expertise. It is important that you analyze all aspects of your application, including consequences of any failure and review the information concerning the product or system in the current product catalog. Due to the variety of operating conditions and applications for these products or systems, the user, through its own analysis and testing, is solely responsible for making the final selection of the products and systems and assuring that all performance, safety and warning requirements of the application are met.

The products described herein, including without limitation, product features, specifications, designs, availability and pricing, are subject to change by Parker Hannifin Corporation and its subsidiaries at any time without notice.

Offer of Sale

The items described in this document are hereby offered for sale by Parker Hannifin Corporation, its subsidiaries or its authorized distributors. This offer and its acceptance are governed by provisions stated on a separate page of the document entitled 'Offer of Sale'.



Table of Contents

Series 2H Heavy Duty Hydraulic Cylinders

pages 1-30

Performance	2	HB Mount Dimensions	17
Specifications and Mounting Styles	3	HH Mount Dimensions	18
Features and Benefits	4, 5	C Mount Dimensions	19
Application Check List	6	F Mount Dimensions	20
Mounting Styles & Tips for Applying Them	7	BB Mount Dimensions	21
2H Cylinder Model Code / How to Order	8, 9	D Mount Dimensions	22
Rod End Styles and Dimensions	10, 11	DB Mount Dimensions	23
TD, T, TB, TC Mount Dimensions	12	DD Mount Dimensions	24
J Mount Dimensions	13	DE Mount Dimensions	25
JB Mount Dimensions	14	SB Mount Dimensions	26
JJ Mount Dimensions	15	Double Rod Cylinders	27
H Mount Dimensions	16	2HD & 3HD Bolt-On Gland Option	28-30

A

Series 3H Heavy Duty Hydraulic Cylinders

pages 31-64

	7.00" & 8.00"	10.00-20.00"		7.00" & 8.00"	10.00-20.00"
Performance	32	32	JB Mount Dimensions	44	56
Specifications	33	33	JJ Mount Dimensions	45	54, 55
Specifications, Mounting Styles	34	35	C Mount Dimensions	46	59
3H Cylinder Model Code & How to Order	36, 37	36, 37	F Mount Dimensions	46	-
Rod End Styles and Dimensions	38	39	BB Mount Dimensions	47	60
TD, TB, TC Dimensions	40	53	D Mount Dimensions	48	61
H Mount Dimensions	41	-	DB Mount Dimensions	49	62
HB Mount Dimensions	42	58	DD Mount Dimensions	50	63
HH Mount Dimensions	42	57	DE Mount Dimensions	51	-
J Mount Dimensions	43	-	Double Rod Cylinders	52	64

B

Cylinder Accessories and Replacement Parts

pages 65-82

2H & 3H Cylinder Mounting Accessories	66-69	Piston Seal Kits for Series 2H with Magnetic Piston Option ..	79
2H Spherical Bearing Mounting Accessories	70	Gland Cartridge Wrenches	79
2H & 3H Linear Alignment Couplers	71, 72	3H Parts List and Seal Kits for 10.00" - 20.00" Bore	80, 81
Split Couplers and Weld Plates for Style 55 Piston Rod End ..	73	2HD/3HD Parts List and Seal Kits	82
Dual Axis Knuckle	74		
2H Parts List and Seal Kits	76, 77		
3H Parts List and Seal Kits for 7.00" & 8.00" Bore	78		

C

Custom Modifications

pages 83-96

Water Submersible Options	84, 85	Gland Drain	90
Hi Load Piston	86, 87	Air Bleed Ports	90
Low Friction Seals	88, 89	Tie Rod Supports	91
Common Modifications:		Stroke Adjusters	91
Metallic Rod Wiper	90	Thrust Key Mountings	91
Parker Crown Wiper™	90	Metric Piston Rod Thread	91
Rod End Boots	90	End of Stroke Proximity Switches	92-95

D

Engineering Data

pages 97-120

Theoretical Push and Pull Forces	98, 99	Cushioning	110-115
Cylinder Weights	100	Manufacturing Locations	117
Operating Fluids and Seals / Temperature Range	101	Cylinder Safety Guide	118, 119
Fluids and Temperature Range / Pressure Ratings	102	Offer of Sale	120
Ports	103, 104		
Stroke Data / Mounting Groups	105		
Stop Tubing	106		
Piston Rod Selection Data	107-109		

E





With annual sales of \$13 billion in fiscal year 2014, Parker Hannifin is the world's leading diversified manufacturer of motion and control technologies and systems, providing precision-engineered solutions for a wide variety of mobile, industrial and aerospace markets. The company employs approximately 57,500 people in 50 countries around the world. Parker has increased its annual dividends paid to shareholders for 58 consecutive fiscal years, among the top five longest-running dividend-increase records in the S&P 500 index. For more information, visit the company's website at www.parker.com or its investor information website at www.phstock.com.

Parker is Engineering

Fluid Power and application expertise provide customers the opportunity to use us as an extension of their design teams.

From new system design to improvements required for existing applications, Parker offers unparalleled engineering expertise. We'll help you develop cost saving, high performance solutions that provide value through increased productivity, improved machine efficiency, and reduced downtime.

Our design engineers utilize the highest quality materials and cutting edge manufacturing processes available to push the envelope for performance, value and reliability.

Parker components and systems are made to last. We offer complete system solutions for the following industries:

- Plastics
- Metal Forming
- Steel
- Press
- Off Shore Oil
- Forestry
- Mining
- Entertainment
- Flight Simulation
- Fatigue Testing
- Automation

Worldwide Supplier to Industrial Markets

Parker Hannifin is the world's leading supplier of motion and control technologies that include; motion control products, systems, and complete engineered solutions for industrial markets. Parker's broad and extensive breadth of product

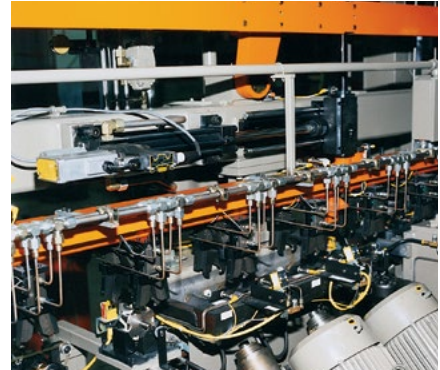

offer single source capability with limitless possibilities. Our industrial product solutions range from state of the art stand-alone components to complete engineered systems that are designed to provide value and efficiency to all of our customers. Each component and system is backed up with superior application expertise and technical support that you would expect from Parker Hannifin.



Series 2H/3L Magnetic Piston

Position Sensing Technology
for Hydraulic Cylinders

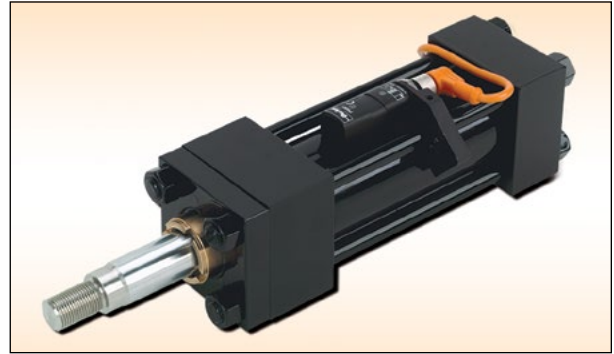

Series 2H Cylinder – with Hi-Load magnetic piston

Durable polyurethane bi-directional seal – for positive sealing with no by-pass and long life.

WearGard™ wear band – improves resistance to bearing loads and provides support for magnet.

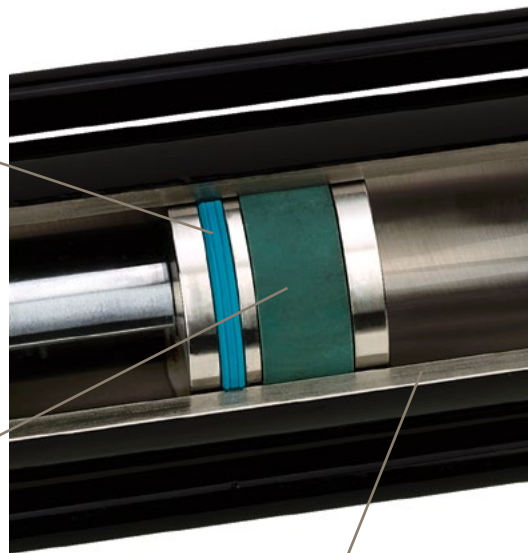

Cylinder Body – Standard steel material for ALS Switch or 316 stainless steel for conventional solid state or reed switches.

Customer Value Proposition:

Parker's magnetic sensing option for hydraulic steel/tie rod construction cylinders provides OEM's and end users the ability to sense piston position in an economical and reliable fashion through the use of innovative magnet and switching technology. The magnetic piston option offers all users the choice to eliminate added cylinder

machining costs, stand alone external brackets/hardware, and reduced system set-up time. By incorporating sensing capability into steel/tie rod style cylinders, the need to fabricate, install, wire, and adjust stand alone proximity switches can be eliminated – thus providing a clean and more efficient position monitoring system.

Product Features:

- Available for Series 2H, 3L, and 2A cylinders
- 1.50" through 6.00" bore Series 2H pistons
- Available on 15 different mounting styles
- Adjustability over the entire working stroke length
- Multiple switches can be used per cylinder
- Non intrusive design eliminates potential leakage

Magnetic Switch Choices

Making The Best Choice
Parker's ALS Switch and Global Switch are designed to offer customers an alternative means of sensing hydraulic cylinder piston position. Depending on the application, and the budget, one switch type may be better suited to fulfill customer needs than the other. Some of the important things to consider when analyzing what switch to choose are listed at right.

- Can be positioned at any location along the cylinder to indicate end-of-stroke or mid-stroke locations.
- Allow multiple switches to be installed with numbers only restricted by available tie rod mounting space.
- Available in 1.50" - 6.00" bores.

Technology Comparison

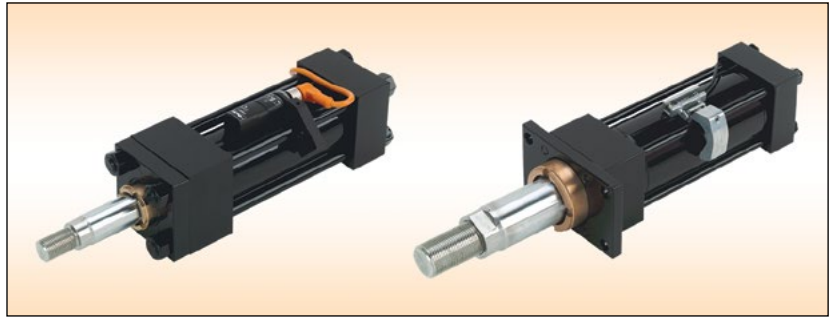

ALS Switch

- Compatible with standard steel tube
- +10 to +30 VDC power requirement
- PNP/NPN wired NO or NC
- Solid state construction
- 2 LED indicators (power & target)
- 12mm connector
- IP 67 rated
- Temperature Range: -25°C to +85°C
- Short circuit protection

Global Switch

- Uses 316 stainless steel tube
- +10 to +30 VDC, +10 to +120 VAC power requirement
- PNP/NPN, Reed
- Solid state construction
- 1 power LED indicator
- 12mm or 8mm connector, flying leads
- IP 68 rated
- Temperature Range: -25°C to +75°C
- Short circuit protection

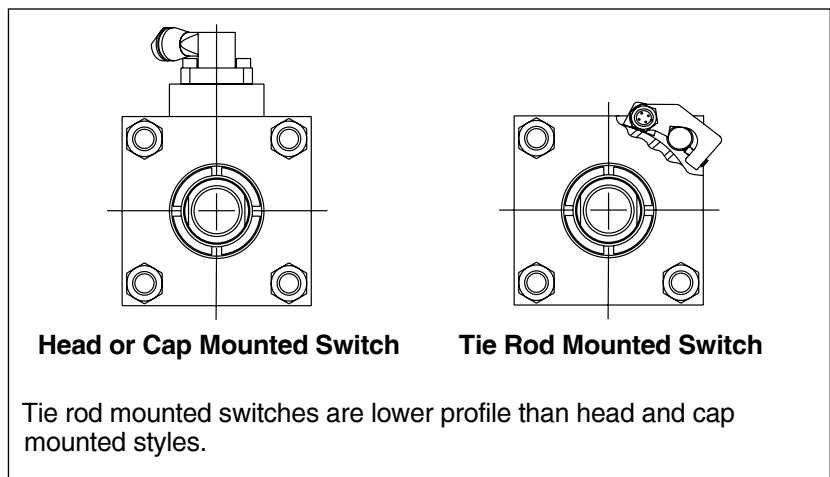

Extreme High Temperature Seal Option – Up to 400°F

For Series 2H/2HD, 3H/3HD, 2A and 3L Cylinders



Customer Value Proposition:

Parker's Extreme High Temperature Seal Option will provide OEM's and End Users an increase in machine productivity through improved resistance to heat degradation as compared to typical fluorocarbon seals. With a maximum continuous temperature rating of 400° F, the Extreme High Temperature Seal Option will allow longer service life in applications that require the use of alternative fluid types and demand superior heat resistance. Parker's innovative seal design utilizes PTFE materials that are constantly energized to provide excellent seal performance and long life. Customers utilizing this design will realize a reduction in machine downtime due to seal failure associated with high temperature exposure.

Product Features:

- Operating temperature to 400° F
- Broad range of fluid compatibility
- Available bore sizes: 1.50" through 8.00"; rod diameters 1.000" through 5.500"
- Stainless steel spring loads both dynamic and static piston seal lips
- No additional delivery time

Wiperseal – Unique profile of bronze filled PTFE wiperseal provides performance of a third rod seal while scraping contaminants from the piston rod as it retracts. A fluorocarbon energizer ensures constant contact of wiperseal to the piston rod.

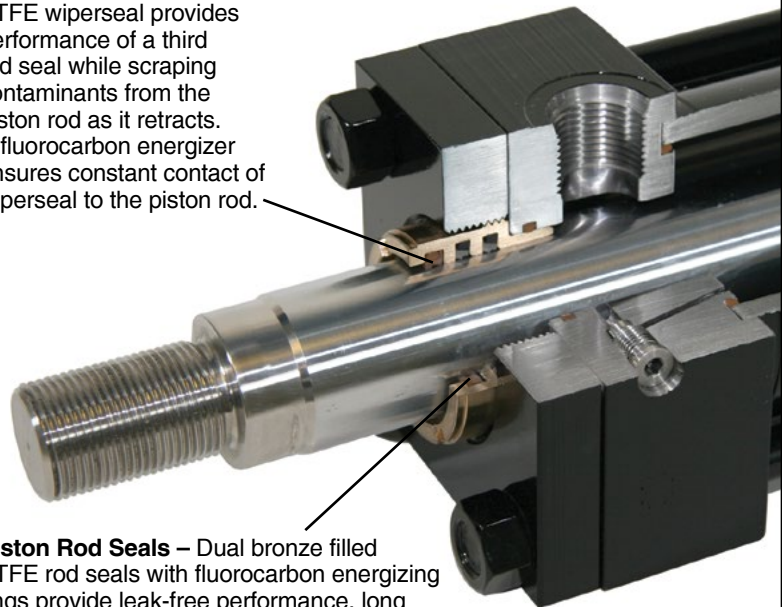

Piston Rod Seals – Dual bronze filled PTFE rod seals with fluorocarbon energizing rings provide leak-free performance, long life, and heat resistance to 400° F.

Cylinders for High Temperature Applications

When your customer demands a long life cylinder with outstanding heat resistance, look no further than Parker's new Extreme High Temperature Seal option.

Filled PTFE piston seals, rod seals, and wiperseal provide maximum resistance to extreme heat (up to 400° F) with excellent service life.

PTFE seals are mechanically energized to maintain uniform contact to dynamic sealing surfaces for positive leak-free performance across the entire operating pressure range. Static seals are fluorocarbon for a complete heat resistant assembly.

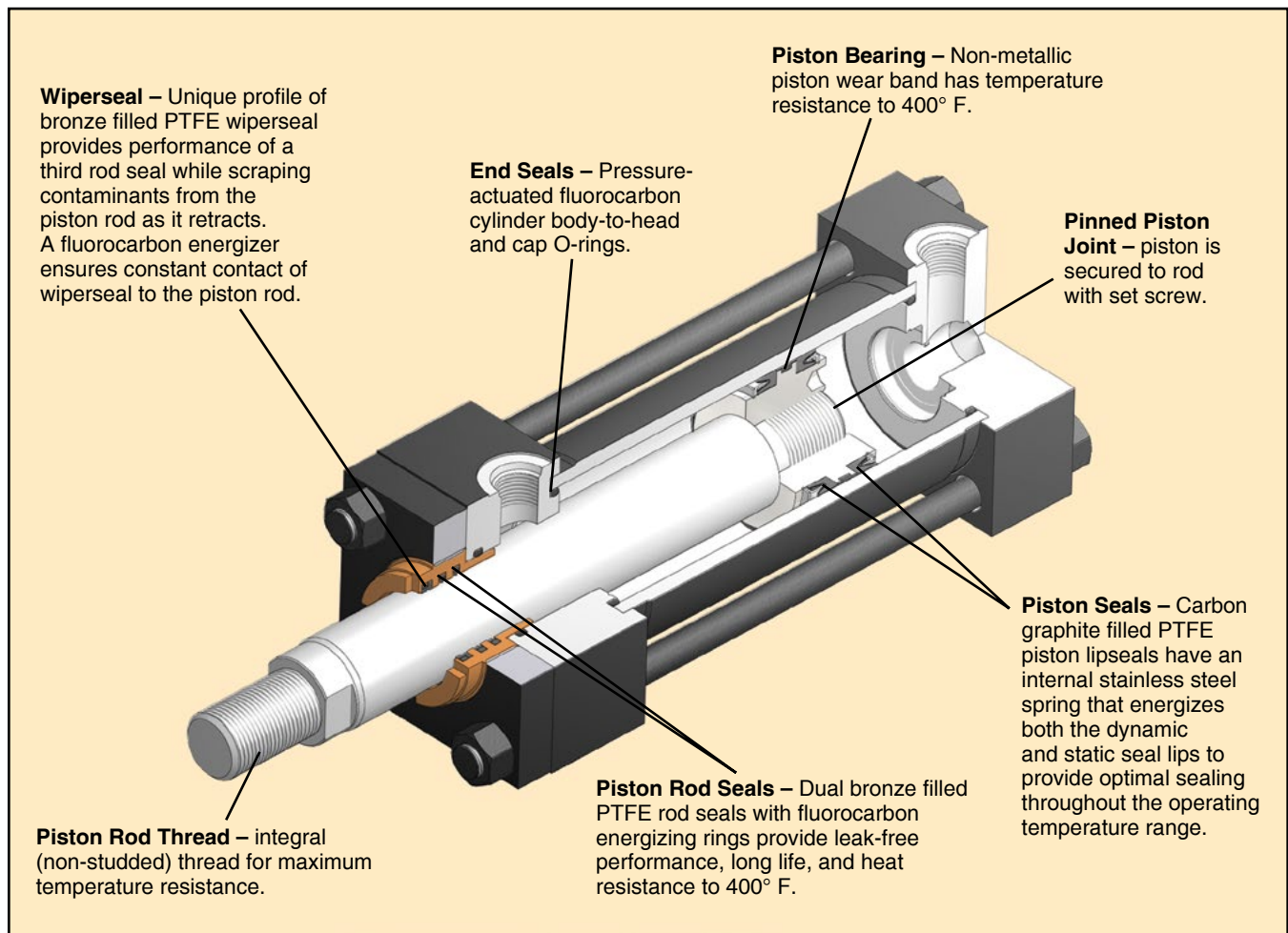

Parker Crown™ Wiper

Parker introduces an advanced particulate contaminant exclusion system by offering the Parker Crown™ Wiper for Series 2HD and 3HD Piston Rod Cylinders.

Abrasive particulate can cause significant wear to precision components when it enters the cylinder and migrates into the hydraulic system. The Parker Crown Wiper is extremely effective in keeping contamination out of the cylinder to prevent it from shortening the actuator and system service life. Parker Hannifin Corporation showcases its commitment to reducing hydraulic system problems with the Crown Wiper. This innovative solution goes a long way toward improving equipment operation, lowering costs, extending component life and machine availability.

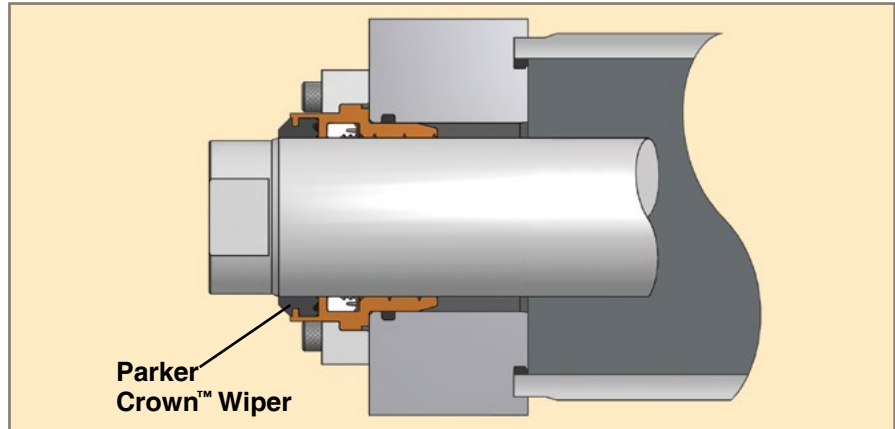

- The sharp leading edge cleans the piston rod on the retract stroke
- The Crown Wiper acts as a secondary seal by wiping away any oil film adhering to it on the extended stroke
- Durable polyurethane material works well for both Seal Class 1 and 2 Service
- Available in fluorocarbon material for Class 5 service in elevated temperatures
- Beveled design sheds abrasive contamination away from the gland
- Requires a unique gland that is offered on Series 2HD and 3HD
- Available in rod diameters 0.625" - 5.500"
- Does not change cylinder mounting dimensions

Water Submersible Option

Parker Hannifin Industrial Cylinder Division Water Submersible Option for Series 2H and 3H Hydraulic Cylinders is the right choice for your underwater application. With options for a submersible depth of up to 5,000 feet, corrosion resistant materials and surface treatments these cylinders will stand up to the challenge.

Standard options include 17-4 PH stainless steel tie rods, Bumax 88 stainless steel tie rod nuts and chrome plated body ID. Surface treatments for corrosion protection consist of electroless nickel plated exterior, inorganic zinc primer and epoxy undercoat and topcoat. Custom options like end-of-stroke switches and all stainless steel construction are available by special order.

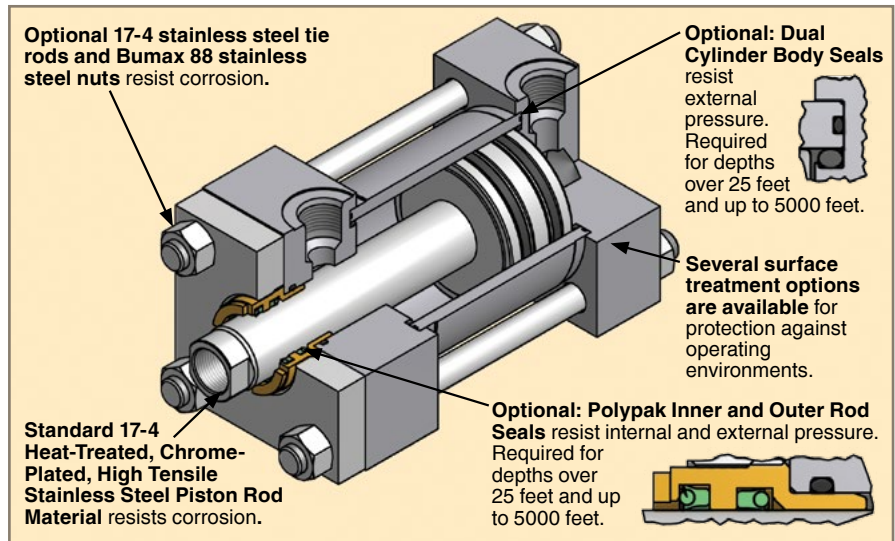

- Submersion Depth – up to 5000 feet
- Heavy Duty Service – ANSI (NFPA) T3.6.7R2 – 1996 Specifications and Mounting Dimension Standards
- Nominal Pressure – 3000 psi
- Operating Temperature – -10°F to +165°F
- 17-4 PH chrome plated stainless steel piston rod
- Stainless steel name tag affixed with stainless steel wire around tie rod
- Standard Rod Seal and Body Seal Construction for up to 25 feet
- Subsea Seal Packages for over 25 feet to 5000 feet

Manufacturing Locations



Corona, California

221 Helicopter Circle • Corona, CA 92880 • Tel.: (951) 280-3800
Fax: (951) 280-3808 • Fax: (800) 869-9886



Enfield, Connecticut

80 Shaker Road • Enfield, CT 06082 • Tel.: (860) 749-2215
Fax: (800) 323-0105



Atlanta, Georgia

1300 Six Flags Road • Lithia Springs, GA 30122
Tel.: (770) 819-3400 • Fax: (800) 437-3498



Goodland, Indiana

715 South Iroquois Street • Goodland, IN 47948
Tel.: (219) 297-3182 • Fax: (800) 328-8120



Plymouth, Michigan

900 Plymouth Road • Plymouth, MI 48170
Tel.: (734) 455-1700 • Fax: (734) 455-1007



Eugene, Oregon

29289 Airport Road • Eugene, OR 97402-0079
Tel.: (541) 689-9111 • Fax: (541) 688-6771 • Fax: (800) 624-7996

Section A

Series 2H Heavy Duty Hydraulic Cylinders 1.50" Through 6.00" Bore

Performance	2
Specifications and Mounting Styles	3
Features and Benefits	4, 5
Application Check List	6
Mounting Styles & Tips for Applying Them	7
2H Cylinder Model Code / How to Order	8, 9
Rod End Styles and Dimensions	10, 11
TD, T, TB, TC Mount Dimensions	12
J Mount Dimensions	13
JB Mount Dimensions	14
JJ Mount Dimensions	15
H Mount Dimensions	16
HB Mount Dimensions	17
HH Mount Dimensions	18
C Mount Dimensions	19
F Mount Dimensions	20
BB Mount Dimensions	21
D Mount Dimensions	22
DB Mount Dimensions	23
DD Mount Dimensions	24
DE Mount Dimensions	25
SB Mount Dimensions	26
Double Rod Cylinders	27
2HD & 3HD Bolt-On Gland Option	28-30



Parker Series 2H Heavy Duty Hydraulic Cylinder

Series 2H cylinders set the standard for performance, durability, and trouble free operation. Parker superior design, the use of high quality materials and stringent manufacturing practices provide all customers with long cylinder service life and reduced operating costs. Design features such as the “Jewel” rod gland, hard chrome plated piston rods, and stepped cushions provide increased machine productivity through reduced downtime, faster cycle times, and improved system efficiency. Every Parker cylinder is individually tested before leaving our plant to assure proper performance and leak free operation. All Parker Cylinder products carry an eighteen month warranty.

Select Parker Series 2H cylinder for your hydraulic cylinder requirements. Parker Series 2H will provide the value and performance you need for all of your industrial hydraulic application demands.

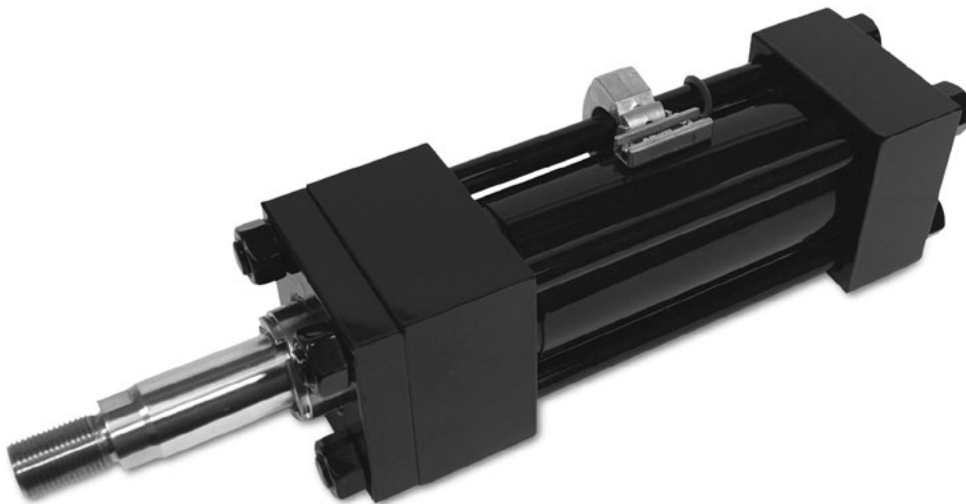

Standard Specifications

- Heavy Duty Service – ANSI/(NFPA) T3.6.7R3 - 2009 Specifications and Mounting Dimension Standards
- Standard Construction – Square Head – Tie Rod Design
- Nominal Pressure – 3000 psi¹
- Standard Fluid – Hydraulic Oil
- Standard Temperature – -10°F to +165°F²
- Bore Diameters – 1.50" through 6.00" (Larger sizes available)

In line with our policy of continuing product improvement, specifications in this catalog are subject to change.

Note: Series 2H Hydraulic Cylinders fully meet ANSI/(NFPA) T3.6.7R3 - 2009 Specifications and Mounting Dimension Standards for Square Head Industrial Fluid Power Cylinders.

- Piston Rod Diameter – .625" through 4.000"
- Mounting Styles – 18 standard styles at various application ratings
- Strokes – Available in any practical stroke length
- Cushions – Optional at either end or both ends of stroke. "Float Check" at cap end.
- Rod Ends – Four Standard Choices – Specials to Order

¹ If hydraulic operating pressure exceeds 3000 psi, send application data for engineering evaluation and recommendation. See Section E for actual design factors.

² See Section E for higher temperature service.



Available Mounting Styles

<p>Basic Style T 1.50" - 6.00"</p> <p>(NFPA MX0)</p>	<p>Tie Rods Extended Head End Style TB 1.50" - 6.00"</p> <p>(NFPA MX3)</p>	<p>Tie Rods Extended Cap End Style TC 1.50" - 6.00"</p> <p>(NFPA MX2)</p>	<p>Tie Rods Extended Both Ends Style TD 1.50" - 6.00"</p> <p>(NFPA MX1)</p>
<p>Head Rectangular Flange Style J 1.50" - 6.00"</p> <p>(NFPA MF1)</p>	<p>Head Square Flange Style JB 1.50" - 6.00"</p> <p>(NFPA MF5)</p>	<p>Head Rectangular Style JJ 1.50" - 6.00"</p> <p>(NFPA ME5)</p>	<p>Cap Rectangular Flange Style H 1.50" - 6.00"</p> <p>(NFPA MF2)</p>
<p>Cap Square Flange Style HB 1.50" - 6.00"</p> <p>(NFPA MF6)</p>	<p>Cap Rectangular Style HH 1.50" - 6.00"</p> <p>(NFPA ME6)</p>	<p>Side Lug Style C 1.50" - 6.00"</p> <p>(NFPA MS2)</p>	<p>Side Tapped Style F 1.50" - 6.00"</p> <p>(NFPA MS4)</p>
<p>Cap Fixed Clevis Style BB 1.50" - 6.00"</p> <p>(NFPA MP1)</p>	<p>Head Trunnion Style D 1.50" - 6.00"</p> <p>(NFPA MT1)</p>	<p>Cap Trunnion Style DB 1.50" - 6.00"</p> <p>(NFPA MT2)</p>	<p>Intermediate Fixed Trunnion Style DD 1.50" - 6.00"</p> <p>(NFPA MT4)</p>
<p>HD Intermediate Fixed Trunnion Style DE 4.00" - 6.00"</p> <p>(NFPA MT4)</p>	<p>Spherical Bearing Style SB 1.50" - 6.00"</p>	<p>Double Rod Cylinders Style KT Shown 1.50" - 6.00"</p> <p>Most of the above illustrated mounting styles are available in double rod cylinders.</p>	

The inside story on why Series 2H is your best choice in heavy duty hydraulic cylinders

Align-A-Groove – A $\frac{3}{16}$ " wide surface machined at each end of the cylinder body. Makes precise mounting quick and easy.

Ports – SAE "O" ring ports are standard.

Optional Ports

Ports – NPTF ports are optional at no extra charge. Oversize NPTF and SAE ports are available at extra charge.

Primary Seal – TS-2000 Rod Seal is a proven leakproof design – completely self-compensating and self-relieving to withstand variations and conform to mechanical deflection that may occur.

"Jewel" Rod Gland Assembly – Externally removable without cylinder disassembly. Long bearing surface is inboard of the seals, assuring positive lubrication from within the cylinder. An o-ring is used as a seal between gland and head, and also serves as a prevailing torque-type lock.

Secondary Seal – Double-Service Wiperseal™ wipes clean any oil film adhering to the rod on the extend stroke and cleans the rod on the return stroke.

Piston Rod Stud – Furnished on 2.000" diameter rods and smaller when standard style #4 rod end threads are required. Studs have rolled threads and are made from high strength steel. Anaerobic adhesive is used to permanently lock the stud to the piston rod.

Piston Rod – Medium carbon steel, induction case-hardened, hard chrome-plated and polished to 10 RMS finish. Piston rods are made from 85,000 to 100,000 psi minimum yield material in .625" through 4.000" diameters. Larger diameters vary between 57,000 and 90,000 psi minimum material, depending on rod diameter.

End Seals – Pressure-actuated cylinder body-to-head and cap o-rings.

Steel Head – Bored and grooved to provide concentricity for mating parts.

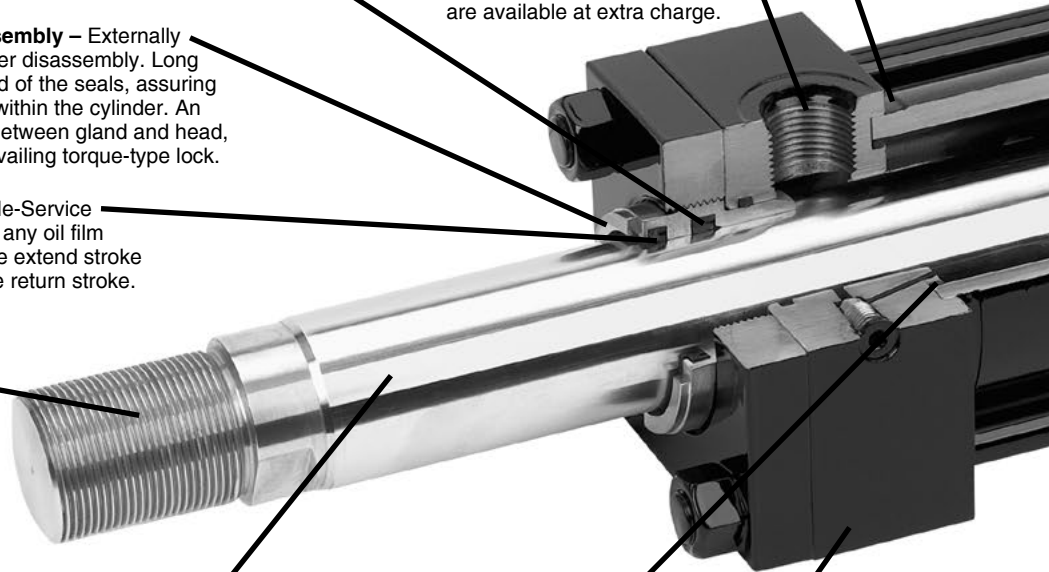

Parker's Exclusive Stepped floating cushions combine the best features of known cushion technology.

Deceleration devices or built-in "cushions" are optional and can be supplied at head end, cap end, or both ends without change in envelope or mounting dimensions. Parker cylinder cushions are a stepped design and combine the best features of known cushion technology.

Standard straight or tapered cushions have been used in industrial cylinders over a very broad range of applications. Parker research has found that both designs have their limitations.

As a result, Parker has taken a new approach in cushioning of industrial hydraulic cylinders and for specific load and velocity conditions have been able to obtain deceleration curves that come very close to the ideal. The success lies in a stepped sleeve or spear concept where the steps are calculated to approximate theoretical orifice area curves.

In the cushion performance chart, pressure traces show the results of typical orifice flow conditions. Tests of a three-step sleeve or spear show three pressure pulses coinciding with the

steps. The deceleration cushion plunger curves shape comes very close to being theoretical, with the exception of the last $\frac{1}{2}$ inch of travel. This is a constant shape in order to have some flexibility in application. The stepped cushion design shows reduced pressure peaks for most load and speed conditions, with comparable reduction of objectionable stopping forces being transmitted to the load and the support structure.

All Parker Hannifin cushions are adjustable.

The Series 2H cylinder design incorporates the longest cushion sleeve and cushion spear that can be provided in the standard envelope without decreasing the rod bearing and piston bearing strengths.

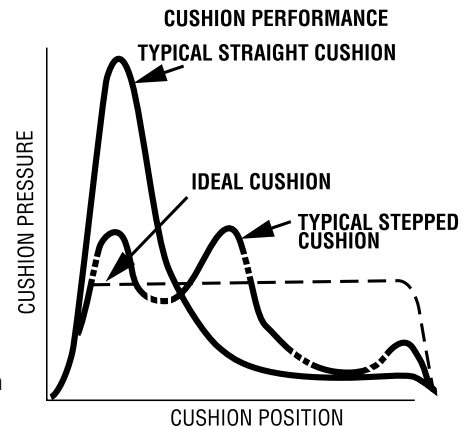

Adjustable Floating Stepped Cushions – For maximum performance – economical and flexible for even the most demanding applications – provides superior performance in reducing shock. Cushions are optional and can be supplied at head end, cap end, or both ends without change in envelope or mounting dimensions.

Steel Cap – Bored and grooved to provide concentricity for mating parts.

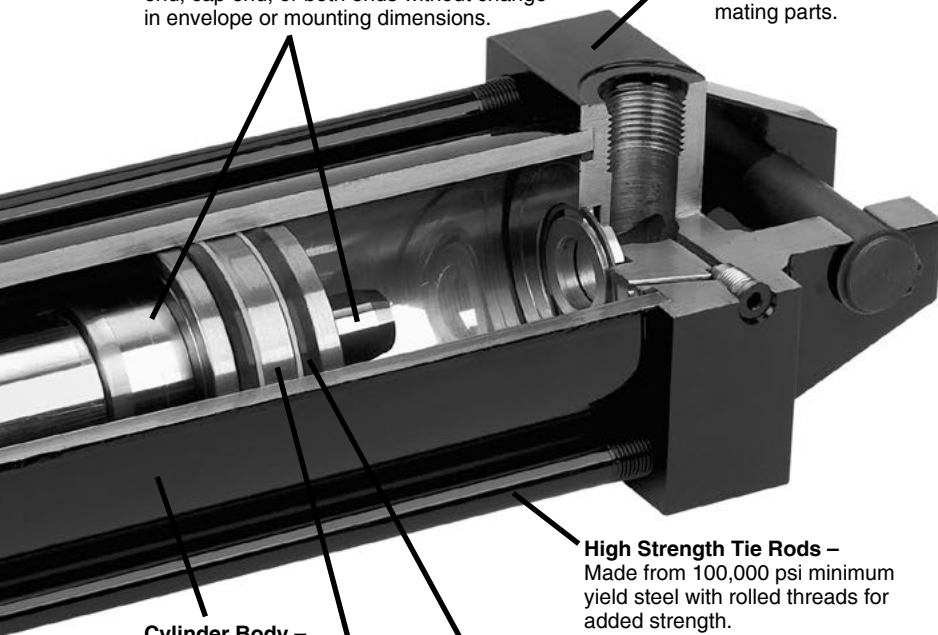

Cylinder Body – Heavy-wall steel tubing, honed to a micro finish bore.

Lipseal™ Piston – Zero leakage under static conditions for hydraulic pressures up to 3000 PSI. Seals are self-compensating to conform to variations in pressure, mechanical deflection, and wear. Back-up washer prevents extrusion.

One-Piece Nodular Iron Piston – The wide piston surface contacting cylinder bore reduces bearing loads. Anaerobic adhesive is used to permanently lock and seal the piston to the rod.

High Strength Tie Rods – Made from 100,000 psi minimum yield steel with rolled threads for added strength.

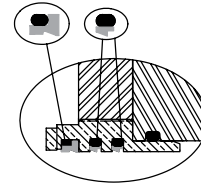

Optional High Temperature Gland – Dual filled PTFE rod seals and filled PTFE wiper seal are energized with fluorocarbon o-rings to maintain consistent contact with the piston rod. Excellent sealing performance produce dry rod on extend stroke with rod scraping to clean rod on retract. Combine with Spring Loaded PTFE Piston Seals for cylinder heat resistance to 400° F. See class 8 seal specification on Operating Fluids and Temperature Range page in Section E.

Optional Pistons

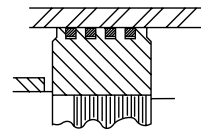

Step cut iron piston rings are optional at no extra charge.

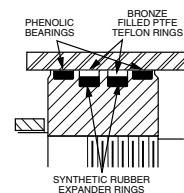

Hi Load Piston – Optional at extra charge. Includes wear rings and bronze-filled PTFE seals. Two wear rings serve as bearings which deform radially under side-loading, enabling the load to be spread over a larger area and reduce unit loading. Bronze-filled PTFE seals are designed for extrusion-free, leak-proof service and longer cylinder life than the lipseal type piston.

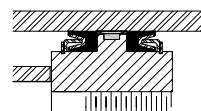

Spring Loaded PTFE Piston Seals

Optional filled PTFE piston Lipseals utilize an internal stainless steel spring to energize both the dynamic and static sealing lips to optimize seal performance throughout the operating temperature range. Non-metallic piston wear ring in 1.50"-6.00" bores (bronze in 7.00" & 8.00" bore 3H) reduces possibility of damaging piston which can score expensive tubing. Combine with High Temperature Gland for cylinder heat resistance to 400° F. See class 8 seal specification on Operating Fluids and Temperature Range page in Section E.

- (1) When a cushion is specified at the head end:
 - a. A self-centering stepped sleeve is furnished on the piston rod assembly.
 - b. A needle valve is provided that is flush with the side of the head even when wide open. It may be identified by the fact that it is socket-keyed. It is located on side number 2, in all mounting styles except D, DB, DD, DE, JJ, and HH. In these styles it is located on side number 3.
 - c. On 6.00" bore and larger cylinders a springless check valve is provided that is also flush with the side of the head and is mounted adjacent to the needle valve except on mounting style C, where it is mounted opposite the needle valve. It may be identified by the fact that it is slotted.
 - d. On 1.50" - 5.00" bore cylinders a slotted sleeve design is used in place of the check valve.

- e. 1.50" - 2.50" bore cylinders use a cartridge style needle valve (see Figure A).
- (2) When a cushion is specified at the cap end:
 - a. A stepped cushion spear is provided on the piston rod.
 - b. A "float check" self-centering bushing is provided which incorporates a large flow check valve for fast "out-stroke" action.
 - c. A socket-keyed needle valve is provided that is flush with the side of the cap when wide open. It is located on side number 2 in all mounting styles except D, DB, DD, DE, JJ, and HH. In these styles it is located on side number 3.

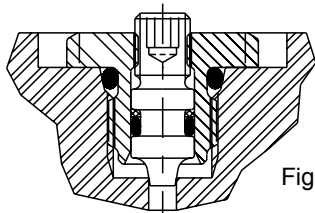
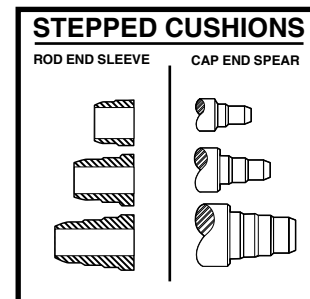

Figure A



Application Checklist

The following checklist should be used to select the best possible cylinder for a given application. Additional information can be referenced in the following pages to help assist in this process. In the event that you have additional questions or concerns, or if more information is required, please contact your local Parker distributor or our customer service representatives for assistance.

- 1. Establish the system requirements** Series 2H
 - How heavy is the load to be moved?
 - What is the nominal operating pressure of the system?
 - How far does the load have to move?
 - What is the speed at which the load will move?
 - What is the fluid type and the temperature to which the cylinder will be exposed?

- 2. Mounting Style** Page 7
 - Determine the best mounting style for the application.
 - If your application requires a mounting style that is not exactly matched by one of our catalog offerings, we can supply the mounting you need. If the required mounting resembles one of our standards, specify that style, enter 'S' in the Special Modification field and provide a dimension drawing of your mount. Special mounting styles that do not resemble a standard style will be designated as style TX by the factory.

- 3. Cylinder Bore and Operating Pressure** Page 98
 - Review the theoretical push and pull force for a given bore size to determine.

- 4. Piston Rod** Page 107
 - Determine what rod size will be required to avoid buckling.
 - Determine if a single or double rod cylinder is required.
 - Determine the rod end style and rod end thread.
 - Will stop tubing be required?

- 5. Piston Seals** Page 101
 - Determine the best seal type for your application.

Piston Lipseals can hold a load in position, but are not as durable as cast iron rings or Hi-Load seals. For applications with a working pressure in excess of 2000 psi, where the duty cycle requires sustained piston speeds in excess of 15 ips or high cycling performance, other seal options should also be considered. Where these performance criteria will be exceeded, please contact the factory with details of the application.
 - Select the proper seal type and configuration for the application.
 - Select the proper seal to assure fluid and temperature compatibility.

- 6. Cushioning** Page 110
 - Determine if cushions are required to safely stop the load.

- 7. Ports** Page 103
 - Select the best possible port size for a given speed requirement.
 - Select port position.

- 8. Piston rod and mounting accessories** Page 66
 - Determine how you will attach the cylinder to the load.

- 9. Custom modifications** Page 83

Mounting Styles & Tips for Applying Them

Extended Tie Rod Mountings – TB, TC, and TD

Application:

- Straight line force transfer
- Compression loads (push)
– use TC or TD
- Tension loads (pull)
– use TB or TD

Advantages:

- Ease of mounting in tight spaces
- Force is transferred along the centerline of the cylinder

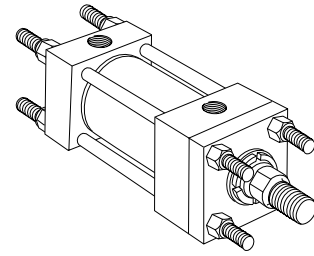

Flange Mountings – J, JB, JJ, H, HB, and HH

Application:

- Straight line force transfer
- Compression loads (push)
– use H, HB or HH
- Tension loads (pull)
– use J, JB, or JJ

Advantages:

- Rigid base mounting due to large flange area
- Force is transferred along the centerline of the cylinder

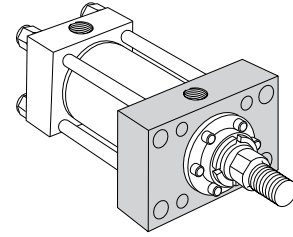

Side Tap Mounting – F / Side Lug Mounting – C

Application:

- Straight line force transfer
- Can be used in compression or tension loads
- Thrust key and secure mounting area are vital

Advantages:

- Ease of mounting

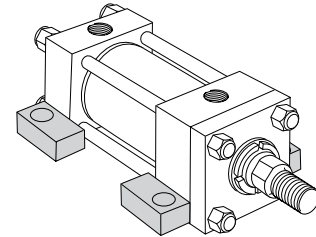

Pivot Mountings – BB and SB

Application:

- Curved or arc line force transfer
- Can be used in compression or tension loads
- Movement in a simple arc
– use BB mountings
- Movement in a compound arc
– use SB mountings

Advantages:

- Ease of mounting
- Design flexibility
- Self aligning (SB)

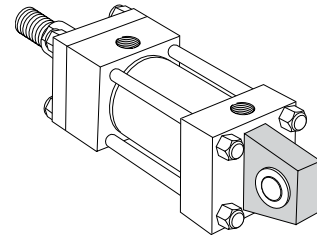

Trunnion Mountings – D, DB, DD and DE

Application:

- Curved or arc line force transfer
- Can be used in compression or tension loads
- Compression loads – use DB or DD, DE mountings
- Tension loads – use D, DD or DE mountings

Advantages:

- Ease of mounting
- Design flexibility
- Self aligning

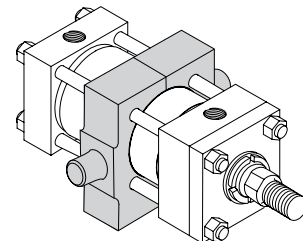

2H Model Code

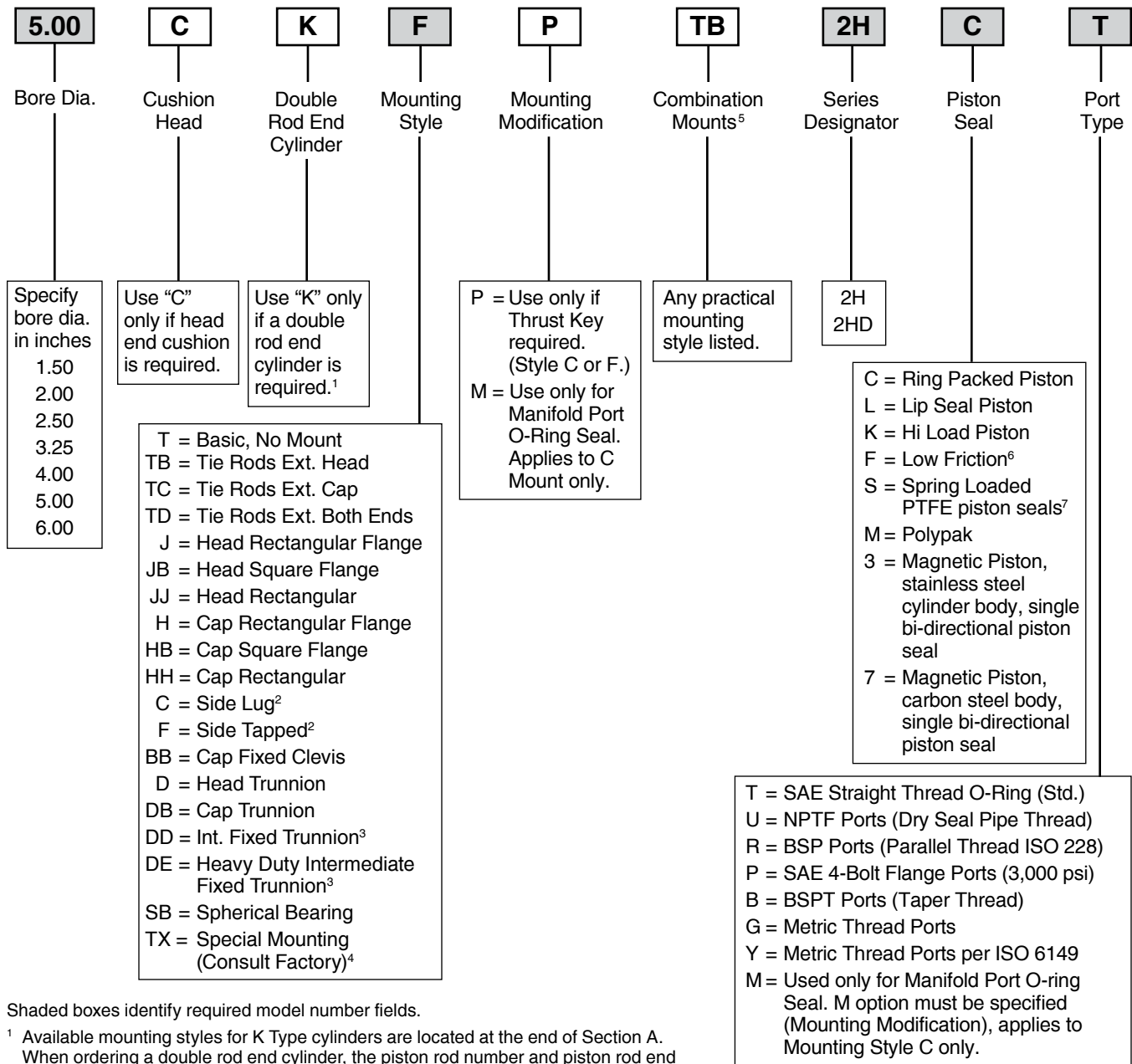

Shaded boxes identify required model number fields.

¹ Available mounting styles for K Type cylinders are located at the end of Section A. When ordering a double rod end cylinder, the piston rod number and piston rod end threads are to be specified for both rod ends.

The model number should be created as viewing the primary rod end on the left hand side.

Example: K Type Cylinder:
4.00CKTD2HLT14A28AC10.000

² Mounting Styles C and F should have a minimum stroke length equal to or greater than their bore size.

³ Specify XI dimension.

⁴ Special mounting styles that do not resemble a standard catalog offering will be designated as style TX by the factory. See page 6 for instructions to enter a mounting that resembles a standard style.

⁵ In general, the model numbers as read left to right corresponding to the cylinder as viewed from left to right with the primary end at the left. The second or subsequent mountings are mountings called out as they appear in the assembly moving away from the rod end. Except when tie rod extension mountings are part of a combination, all combinations should have a "S" (Special) in the model code and a note in the body of the order clarifying the mounting arrangement. The "P", as used to define a thrust key is not considered to be a mounting. However it is located at the primary end.

⁶ Low friction rod seals are also supplied when this option is selected.

⁷ Spring loaded PTFE piston seals are not available in 1.50, 2.00 and 2.50 bores with code 2 rod.



2H Model Code

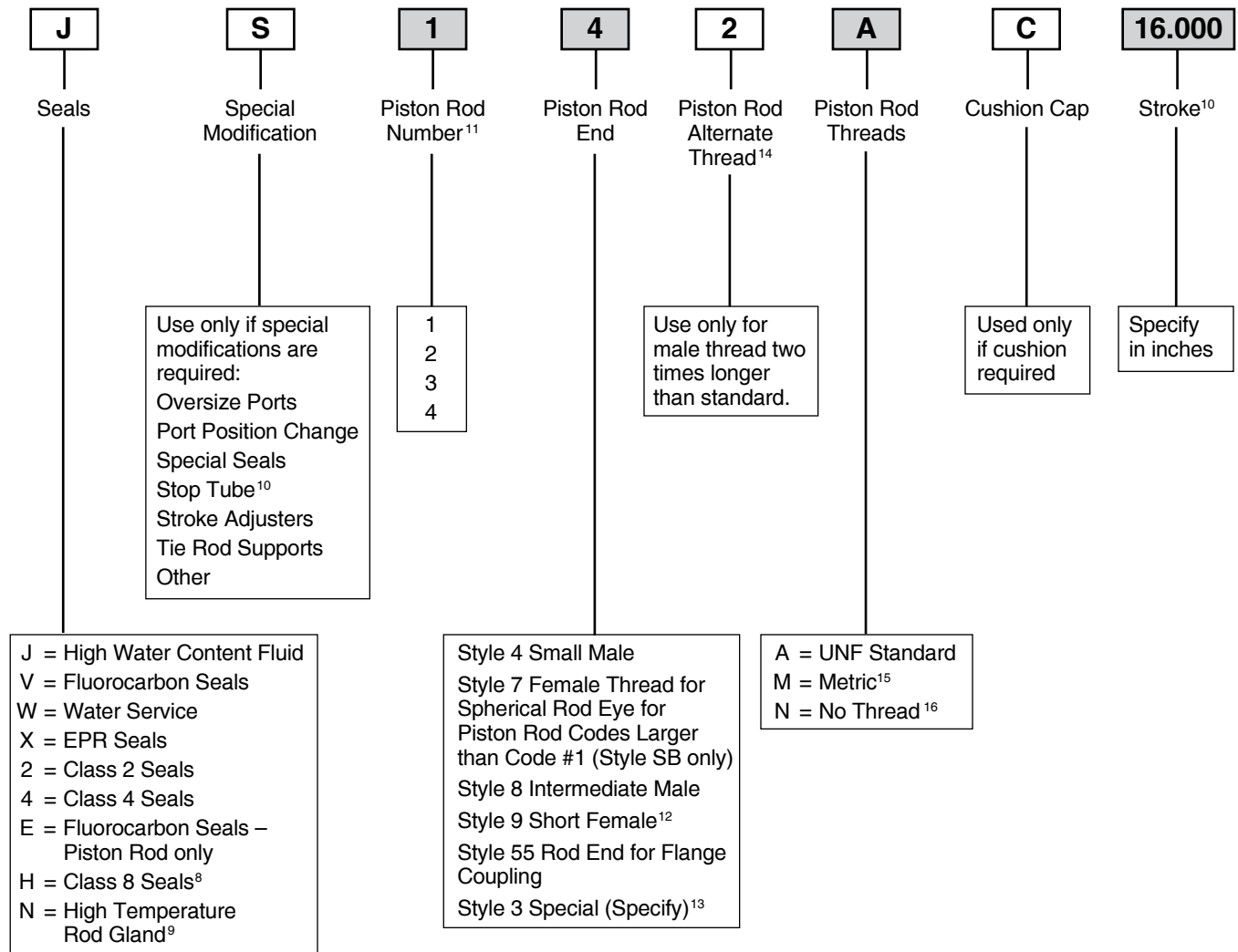

Shaded boxes identify required model number fields.

⁸ Class 8 piston seals will be cast iron rings (Piston Code C) in 1.50, 2.00 & 2.50 inch bores with code 2 rod. Spring loaded PTFE piston seals are not available in these bore and rod combinations. In all other bore and rod combinations, Piston Code S should be specified.

⁹ Energized PTFE rod seals & wiperseal. All other cylinder seals are fluorocarbon.

¹⁰ S = Stop Tube. Specify: stop tube length, net stroke and gross stroke. Gross stroke = stop tube length + net stroke. Gross stroke to be placed in the model number field.

Example:

2.000 inches long stop tube
+14.000 inches net stroke
16.000 inches gross stroke

¹¹ Refer to Rod buckling chart in Section E to assure rod number selected will not buckle under load.

¹² Style 9 stroke restrictions may apply. See Style 9 Minimum Stroke Table for details.

¹³ Provide dimensions for KK, A, W or WF. If otherwise special, furnish dimensioned sketch.

¹⁴ Available only in combination with Style 4 or Style 8.

¹⁵ See Section D for detailed information regarding standard metric rod end thread sizes.

¹⁶ Must be specified for Piston Rod End Style 55.

Style 9 Minimum Stroke Table

Bore Ø	Rod Ø	Minimum Stroke
1.50 - 4.00	All	None
5.00	2.000	None
	2.500	1.000
	3.000	1.375
	3.500	1.625
6.00	2.500	None
	3.000	1.375
	3.500	1.375
	4.000	2.000

Rod End Dimensions

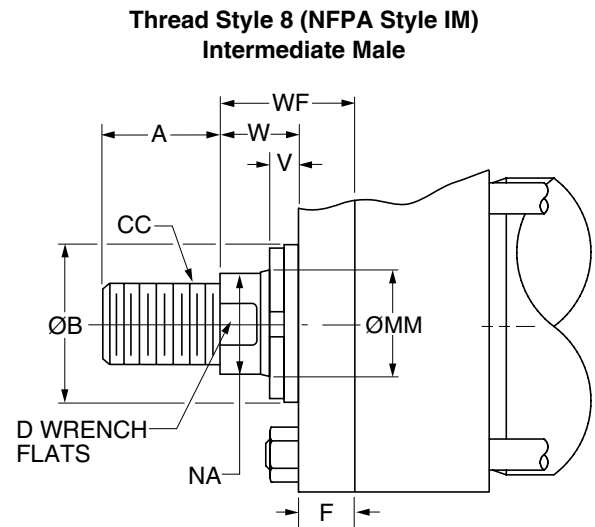
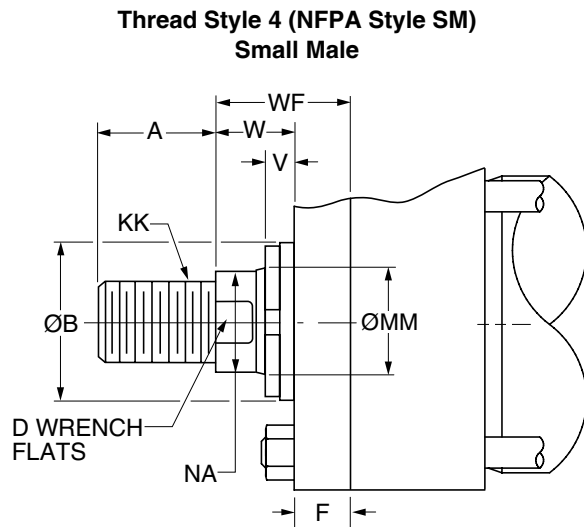

Rod End Dimensions

Bore Ø	Rod No.	MM Rod Ø	Thread		A	B Ø +0.000 -0.002	D	F	NA	V	W	WF
			Style 8 CC	Style 4 KK								
1.50	1 (Std.)	0.625	1/2-20	7/16-20	0.75	1.124	0.50	0.38	0.56	0.25	0.63	1.00
	2	1.000	7/8-14	3/4-16	1.13	1.499	0.88	0.38	0.94	0.50	1.00	1.38
2.00	1 (Std.)	1.000	7/8-14	3/4-16	1.13	1.499	0.88	0.63	0.94	0.25	0.75	1.38
	2	1.375	1 1/4-12	1-14	1.63	1.999	1.13	0.63	1.31	0.38	1.00	1.63
2.50	1 (Std.)	1.000	7/8-14	3/4-16	1.13	1.499	0.88	0.63	0.94	0.25	0.75	1.38
	2	1.750	1 1/2-12	1 1/4-12	2.00	2.374	1.50	0.63	1.69	0.50	1.25	1.88
	3	1.375	1 1/4-12	1-14	1.63	1.999	1.13	0.63	1.31	0.38	1.00	1.63
3.25	1 (Std.)	1.375	1 1/4-12	1-14	1.63	1.999	1.13	0.75	1.31	0.25	0.88	1.63
	2	2.000	1 3/4-12	1 1/2-12	2.25	2.624	1.69	0.75	1.94	0.38	1.25	2.00
	3	1.750	1 1/2-12	1 1/4-12	2.00	2.374	1.50	0.75	1.69	0.38	1.13	1.88
4.00	1 (Std.)	1.750	1 1/2-12	1 1/4-12	2.00	2.374	1.50	0.88	1.69	0.25	1.00	1.88
	2	2.500	2 1/4-12	1 7/8-12	3.00	3.124	2.06	0.88	2.38	0.38	1.38	2.25
	3	2.000	1 3/4-12	1 1/2-12	2.25	2.624	1.69	0.88	1.94	0.25	1.13	2.00
5.00	1 (Std.)	2.000	1 3/4-12	1 1/2-12	2.25	2.624	1.69	0.88	1.94	0.25	1.13	2.00
	2	3.500	3 1/4-12	2 1/2-12	3.50	4.249	3.00	0.88	3.38	0.38	1.38	2.25
	3	2.500	2 1/4-12	1 7/8-12	3.00	3.124	2.06	0.88	2.38	0.38	1.38	2.25
	4	3.000	2 3/4-12	2 1/4-12	3.50	3.749	2.63	0.88	2.88	0.38	1.38	2.25
6.00	1 (Std.)	2.500	2 1/4-12	1 7/8-12	3.00	3.124	2.06	1.00	2.38	0.25	1.25	2.25
	2	4.000	3 3/4-12	3-12	4.00	4.749	3.38	1.00	3.88	0.25	1.25	2.25
	3	3.000	2 3/4-12	2 1/4-12	3.50	3.749	2.63	1.00	2.88	0.25	1.25	2.25
	4	3.500	3 1/4-12	2 1/2-12	3.50	4.249	3.00	1.00	3.38	0.25	1.25	2.25

“Special” Thread Style 3

Special thread, extension, rod eye, blank, etc., are also available.

To order, specify “Style 3” and give desired dimensions for KK, A, W or WF.
 If otherwise special, furnish dimensioned sketch.

Rod End Dimensions

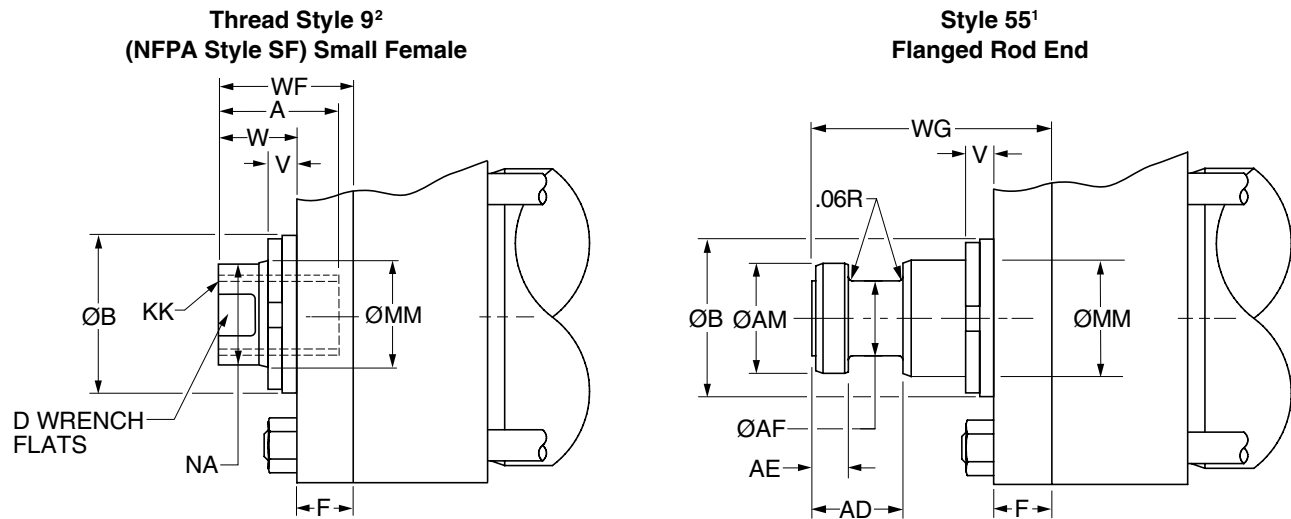

Rod End Dimensions

Bore Ø	Rod No.	MM Rod Ø	Thread	A	AD	AE +.001 -.001	AF Ø	AM Ø	B Ø +.000 -.002	D	F	NA	V	W	WF	WG
			Style 9 KK													
1.50	1 (Std.)	0.625	7/16-20	0.75	0.63	0.249	0.38	0.57	1.124	0.50	0.38	0.56	0.25	0.63	1.00	1.75
	2	1.000	3/4-16	1.13	0.94	0.374	0.69	0.95	1.499	0.88	0.38	0.94	0.50	1.00	1.38	2.38
2.00	1 (Std.)	1.000	3/4-16	1.13	0.94	0.374	0.69	0.95	1.499	0.88	0.63	0.94	0.25	0.75	1.38	2.38
	2	1.375	1-14	1.63	1.06	0.374	0.88	1.32	1.999	1.13	0.63	1.31	0.38	1.00	1.63	2.75
2.50	1 (Std.)	1.000	3/4-16	1.13	0.94	0.374	0.69	0.95	1.499	0.88	0.63	0.94	0.25	0.75	1.38	2.38
	2	1.750	1 1/4-12	2.00	1.31	0.499	1.13	1.70	2.374	1.50	0.63	1.69	0.50	1.25	1.88	3.13
	3	1.375	1-14	1.63	1.06	0.374	0.88	1.32	1.999	1.13	0.63	1.31	0.38	1.00	1.63	2.75
3.25	1 (Std.)	1.375	1-14	1.63	1.06	0.374	0.88	1.32	1.999	1.13	0.75	1.31	0.25	0.88	1.63	2.75
	2	2.000	1 1/2-12	2.25	1.69	0.624	1.38	1.95	2.624	1.69	0.75	1.94	0.38	1.25	2.00	3.75
	3	1.750	1 1/4-12	2.00	1.31	0.499	1.13	1.70	2.374	1.50	0.75	1.69	0.38	1.13	1.88	3.13
4.00	1 (Std.)	1.750	1 1/4-12	2.00	1.31	0.499	1.13	1.70	2.374	1.50	0.88	1.69	0.25	1.00	1.88	3.13
	2	2.500	1 7/8-12	3.00	1.94	0.749	1.75	2.45	3.124	2.06	0.88	2.38	0.38	1.38	2.25	4.50
	3	2.000	1 1/2-12	2.25	1.69	0.624	1.38	1.95	2.624	1.69	0.88	1.94	0.25	1.13	2.00	3.75
5.00	1 (Std.)	2.000	1 1/2-12	2.25	1.69	0.624	1.38	1.95	2.624	1.69	0.88	1.94	0.25	1.13	2.00	3.75
	2	3.500	2 1/2-12	3.50	2.69	0.999	2.50	3.45	4.249	3.00	0.88	3.38	0.38	1.38	2.25	5.63
	3	2.500	1 7/8-12	3.00	1.94	0.749	1.75	2.45	3.124	2.06	0.88	2.38	0.38	1.38	2.25	4.50
	4	3.000	2 1/4-12	3.50	2.44	0.874	2.25	2.95	3.749	2.63	0.88	2.88	0.38	1.38	2.25	4.88
6.00	1 (Std.)	2.500	1 7/8-12	3.00	1.94	0.749	1.75	2.45	3.124	2.06	1.00	2.38	0.25	1.25	2.25	4.50
	2	4.000	3-12	4.00	2.69	0.999	3.00	3.95	4.749	3.38	1.00	3.88	0.25	1.25	2.25	5.75
	3	3.000	2 1/4-12	3.50	2.44	0.874	2.25	2.95	3.749	2.63	1.00	2.88	0.25	1.25	2.25	4.88
	4	3.500	2 1/2-12	3.50	2.69	0.999	2.50	3.45	4.249	3.00	1.00	3.38	0.25	1.25	2.25	5.63

“Special” Thread Style 3

Special thread, extension, rod eye, blank, etc., are also available.

To order, specify “Style 3” and give desired dimensions for KK, A, W or WF. If otherwise special, furnish dimensioned sketch.

¹ For special WG dimension, specify “Style 3” and give desired dimension for WG. For other changes, place “S” in the model code, and describe rod end with dimensioned sketch.

² Style 9 stroke restrictions may apply. See Style 9 Minimum Stroke Table on How to Order page for details.



Tie Rods Extended Both Ends Mounting
Style TD
 (NFFA Style MX1)

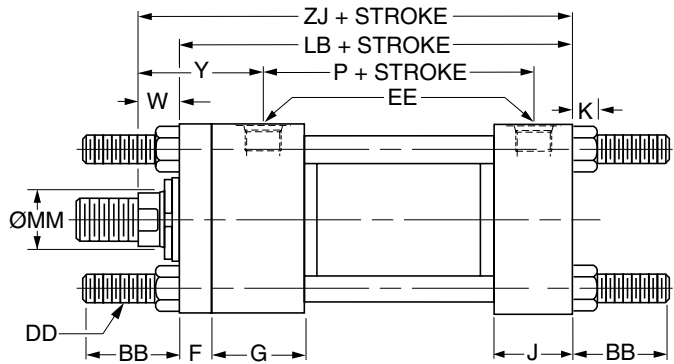
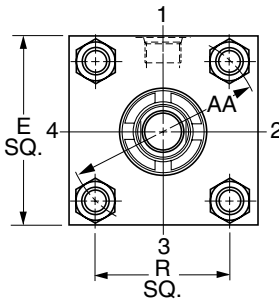
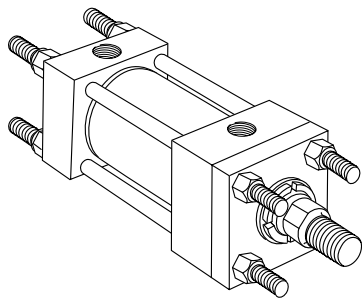

Style TD – Dimensional and Mounting Data

Bore Ø	Rod No.	MM Rod Ø	AA	BB	DD	E	EE		F	G	J	K	R	W	Y	Add Stroke		
							NPTF ¹	SAE ²								LB	P	ZJ
1.50	1 (std.)	0.625	2.31	1.38	3/8-24	2.50	1/2	10	0.38	1.75	1.50	0.38	1.63	0.63	2.00	5.00	2.88	5.63
	2	1.000	2.31	1.38	3/8-24	2.50	1/2	10	0.38	1.75	1.50	0.38	1.63	1.00	2.38	5.00	2.88	6.00
2.00	1 (std.)	1.000	2.90	1.81	1/2-20	3.00	1/2	10	0.63	1.75	1.50	0.44	2.05	0.75	2.38	5.25	2.88	6.00
	2	1.375	2.90	1.81	1/2-20	3.00	1/2	10	0.63	1.75	1.50	0.44	2.05	1.00	2.63	5.25	2.88	6.25
2.50	1 (std.)	1.000	3.61	1.81	1/2-20	3.50	1/2	10	0.63	1.75	1.50	0.44	2.55	0.75	2.38	5.38	3.00	6.13
	2	1.750	3.61	1.81	1/2-20	3.50	1/2	10	0.63	1.75	1.50	0.44	2.55	1.25	2.88	5.38	3.00	6.63
	3	1.375	3.61	1.81	1/2-20	3.50	1/2	10	0.63	1.75	1.50	0.44	2.55	1.00	2.63	5.38	3.00	6.38
3.25	1 (std.)	1.375	4.60	2.31	5/8-18	4.50	3/4	12	0.75	2.00	1.75	0.56	3.25	0.88	2.75	6.25	3.50	7.13
	2	2.000	4.60	2.31	5/8-18	4.50	3/4	12	0.75	2.00	1.75	0.56	3.25	1.25	3.13	6.25	3.50	7.50
	3	1.750	4.60	2.31	5/8-18	4.50	3/4	12	0.75	2.00	1.75	0.56	3.25	1.13	3.00	6.25	3.50	7.38
4.00	1 (std.)	1.750	5.40	2.31	5/8-18	5.00	3/4	12	0.88	2.00	1.75	0.56	3.82	1.00	3.00	6.63	3.75	7.63
	2	2.500	5.40	2.31	5/8-18	5.00	3/4	12	0.88	2.00	1.75	0.56	3.82	1.38	3.38	6.63	3.75	8.00
	3	2.000	5.40	2.31	5/8-18	5.00	3/4	12	0.88	2.00	1.75	0.56	3.82	1.13	3.13	6.63	3.75	7.75
5.00	1 (std.)	2.000	7.00	3.19	7/8-14	6.50	3/4	12	0.88	2.00	1.75	0.81	4.95	1.13	3.13	7.13	4.25	8.25
	2	3.500	7.00	3.19	7/8-14	6.50	3/4	12	0.88	2.00	1.75	0.81	4.95	1.38	3.38	7.13	4.25	8.50
	3	2.500	7.00	3.19	7/8-14	6.50	3/4	12	0.88	2.00	1.75	0.81	4.95	1.38	3.38	7.13	4.25	8.50
	4	3.000	7.00	3.19	7/8-14	6.50	3/4	12	0.88	2.00	1.75	0.81	4.95	1.38	3.38	7.13	4.25	8.50
6.00	1 (std.)	2.500	8.10	3.63	1-14	7.50	1	16	1.00	2.25	2.25	0.88	5.73	1.25	3.50	8.38	4.88	9.63
	2	4.000	8.10	3.63	1-14	7.50	1	16	1.00	2.25	2.25	0.88	5.73	1.25	3.50	8.38	4.88	9.63
	3	3.000	8.10	3.63	1-14	7.50	1	16	1.00	2.25	2.25	0.88	5.73	1.25	3.50	8.38	4.88	9.63
	4	3.500	8.10	3.63	1-14	7.50	1	16	1.00	2.25	2.25	0.88	5.73	1.25	3.50	8.38	4.88	9.63

¹NPTF ports are available at no extra charge.

²SAE straight thread ports are standard and are indicated by port number.

Style T

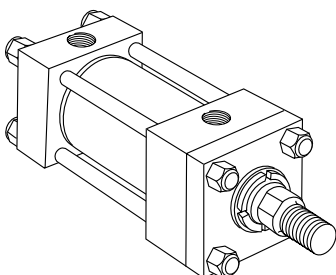

Style TB

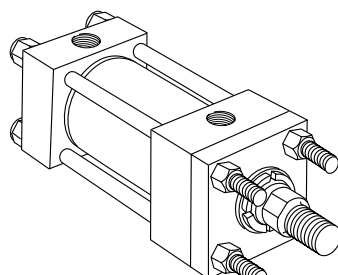

Style TC

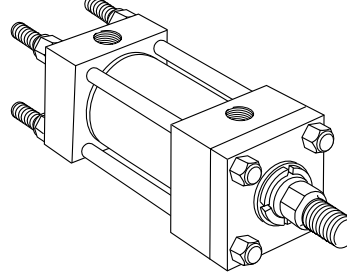

Dimensions for T, TB and TC Mount may be obtained from the above dimensional table.

Mounting Information – 1.50" to 6.00" Bore Series 2H

Head Rectangular Flange Mounting

Style J
(NFPA Style MF1)

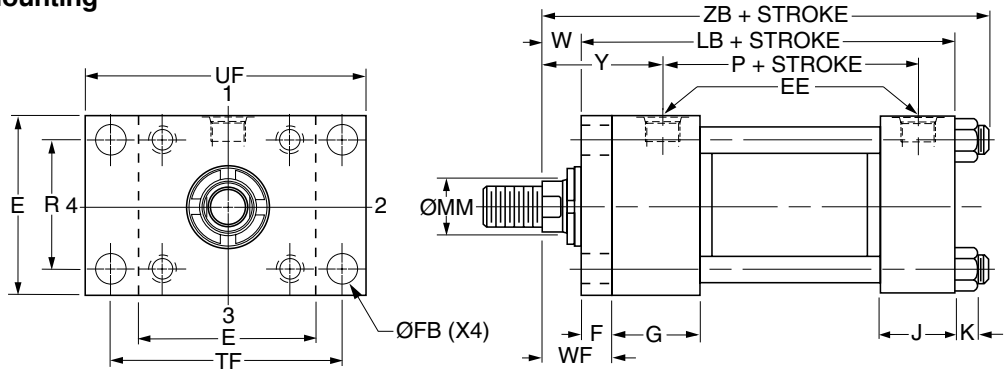
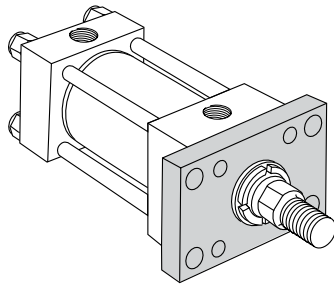

Style J – Dimensional and Mounting Data

Bore Ø	E	EE		F	FB Ø	G	J	K	R	TF	UF	Add Stroke	
		NPTF ¹	SAE ²									LB	P
1.50	2.50	1/2	10	0.38	0.44	1.75	1.50	0.38	1.63	3.44	4.25	5.00	2.88
2.00	3.00	1/2	10	0.63	0.56	1.75	1.50	0.44	2.05	4.13	5.13	5.25	2.88
2.50	3.50	1/2	10	0.63	0.56	1.75	1.50	0.44	2.55	4.63	5.63	5.38	3.00
3.25	4.50	3/4	12	0.75	0.69	2.00	1.75	0.56	3.25	5.88	7.13	6.25	3.50
4.00	5.00	3/4	12	0.88	0.69	2.00	1.75	0.56	3.82	6.38	7.63	6.63	3.75
5.00	6.50	3/4	12	0.88	0.94	2.00	1.75	0.81	4.95	8.19	9.75	7.13	4.25
6.00	7.50	1	16	1.00	1.06	2.25	2.25	0.88	5.73	9.44	11.25	8.38	4.88

¹NPTF ports are available at no extra charge.

²SAE straight thread ports are standard and are indicated by port number.

Style J – Dimensional and Mounting Data

Bore Ø	Rod No.	MM Rod Ø	W	WF	Y	Add Stroke
						ZB Max.
1.50	1 (std.)	0.625	0.63	1.00	2.00	6.25
	2	1.000	1.00	1.38	2.38	6.63
2.00	1 (std.)	1.000	0.75	1.38	2.38	6.69
	2	1.375	1.00	1.63	2.63	6.94
2.50	1 (std.)	1.000	0.75	1.38	2.38	6.81
	2	1.750	1.25	1.88	2.88	7.31
	3	1.375	1.00	1.63	2.63	7.06
3.25	1 (std.)	1.375	0.88	1.63	2.75	7.94
	2	2.000	1.25	2.00	3.13	8.31
	3	1.750	1.13	1.88	3.00	8.19
4.00	1 (std.)	1.750	1.00	1.88	3.00	8.50
	2	2.500	1.38	2.25	3.38	8.88
	3	2.000	1.13	2.00	3.13	8.63
5.00	1 (std.)	2.000	1.13	2.00	3.13	9.38
	2	3.500	1.38	2.25	3.38	9.63
	3	2.500	1.38	2.25	3.38	9.63
	4	3.000	1.38	2.25	3.38	9.63
6.00	1 (std.)	2.500	1.25	2.25	3.50	10.81
	2	4.000	1.25	2.25	3.50	10.81
	3	3.000	1.25	2.25	3.50	10.81
	4	3.500	1.25	2.25	3.50	10.81

Style J – Maximum Operating Pressure / 2H

Bore Ø	Maximum psi Push ³			
	Rod Code			
	1	2	3	4
1.50	1500	1000	-	-
2.00	2000	1200	-	-
2.50	2000	1100	1500	-
3.25	1800	1300	1400	-
4.00	1800	1300	1700	-
5.00	1300	800	1200	1000
6.00	1200	800	1000	900

Style J – Maximum Operating Pressure / 2HD

Bore Ø	Maximum psi Push ³			
	Rod Code			
	1	2	3	4
1.50	1400	1000	-	-
2.00	2000	1200	-	-
2.50	700	1000	700	-
3.25	800	600	800	-
4.00	1000	700	1000	-
5.00	850	800	850	450
6.00	650	400	650	400

³Maximum Pressure Rating – Push Application.



Mounting Information – 1.50" to 6.00" Bore Series 2H

Head Square Flange Mounting
Style JB
(NFPA Style MF5)

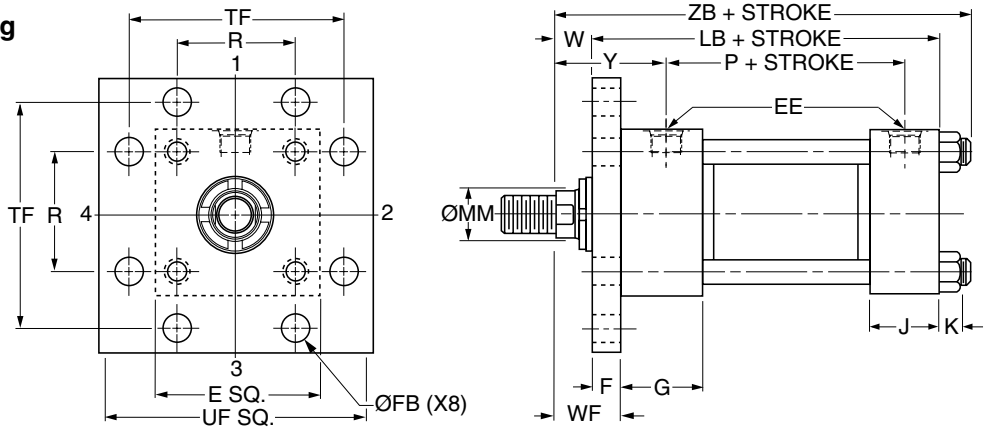
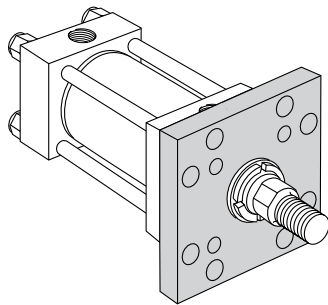

Style JB – Dimensional and Mounting Data

Bore Ø	E	EE		F	FB Ø	G	J	K	R	TF	UF	Add Stroke	
		NPTF ¹	SAE ²									LB	P
1.50	2.50	1/2	10	0.38	0.44	1.75	1.50	0.38	1.63	3.44	4.25	5.00	2.88
2.00	3.00	1/2	10	0.63	0.56	1.75	1.50	0.44	2.05	4.13	5.13	5.25	2.88
2.50	3.50	1/2	10	0.63	0.56	1.75	1.50	0.44	2.55	4.63	5.63	5.38	3.00
3.25	4.50	3/4	12	0.75	0.69	2.00	1.75	0.56	3.25	5.88	7.13	6.25	3.50
4.00	5.00	3/4	12	0.88	0.69	2.00	1.75	0.56	3.82	6.38	7.63	6.63	3.75
5.00	6.50	3/4	12	0.88	0.94	2.00	1.75	0.81	4.95	8.19	9.75	7.13	4.25
6.00	7.50	1	16	1.00	1.06	2.25	2.25	0.88	5.73	9.44	11.25	8.38	4.88

¹NPTF ports are available at no extra charge.

²SAE straight thread ports are standard and are indicated by port number.

Style JB – Dimensional and Mounting Data

Bore Ø	Rod No.	MM Rod Ø	W	WF	Y	Add Stroke
						ZB Max.
1.50	1 (std.)	0.625	0.63	1.00	2.00	6.25
	2	1.000	1.00	1.38	2.38	6.63
2.00	1 (std.)	1.000	0.75	1.38	2.38	6.69
	2	1.375	1.00	1.63	2.63	6.94
2.50	1 (std.)	1.000	0.75	1.38	2.38	6.81
	2	1.750	1.25	1.88	2.88	7.31
	3	1.375	1.00	1.63	2.63	7.06
3.25	1 (std.)	1.375	0.88	1.63	2.75	7.94
	2	2.000	1.25	2.00	3.13	8.31
	3	1.750	1.13	1.88	3.00	8.19
4.00	1 (std.)	1.750	1.00	1.88	3.00	8.50
	2	2.500	1.38	2.25	3.38	8.88
	3	2.000	1.13	2.00	3.13	8.63
5.00	1 (std.)	2.000	1.13	2.00	3.13	9.38
	2	3.500	1.38	2.25	3.38	9.63
	3	2.500	1.38	2.25	3.38	9.63
	4	3.000	1.38	2.25	3.38	9.63
6.00	1 (std.)	2.500	1.25	2.25	3.50	10.81
	2	4.000	1.25	2.25	3.50	10.81
	3	3.000	1.25	2.25	3.50	10.81
	4	3.500	1.25	2.25	3.50	10.81

Style JB – Maximum Operating Pressure / 2H

Bore Ø	Maximum psi Push ³			
	Rod Code			
	1	2	3	4
1.50	3000	3000	-	-
2.00	3000	3000	-	-
2.50	3000	3000	3000	-
3.25	3000	3000	3000	-
4.00	3000	3000	3000	-
5.00	3000	3000	3000	3000
6.00	3000	2700	3000	2700

Style JB – Maximum Operating Pressure / 2HD

Bore Ø	Maximum psi Push ³			
	Rod Code			
	1	2	3	4
1.50	3000	3000	-	-
2.00	3000	3000	-	-
2.50	3000	3000	3000	-
3.25	3000	3000	3000	-
4.00	3000	3000	3000	-
5.00	2500	2300	2500	1800
6.00	2000	1600	2000	1600

³Maximum Pressure Rating – Push Application.

Mounting Information – 1.50" to 6.00" Bore Series 2H

Head Rectangular Mounting
Style JJ
 (NFPA Style ME5)

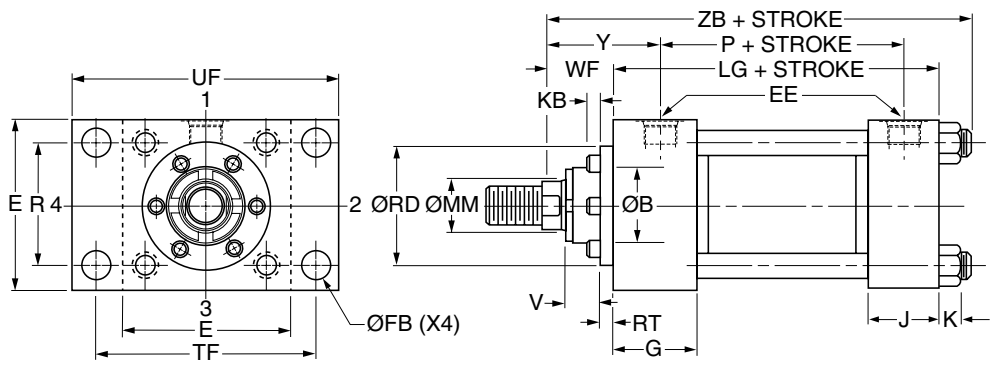
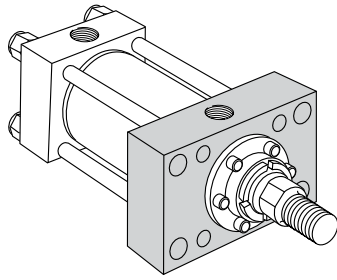

Style JJ – Dimensional and Mounting Data

Bore Ø	E	EE		FB Ø	G	J	K	R	TF	UF	Add Stroke	
		NPTF ¹	SAE ²								LG	P
1.50	2.50	1/2	10	0.44	1.75	1.50	0.38	1.63	3.44	4.25	4.63	2.88
2.00	3.00	1/2	10	0.56	1.75	1.50	0.44	2.05	4.13	5.13	4.63	2.88
2.50	3.50	1/2	10	0.56	1.75	1.50	0.44	2.55	4.63	5.63	4.75	3.00
3.25	4.50	3/4	12	0.69	2.00	1.75	0.56	3.25	5.88	7.13	5.50	3.50
4.00	5.00	3/4	12	0.69	2.00	1.75	0.56	3.82	6.38	7.63	5.75	3.75
5.00	6.50	3/4	12	0.94	2.00	1.75	0.81	4.95	8.19	9.75	6.25	4.25
6.00	7.50	1	16	1.06	2.25	2.25	0.88	5.73	9.44	11.25	7.38	4.88

¹NPTF ports are available at no extra charge.

²SAE straight thread ports are standard and are indicated by port number.

Style JJ – Dimensional and Mounting Data

Bore Ø	Rod No.	MM Rod Ø	B Ø +.000 -0.002	KB	RD Ø	RT	V	WF	Y	Add Stroke
										ZB Max
1.50	1 (std.)	0.625	1.124	-	2.13	0.38	0.25	1.00	2.00	6.25
	2	1.000	1.499	-	2.50	0.38	0.50	1.38	2.38	6.63
2.00	1 (std.)	1.000	1.499	-	2.50	0.38	0.50	1.38	2.38	6.69
	2	1.375	1.999	.25	3.00	0.38	0.63	1.63	2.63	6.94
2.50	1 (std.)	1.000	1.499	-	2.50	0.38	0.50	1.38	2.38	6.81
	2	1.750	2.374	.25	3.50	0.38	0.75	1.88	2.88	7.31
	3	1.375	1.999	.25	3.00	0.38	0.63	1.63	2.63	7.06
3.25	1 (std.)	1.375	1.999	.25	3.00	0.38	0.63	1.63	2.75	7.94
	2	2.000	2.624	.13	4.00	0.63	0.50	2.00	3.13	8.31
	3	1.750	2.374	.25	3.50	0.38	0.75	1.88	3.00	8.19
4.00	1 (std.)	1.750	2.374	.25	3.50	0.38	0.75	1.88	3.00	8.50
	2	2.500	3.124	.25	4.50	0.63	0.63	2.25	3.38	8.88
	3	2.000	2.624	.13	4.00	0.63	0.50	2.00	3.13	8.63
5.00	1 (std.)	2.000	2.624	.13	4.00	0.63	0.50	2.00	3.13	9.38
	2	3.500	4.249	.25	5.75	0.63	0.63	2.25	3.38	9.63
	3	2.500	3.124	.25	4.50	0.63	0.63	2.25	3.38	9.63
	4	3.000	3.749	.25	5.25	0.63	0.63	2.25	3.38	9.63
6.00	1 (std.)	2.500	3.124	.25	4.50	0.63	0.63	2.25	3.50	10.81
	2	4.000	4.749	.25	6.50	0.75	0.50	2.25	3.50	10.81
	3	3.000	3.749	.25	5.25	0.63	0.63	2.25	3.50	10.81
	4	3.500	4.249	.25	5.75	0.63	0.63	2.25	3.50	10.81



Mounting Information – 1.50" to 6.00" Bore Series 2H

Cap Rectangular Flange Mounting

Style H
(NFPA Style MF2)

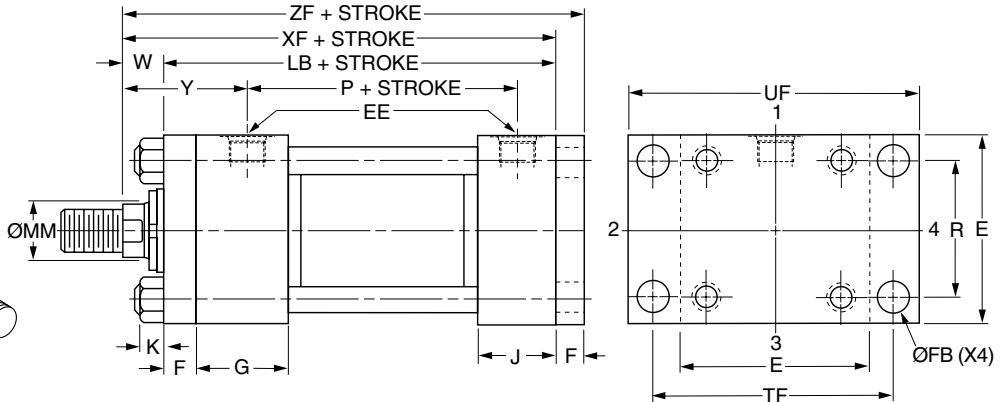
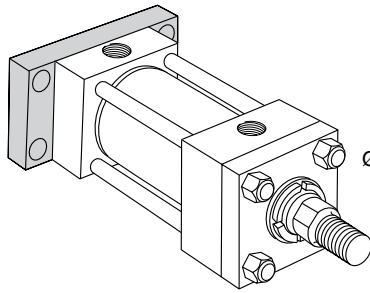

Style H – Dimensional and Mounting Data

Bore Ø	E	EE		F	FB Ø	G	J	K	R	TF	UF	Add Stroke	
		NPTF ¹	SAE ²									LB	P
1.50	2.50	1/2	10	0.38	0.44	1.75	1.50	0.38	1.63	3.44	4.25	5.00	2.88
2.00	3.00	1/2	10	0.63	0.56	1.75	1.50	0.44	2.05	4.13	5.13	5.25	2.88
2.50	3.50	1/2	10	0.63	0.56	1.75	1.50	0.44	2.55	4.63	5.63	5.38	3.00
3.25	4.50	3/4	12	0.75	0.69	2.00	1.75	0.56	3.25	5.88	7.13	6.25	3.50
4.00	5.00	3/4	12	0.88	0.69	2.00	1.75	0.56	3.82	6.38	7.63	6.63	3.75
5.00	6.50	3/4	12	0.88	0.94	2.00	1.75	0.81	4.95	8.19	9.75	7.13	4.25
6.00	7.50	1	16	1.00	1.06	2.25	2.25	0.88	5.73	9.44	11.25	8.38	4.88

¹NPTF ports are available at no extra charge.

²SAE straight thread ports are standard and are indicated by port number.

Style H – Dimensional and Mounting Data

Bore Ø	Rod No.	MM Rod Ø	W	Y	Add Stroke	
					XF	ZF
1.50	1 (std.)	0.625	0.63	2.00	5.63	6.00
	2	1.000	1.00	2.38	6.00	6.38
2.00	1 (std.)	1.000	0.75	2.38	6.00	6.63
	2	1.375	1.00	2.63	6.25	6.88
2.50	1 (std.)	1.000	0.75	2.38	6.13	6.75
	2	1.750	1.25	2.88	6.63	7.25
	3	1.375	1.00	2.63	6.38	7.00
3.25	1 (std.)	1.375	0.88	2.75	7.13	7.88
	2	2.000	1.25	3.13	7.50	8.25
	3	1.750	1.13	3.00	7.38	8.13
4.00	1 (std.)	1.750	1.00	3.00	7.63	8.50
	2	2.500	1.38	3.38	8.00	8.88
	3	2.000	1.13	3.13	7.75	8.63
5.00	1 (std.)	2.000	1.13	3.13	8.25	9.13
	2	3.500	1.38	3.38	8.50	9.38
	3	2.500	1.38	3.38	8.50	9.38
	4	3.000	1.38	3.38	8.50	9.38
6.00	1 (std.)	2.500	1.25	3.50	9.63	10.63
	2	4.000	1.25	3.50	9.63	10.63
	3	3.000	1.25	3.50	9.63	10.63
	4	3.500	1.25	3.50	9.63	10.63

Style H – Maximum Operating Pressure / 2H & 2HD

Bore Ø	Maximum psi Pull ³			
	Rod Code			
	1	2	3	4
1.50	2500	3000	-	-
2.00	3000	3000	-	-
2.50	3000	3000	3000	-
3.25	3000	3000	3000	-
4.00	3000	3000	3000	-
5.00	2000	3000	2000	2500
6.00	1800	2500	2000	2000

³Maximum pressure rating — pull application.

Mounting Information – 1.50" to 6.00" Bore Series 2H

Cap Square Flange Mounting
Style HB
(NFPA Style MF6)

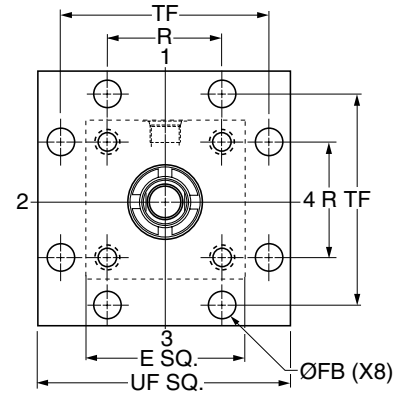
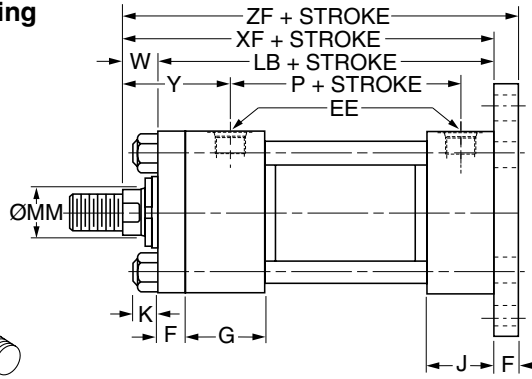
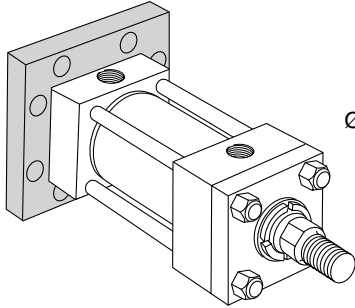

Style HB – Dimensional and Mounting Data

Bore Ø	E	EE		F	FB Ø	G	J	K	R	TF	UF	Add Stroke	
		NPTF ¹	SAE ²									LB	P
1.50	2.50	1/2	10	0.38	0.44	1.75	1.50	0.38	1.63	3.44	4.25	5.00	2.88
2.00	3.00	1/2	10	0.63	0.56	1.75	1.50	0.44	2.05	4.13	5.13	5.25	2.88
2.50	3.50	1/2	10	0.63	0.56	1.75	1.50	0.44	2.55	4.63	5.63	5.38	3.00
3.25	4.50	3/4	12	0.75	0.69	2.00	1.75	0.56	3.25	5.88	7.13	6.25	3.50
4.00	5.00	3/4	12	0.88	0.69	2.00	1.75	0.56	3.82	6.38	7.63	6.63	3.75
5.00	6.50	3/4	12	0.88	0.94	2.00	1.75	0.81	4.95	8.19	9.75	7.13	4.25
6.00	7.50	1	16	1.00	1.06	2.25	2.25	0.88	5.73	9.44	11.25	8.38	4.88

¹NPTF ports are available at no extra charge.

²SAE straight thread ports are standard and are indicated by port number.

Style HB – Dimensional and Mounting Data

Bore Ø	Rod No.	MM Rod Ø	W	Y	Add Stroke	
					XF	ZF
1.50	1 (std.)	0.625	0.63	2.00	5.63	6.00
	2	1.000	1.00	2.38	6.00	6.38
2.00	1 (std.)	1.000	0.75	2.38	6.00	6.63
	2	1.375	1.00	2.63	6.25	6.88
2.50	1 (std.)	1.000	0.75	2.38	6.13	6.75
	2	1.750	1.25	2.88	6.63	7.25
	3	1.375	1.00	2.63	6.38	7.00
3.25	1 (std.)	1.375	0.88	2.75	7.13	7.88
	2	2.000	1.25	3.13	7.50	8.25
	3	1.750	1.13	3.00	7.38	8.13
4.00	1 (std.)	1.750	1.00	3.00	7.63	8.50
	2	2.500	1.38	3.38	8.00	8.88
	3	2.000	1.13	3.13	7.75	8.63
5.00	1 (std.)	2.000	1.13	3.13	8.25	9.13
	2	3.500	1.38	3.38	8.50	9.38
	3	2.500	1.38	3.38	8.50	9.38
	4	3.000	1.38	3.38	8.50	9.38
6.00	1 (std.)	2.500	1.25	3.50	9.63	10.63
	2	4.000	1.25	3.50	9.63	10.63
	3	3.000	1.25	3.50	9.63	10.63
	4	3.500	1.25	3.50	9.63	10.63



Mounting Information – 1.50" to 6.00" Bore Series 2H

Cap Rectangular Flange Mounting
 Style HH
 (NFPA Style ME6)

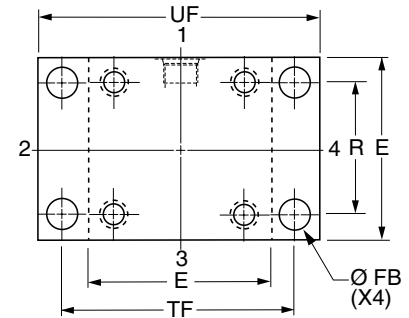
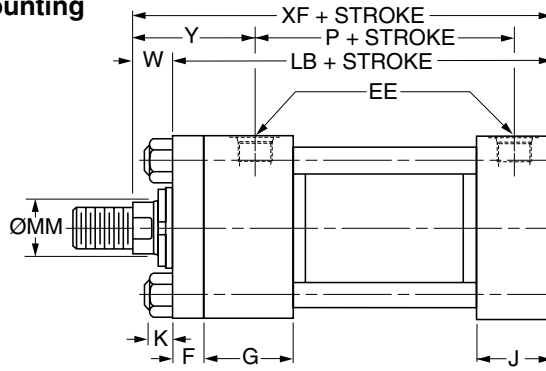
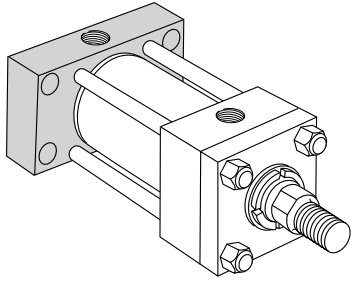

Style HH – Dimensional and Mounting Data

Bore Ø	E	EE		F	FB Ø	G	J	K	R	TF	UF	Add Stroke	
		NPTF ¹	SAE ²									LB	P
1.50	2.50	1/2	10	0.38	0.44	1.75	1.50	0.38	1.63	3.44	4.25	5.00	2.88
2.00	3.00	1/2	10	0.63	0.56	1.75	1.50	0.44	2.05	4.13	5.13	5.25	2.88
2.50	3.50	1/2	10	0.63	0.56	1.75	1.50	0.44	2.55	4.63	5.63	5.38	3.00
3.25	4.50	3/4	12	0.75	0.69	2.00	1.75	0.56	3.25	5.88	7.13	6.25	3.50
4.00	5.00	3/4	12	0.88	0.69	2.00	1.75	0.56	3.82	6.38	7.63	6.63	3.75
5.00	6.50	3/4	12	0.88	0.94	2.00	1.75	0.81	4.95	8.19	9.75	7.13	4.25
6.00	7.50	1	16	1.00	1.06	2.25	2.25	0.88	5.73	9.44	11.25	8.38	4.88

¹NPTF ports are available at no extra charge.

²SAE straight thread ports are standard and are indicated by port number.

Style HH – Dimensional and Mounting Data

Bore Ø	Rod No.	MM Rod Ø	W	Y	Add Stroke
					XF
1.50	1 (std.)	0.625	0.63	2.00	5.63
	2	1.000	1.00	2.38	6.00
2.00	1 (std.)	1.000	0.75	2.38	6.00
	2	1.375	1.00	2.63	6.25
2.50	1 (std.)	1.000	0.75	2.38	6.13
	2	1.750	1.25	2.88	6.63
	3	1.375	1.00	2.63	6.38
3.25	1 (std.)	1.375	0.88	2.75	7.13
	2	2.000	1.25	3.13	7.50
	3	1.750	1.13	3.00	7.38
4.00	1 (std.)	1.750	1.00	3.00	7.63
	2	2.500	1.38	3.38	8.00
	3	2.000	1.13	3.13	7.75
5.00	1 (std.)	2.000	1.13	3.13	8.25
	2	3.500	1.38	3.38	8.50
	3	2.500	1.38	3.38	8.50
	4	3.000	1.38	3.38	8.50
6.00	1 (std.)	2.500	1.25	3.50	9.63
	2	4.000	1.25	3.50	9.63
	3	3.000	1.25	3.50	9.63
	4	3.500	1.25	3.50	9.63

Mounting Information – 1.50" to 6.00" Bore Series 2H

**Side Lug Mounting
Style C
(NFPA Style MS2)**

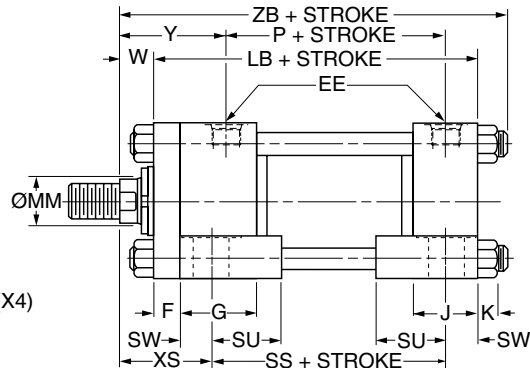
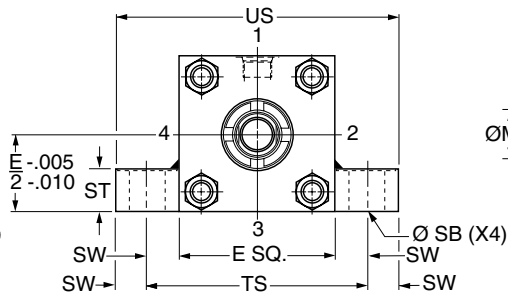
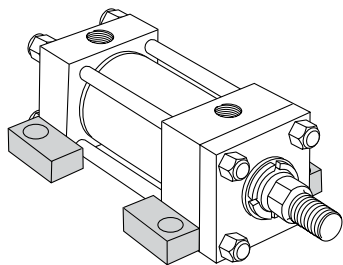

Style C – Dimensional and Mounting Data

Bore Ø	E	EE		F	G	J	K	SB ³ Ø	ST	SU	SW	TS	US	Add Stroke		
		NPTF ¹	SAE ²											LB	P	SS
1.50	2.50	1/2	10	0.38	1.75	1.50	0.38	0.44	0.50	0.94	0.38	3.25	4.00	5.00	2.88	3.88
2.00	3.00	1/2	10	0.63	1.75	1.50	0.44	0.56	0.75	1.25	0.50	4.00	5.00	5.25	2.88	3.63
2.50	3.50	1/2	10	0.63	1.75	1.50	0.44	0.81	1.00	1.56	0.69	4.88	6.25	5.38	3.00	3.38
3.25	4.50	3/4	12	0.75	2.00	1.75	0.56	0.81	1.00	1.56	0.69	5.88	7.25	6.25	3.50	4.13
4.00	5.00	3/4	12	0.88	2.00	1.75	0.56	1.06	1.25	2.00	0.88	6.75	8.50	6.63	3.75	4.00
5.00	6.50	3/4	12	0.88	2.00	1.75	0.81	1.06	1.25	2.00	0.88	8.25	10.00	7.13	4.25	4.50
6.00	7.50	1	16	1.00	2.25	2.25	0.88	1.31	1.50	2.50	1.13	9.75	12.00	8.38	4.88	5.13

¹NPTF ports are available at no extra charge.

²SAE straight thread ports are standard and are indicated by port number.

³Upper surface spot faced for socket head screws.

Style C – Dimensional and Mounting Data

Bore Ø	Rod No.	MM Rod Ø	W	XS	Y	Add Stroke
						ZB Max.
1.50	1 (std.)	0.625	0.63	1.38	2.00	6.25
	2	1.000	1.00	1.75	2.38	6.63
2.00	1 (std.)	1.000	0.75	1.88	2.38	6.69
	2	1.375	1.00	2.13	2.63	6.94
2.50	1 (std.)	1.000	0.75	2.06	2.38	6.81
	2	1.750	1.25	2.56	2.88	7.31
	3	1.375	1.00	2.31	2.63	7.06
3.25	1 (std.)	1.375	0.88	2.31	2.75	7.94
	2	2.000	1.25	2.69	3.13	8.31
	3	1.750	1.13	2.56	3.00	8.19
4.00	1 (std.)	1.750	1.00	2.75	3.00	8.50
	2	2.500	1.38	3.13	3.38	8.88
	3	2.000	1.13	2.88	3.13	8.63
5.00	1 (std.)	2.000	1.13	2.88	3.13	9.38
	2	3.500	1.38	3.13	3.38	9.63
	3	2.500	1.38	3.13	3.38	9.63
	4	3.000	1.38	3.13	3.38	9.63
6.00	1 (std.)	2.500	1.25	3.38	3.50	10.81
	2	4.000	1.25	3.38	3.50	10.81
	3	3.000	1.25	3.38	3.50	10.81
	4	3.500	1.25	3.38	3.50	10.81



Mounting Information – 1.50" to 6.00" Bore Series 2H

**Side Tapped Mounting
Style F
(NFPA Style MS4)**

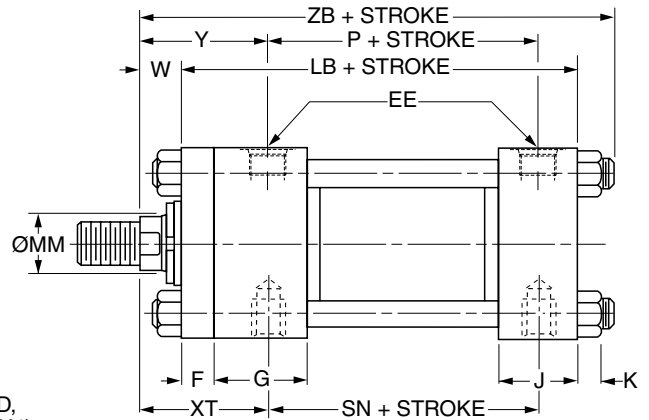
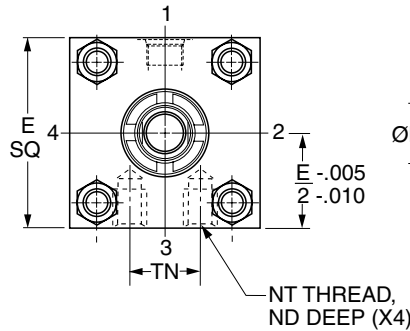
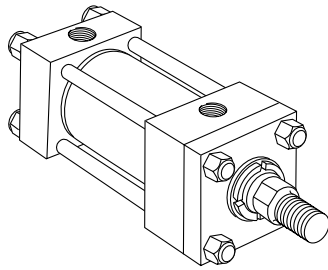

Style F – Dimensional and Mounting Data

Bore Ø	E	EE		F	G	J	K	ND	NT	TN	Add Stroke		
		NPTF ¹	SAE ²								LB	P	SN
1.50	2.50	1/2	10	0.38	1.75	1.50	0.38	0.38	3/8-16	0.75	5.00	2.88	2.88
2.00	3.00	1/2	10	0.63	1.75	1.50	0.44	0.44	1/2-13	0.94	5.25	2.88	2.88
2.50	3.50	1/2	10	0.63	1.75	1.50	0.44	0.50	5/8-11	1.31	5.38	3.00	3.00
3.25	4.50	3/4	12	0.75	2.00	1.75	0.56	0.69	3/4-10	1.50	6.25	3.50	3.50
4.00	5.00	3/4	12	0.88	2.00	1.75	0.56	0.69	1-8	2.06	6.63	3.75	3.75
5.00	6.50	3/4	12	0.88	2.00	1.75	0.81	1.00	1-8	2.94	7.13	4.25	4.25
6.00	7.50	1	16	1.00	2.25	2.25	0.88	1.25	1 1/4 -7	3.31	8.38	4.88	5.13

¹NPTF ports are available at no extra charge.

²SAE straight thread ports are standard and are indicated by port number.

Style F – Dimensional and Mounting Data

Bore Ø	Rod No.	MM Rod Ø	W	XT	Y	Add Stroke
						ZB Max.
1.50	1 (std.)	0.625	0.63	2.00	2.00	6.25
	2	1.000	1.00	2.38	2.38	6.63
2.00	1 (std.)	1.000	0.75	2.38	2.38	6.69
	2	1.375	1.00	2.63	2.63	6.94
2.50	1 (std.)	1.000	0.75	2.38	2.38	6.81
	2	1.750	1.25	2.88	2.88	7.31
	3	1.375	1.00	2.63	2.63	7.06
3.25	1 (std.)	1.375	0.88	2.75	2.75	7.94
	2	2.000	1.25	3.13	3.13	8.31
	3	1.750	1.13	3.00	3.00	8.19
4.00	1 (std.)	1.750	1.00	3.00	3.00	8.50
	2	2.500	1.38	3.38	3.38	8.88
	3	2.000	1.13	3.13	3.13	8.63
5.00	1 (std.)	2.000	1.13	3.13	3.13	9.38
	2	3.500	1.38	3.38	3.38	9.63
	3	2.500	1.38	3.38	3.38	9.63
	4	3.000	1.38	3.38	3.38	9.63
6.00	1 (std.)	2.500	1.25	3.50	3.50	10.81
	2	4.000	1.25	3.50	3.50	10.81
	3	3.000	1.25	3.50	3.50	10.81
	4	3.500	1.25	3.50	3.50	10.81

Mounting Information – 1.50" to 6.00" Bore Series 2H

Cap Fixed Clevis Mounting
Style BB
(NFPA Style MP1)

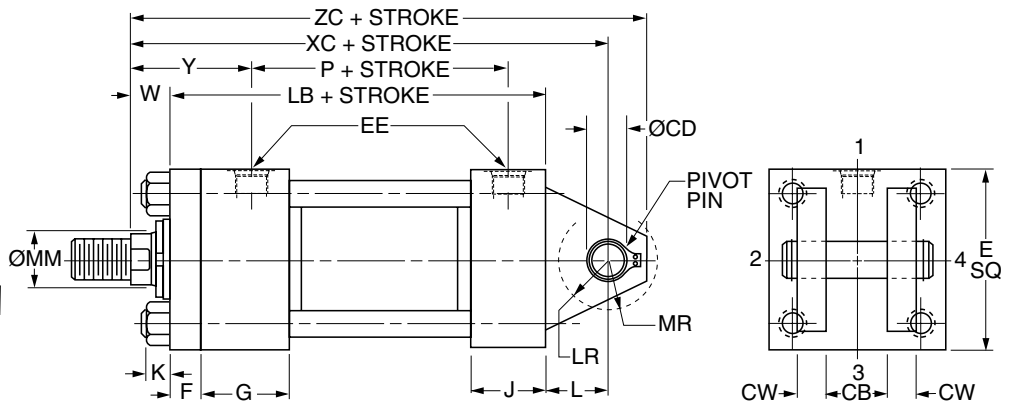
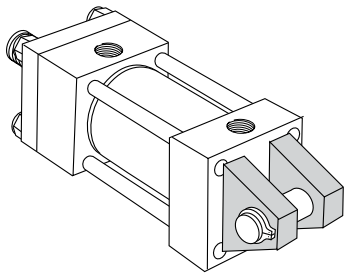

Style BB – Dimensional and Mounting Data

Bore Ø	E	EE		CB	CD ³ Ø +0.000 -0.002	CW	F	G	J	K	L	LR	MR	Add Stroke	
		NPTF ¹	SAE ²											LB	P
1.50	2.50	1/2	10	0.75	.501	0.50	0.38	1.75	1.50	0.38	0.75	0.56	0.63	5.00	2.88
2.00	3.00	1/2	10	1.25	.751	0.63	0.63	1.75	1.50	0.44	1.25	1.00	0.94	5.25	2.88
2.50	3.50	1/2	10	1.25	.751	0.63	0.63	1.75	1.50	0.44	1.25	0.94	0.94	5.38	3.00
3.25	4.50	3/4	12	1.50	1.001	0.75	0.75	2.00	1.75	0.56	1.50	1.25	1.19	6.25	3.50
4.00	5.00	3/4	12	2.00	1.376	1.00	0.88	2.00	1.75	0.56	2.13	1.75	1.63	6.63	3.75
5.00	6.50	3/4	12	2.50	1.751	1.25	0.88	2.00	1.75	0.81	2.25	2.06	2.13	7.13	4.25
6.00	7.50	1	16	2.50	2.001	1.25	1.00	2.25	2.25	0.88	2.50	2.31	2.38	8.38	4.88

¹NPTF ports are available at no extra charge.

²SAE straight thread ports are standard and are indicated by port number.

³Diameter CD is Pin Diameter.

Style BB – Dimensional and Mounting Data

Bore Ø	Rod No.	MM Rod Ø	W	Y	Add Stroke	
					XC	ZC
1.50	1 (std.)	0.625	0.63	2.00	6.38	6.88
	2	1.000	1.00	2.38	6.75	7.25
2.00	1 (std.)	1.000	0.75	2.38	7.25	8.00
	2	1.375	1.00	2.63	7.50	8.25
2.50	1 (std.)	1.000	0.75	2.38	7.38	8.13
	2	1.750	1.25	2.88	7.88	8.63
	3	1.375	1.00	2.63	7.63	8.38
3.25	1 (std.)	1.375	0.88	2.75	8.63	9.63
	2	2.000	1.25	3.13	9.00	10.00
	3	1.750	1.13	3.00	8.88	9.88
4.00	1 (std.)	1.750	1.00	3.00	9.75	11.13
	2	2.500	1.38	3.38	10.13	11.50
	3	2.000	1.13	3.13	9.88	11.25
5.00	1 (std.)	2.000	1.13	3.13	10.50	12.25
	2	3.500	1.38	3.38	10.75	12.50
	3	2.500	1.38	3.38	10.75	12.50
	4	3.000	1.38	3.38	10.75	12.50
6.00	1 (std.)	2.500	1.25	3.50	12.13	14.13
	2	4.000	1.25	3.50	12.13	14.13
	3	3.000	1.25	3.50	12.13	14.13
	4	3.500	1.25	3.50	12.13	14.13



Mounting Information – 1.50" to 6.00" Bore Series 2H

Head Trunnion Mounting
Style D
 (NFPA Style MT1)

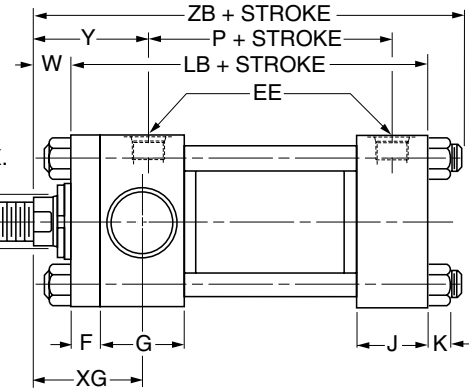
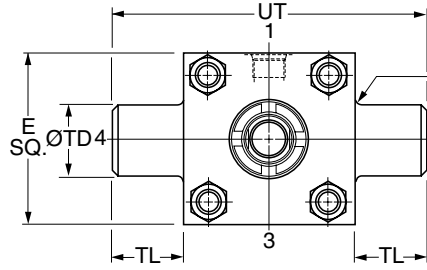
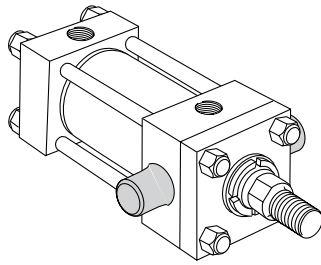

Style D – Dimensional and Mounting Data

Bore Ø	E	EE		F	G	J	K	TD Ø +.000 -.001	TL	UT	Add Stroke	
		NPTF ¹	SAE ²								LB	P
1.50	2.50	1/2	10	0.38	1.75	1.50	0.38	1.000	1.00	4.50	5.00	2.88
2.00	3.00	1/2	10	0.63	1.75	1.50	0.44	1.375	1.38	5.75	5.25	2.88
2.50	3.50	1/2	10	0.63	1.75	1.50	0.44	1.375	1.38	6.25	5.38	3.00
3.25	4.50	3/4	12	0.75	2.00	1.75	0.56	1.750	1.75	8.00	6.25	3.50
4.00	5.00	3/4	12	0.88	2.00	1.75	0.56	1.750	1.75	8.50	6.63	3.75
5.00	6.50	3/4	12	0.88	2.00	1.75	0.81	1.750	1.75	10.00	7.13	4.25
6.00	7.50	1	16	1.00	2.25	2.25	0.88	2.000	2.00	11.50	8.38	4.88

¹NPTF ports are available at no extra charge.

²SAE straight thread ports are standard and are indicated by port number.

Style D – Dimensional and Mounting Data

Bore Ø	Rod No.	MM Rod Ø	W	XG	Y	Add Stroke
						ZB Max.
1.50	1 (std.)	0.625	0.63	1.88	2.00	6.25
	2	1.000	1.00	2.25	2.38	6.63
2.00	1 (std.)	1.000	0.75	2.25	2.38	6.69
	2	1.375	1.00	2.50	2.63	6.94
2.50	1 (std.)	1.000	0.75	2.25	2.38	6.81
	2	1.750	1.25	2.75	2.88	7.31
	3	1.375	1.00	2.50	2.63	7.06
3.25	1 (std.)	1.375	0.88	2.63	2.75	7.94
	2	2.000	1.25	3.00	3.13	8.31
	3	1.750	1.13	2.88	3.00	8.19
4.00	1 (std.)	1.750	1.00	2.88	3.00	8.50
	2	2.500	1.38	3.25	3.38	8.88
	3	2.000	1.13	3.00	3.13	8.63
5.00	1 (std.)	2.000	1.13	3.00	3.13	9.38
	2	3.500	1.38	3.25	3.38	9.63
	3	2.500	1.38	3.25	3.38	9.63
	4	3.000	1.38	3.25	3.38	9.63
6.00	1 (std.)	2.500	1.25	3.38	3.50	10.81
	2	4.000	1.25	3.38	3.50	10.81
	3	3.000	1.25	3.38	3.50	10.81
	4	3.500	1.25	3.38	3.50	10.81

Mounting Information – 1.50" to 6.00" Bore Series 2H

Cap Trunnion Mounting
Style DB
(NFPA Style MT2)

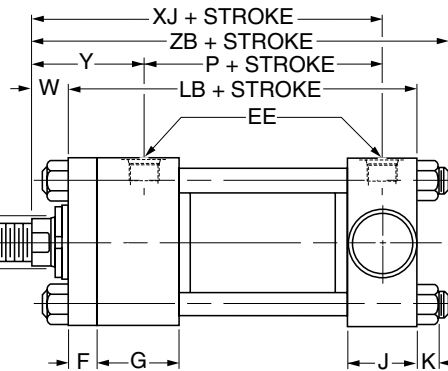
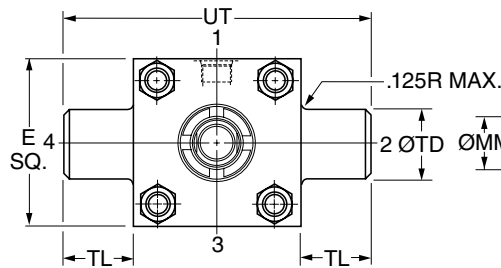
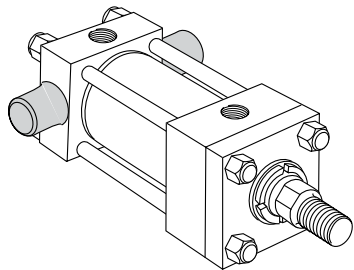

Style DB – Dimensional and Mounting Data

Bore Ø	E	EE		F	G	J	K	TD Ø +0.000 -0.001	TL	UT	Add Stroke	
		NPTF ¹	SAE ²								LB	P
1.50	2.50	1/2	10	0.38	1.75	1.50	0.38	1.000	1.00	4.50	5.00	2.88
2.00	3.00	1/2	10	0.63	1.75	1.50	0.44	1.375	1.38	5.75	5.25	2.88
2.50	3.50	1/2	10	0.63	1.75	1.50	0.44	1.375	1.38	6.25	5.38	3.00
3.25	4.50	3/4	12	0.75	2.00	1.75	0.56	1.750	1.75	8.00	6.25	3.50
4.00	5.00	3/4	12	0.88	2.00	1.75	0.56	1.750	1.75	8.50	6.63	3.75
5.00	6.50	3/4	12	0.88	2.00	1.75	0.81	1.750	1.75	10.00	7.13	4.25
6.00	7.50	1	16	1.00	2.25	2.25	0.88	2.000	2.00	11.50	8.38	4.88

¹NPTF ports are available at no extra charge.

²SAE straight thread ports are standard and are indicated by port number.

Style DB – Dimensional and Mounting Data

Bore Ø	Rod No.	MM Rod Ø	W	Y	Add Stroke	
					XJ	ZB Max.
1.50	1 (std.)	0.625	0.63	2.00	4.88	6.25
	2	1.000	1.00	2.38	5.25	6.63
2.00	1 (std.)	1.000	0.75	2.38	5.25	6.69
	2	1.375	1.00	2.63	5.50	6.94
2.50	1 (std.)	1.000	0.75	2.38	5.38	6.81
	2	1.750	1.25	2.88	5.88	7.31
	3	1.375	1.00	2.63	5.63	7.06
3.25	1 (std.)	1.375	0.88	2.75	6.25	7.94
	2	2.000	1.25	3.13	6.63	8.31
	3	1.750	1.13	3.00	6.50	8.19
4.00	1 (std.)	1.750	1.00	3.00	6.75	8.50
	2	2.500	1.38	3.38	7.13	8.88
	3	2.000	1.13	3.13	6.88	8.63
5.00	1 (std.)	2.000	1.13	3.13	7.38	9.38
	2	3.500	1.38	3.38	7.63	9.63
	3	2.500	1.38	3.38	7.63	9.63
	4	3.000	1.38	3.38	7.63	9.63
6.00	1 (std.)	2.500	1.25	3.50	8.38	10.81
	2	4.000	1.25	3.50	8.38	10.81
	3	3.000	1.25	3.50	8.38	10.81
	4	3.500	1.25	3.50	8.38	10.81



Intermediate Fixed Trunnion Mounting

Style DD
(NFPA Style MT4)

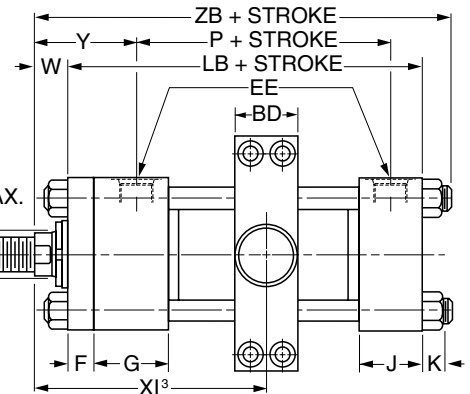
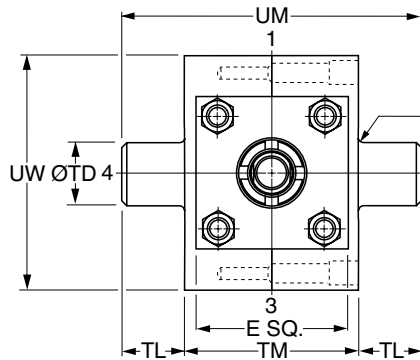
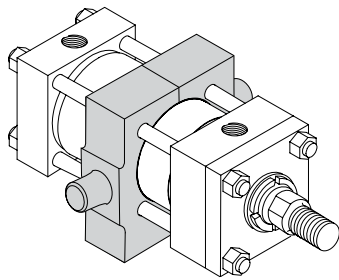

Style DD – Dimensional and Mounting Data

Bore Ø	BD	E	EE		F	G	J	K	TD Ø +0.000 -0.001	TL	TM	UM	UW	Add Stroke	
			NPTF ¹	SAE ²										LB	P
1.50	1.25	2.50	1/2	10	0.38	1.75	1.50	0.38	1.000	1.00	3.00	5.00	3.38	5.00	2.88
2.00	1.50	3.00	1/2	10	0.63	1.75	1.50	0.44	1.375	1.38	3.50	6.25	4.13	5.25	2.88
2.50	1.50	3.50	1/2	10	0.63	1.75	1.50	0.44	1.375	1.38	4.00	6.75	4.63	5.38	3.00
3.25	2.00	4.50	3/4	12	0.75	2.00	1.75	0.56	1.750	1.75	5.00	8.50	5.81	6.25	3.50
4.00	2.00	5.00	3/4	12	0.88	2.00	1.75	0.56	1.750	1.75	5.50	9.00	6.38	6.63	3.75
5.00	2.00	6.50	3/4	12	0.88	2.00	1.75	0.81	1.750	1.75	7.00	10.50	7.75	7.13	4.25
6.00	3.00	7.50	1	16	1.00	2.25	2.25	0.88	2.000	2.00	8.50	12.50	10.38	8.38	4.88

¹NPTF ports are available at no extra charge.

²SAE straight thread ports are standard and are indicated by port number.

Style DD – Dimensional and Mounting Data

Bore Ø	Rod No.	MM Rod Ø	W	Y	Min. XI ³	Min. Stroke	Add Stroke	
							Max. XI ⁴	ZB Max
1.50	1 (std.)	0.625	0.63	2.00	3.44	0	3.44	6.25
	2	1.000	1.00	2.38	3.81	0	3.81	6.63
2.00	1 (std.)	1.000	0.75	2.38	3.94	0.25	3.69	6.69
	2	1.375	1.00	2.63	4.19	0.25	3.94	6.94
2.50	1 (std.)	1.000	0.75	2.38	3.94	0.13	3.81	6.81
	2	1.750	1.25	2.88	4.44	0.13	4.31	7.31
	3	1.375	1.00	2.63	4.19	0.13	4.06	7.06
3.25	1 (std.)	1.375	0.88	2.75	4.69	0.38	4.31	7.94
	2	2.000	1.25	3.13	5.06	0.38	4.69	8.31
	3	1.750	1.13	3.00	4.94	0.38	4.56	8.19
4.00	1 (std.)	1.750	1.00	3.00	4.94	0.13	4.81	8.50
	2	2.500	1.38	3.38	5.31	0.13	5.19	8.88
	3	2.000	1.13	3.13	5.06	0.13	4.94	8.63
5.00	1 (std.)	2.000	1.13	3.13	5.06	0	5.44	9.38
	2	3.500	1.38	3.38	5.31	0	5.69	9.63
	3	2.500	1.38	3.38	5.31	0	5.69	9.63
	4	3.000	1.38	3.38	5.31	0	5.69	9.63
6.00	1 (std.)	2.500	1.25	3.50	6.06	0.25	5.81	10.81
	2	4.000	1.25	3.50	6.06	0.25	5.81	10.81
	3	3.000	1.25	3.50	6.06	0.25	5.81	10.81
	4	3.500	1.25	3.50	6.06	0.25	5.81	10.81

³Dimension XI to be specified by customer.

⁴Dimensions shown are valid for standard W dimension.



Mounting Information – 1.50" to 6.00" Bore Series 2H

Heavy Duty Intermediate Fixed Trunnion Mounting

Style DE
(NFPA Style MT4)

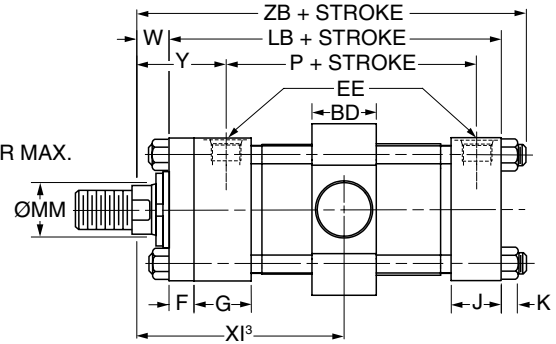
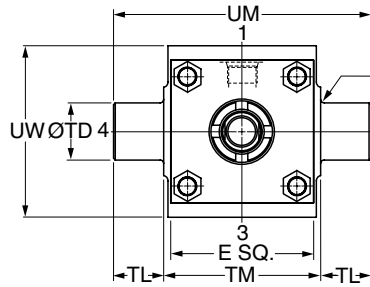
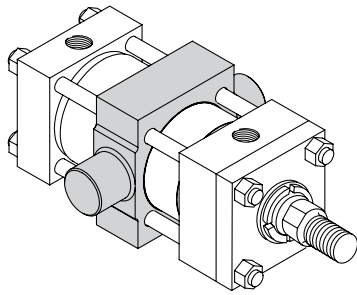

Style DE – Dimensional and Mounting Data

Bore Ø	BD	E	EE		F	G	J	K	TD Ø +.000 -.001	TL	TM	UM	UW	Add Stroke		Style DE Minimum Stroke
			NPTF ¹	SAE ²										LB	P	
4.00	2.25	5.00	3/4	12	0.88	2.00	1.75	0.56	2.000	1.75	5.50	9.00	6.00	6.63	3.75	0.38
5.00	2.75	6.50	3/4	12	0.88	2.00	1.75	0.81	2.500	1.75	7.00	10.50	7.50	7.13	4.25	0.38
6.00	3.25	7.50	1	16	1.00	2.25	2.25	0.88	3.000	2.00	8.50	12.50	9.50	8.38	4.88	0.50

¹NPTF ports are available at no extra charge.

²SAE straight thread ports are standard and are indicated by port number.

Style DE – Dimensional and Mounting Data

Bore Ø	Rod No.	MM Rod Ø	Min. XI ³	W	Y	Add Stroke	
						Max. XI ⁴	ZB Max.
4.00	1 (std.)	1.750	5.06	1.00	3.00	4.69	8.50
	2	2.500	5.44	1.38	3.38	5.06	8.88
	3	2.000	5.19	1.13	3.13	4.81	8.63
5.00	1 (std.)	2.000	5.44	1.13	3.13	5.06	9.38
	2	3.500	5.69	1.38	3.38	5.31	9.63
	3	2.500	5.69	1.38	3.38	5.31	9.63
	4	3.000	5.69	1.38	3.38	5.31	9.63
6.00	1 (std.)	2.500	6.19	1.25	3.50	5.69	10.81
	2	4.000	6.19	1.25	3.50	5.69	10.81
	3	3.000	6.19	1.25	3.50	5.69	10.81
	4	3.500	6.19	1.25	3.50	5.69	10.81

³Dimension XI to be specified by customer.

⁴Dimensions shown are valid for standard W dimension.



Mounting Information – 1.50" to 6.00" Bore Series 2H

Spherical Bearing Mounting
Style SB

Bore Ø	Maximum Operating psi ¹
1.50	1500
2.00	2200
2.50	1450
3.25	1500
4.00	1850
5.00	2000
6.00	1800

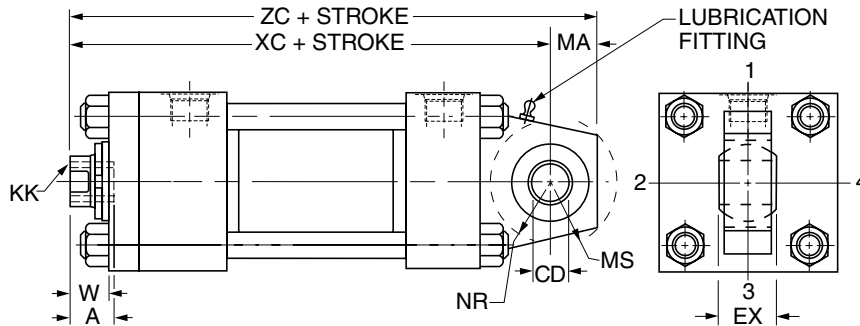

Style SB — Dimensional and Mounting Data

Bore Ø	Rod No.	MM Rod Ø	Thread		A	CD ² Ø	EX	MA	MS	NR	W	Add Stroke	
			Style 9 KK ³	Style 7 KK ³								XC	ZC
1.50	1 (Std.)	0.625	7/16-20	—	0.75	-.0005 .5000	0.44	0.75	0.94	0.63	0.63	6.38	7.13
	2	1.000	—	7/16-20	0.75							6.75	7.50
2.00	1 (Std.)	1.000	3/4-16	—	1.13	-.0005 .7500	0.66	1.00	1.38	1.00	0.75	7.25	8.25
	2	1.375	—	3/4-16	1.13							7.50	8.50
2.50	1 (Std.)	1.000	3/4-16	—	1.13	-.0005 .7500	0.66	1.00	1.38	1.00	0.75	7.38	8.38
	2	1.750	—	3/4-16	1.13							7.88	8.88
	3	1.375	—	3/4-16	1.13							7.63	8.63
3.25	1 (Std.)	1.375	1-14	—	1.63	-.0005 1.0000	0.88	1.25	1.69	1.25	0.88	8.63	9.88
	2	2.000	—	1-14	1.63							9.00	10.25
	3	1.750	—	1-14	1.63							8.88	10.13
4.00	1 (Std.)	1.750	1 1/4-12	—	2.00	-.0005 1.3750	1.19	1.88	2.44	1.63	1.00	9.75	11.63
	2	2.500	—	1 1/4-12	2.00							10.13	12.00
	3	2.000	—	1 1/4-12	2.00							9.88	11.75
5.00	1 (Std.)	2.000	1 1/2-12	—	2.25	-.0005 1.7500	1.53	2.50	2.88	2.06	1.13	10.50	13.00
	2	3.500	—	1 1/2-12	2.25							10.75	13.25
	3	2.500	—	1 1/2-12	2.25							10.75	13.25
	4	3.000	—	1 1/2-12	2.25							10.75	13.25
6.00	1 (Std.)	2.500	1 7/8-12	—	3.00	-.0005 2.0000	1.75	2.50	3.31	2.38	1.25	12.13	14.63
	2	4.000	—	1 7/8-12	3.00							12.13	14.63
	3	3.000	—	1 7/8-12	3.00							12.13	14.63
	4	3.500	—	1 7/8-12	3.00							12.13	14.63

Note: for additional dimensions see Series 2H Style BB mount.

¹ Maximum operating pressure at 4:1 design factor is based on tensile strength of material. Pressure ratings are based on standard commercial bearing ratings.

² Dimension "CD" is hole diameter.

³ Threads listed are also for a spherical rod eye which match style 9 or style 7. The spherical rod eye pin diameter matches the cap pin and (if required) needs to be purchased separately; see 2H/3H mounting accessories for detailed information.

Style SB – Recommended maximum swivel angle on each side of the cylinder centerline.

Bore Ø	Head End Mounted		Cap End Mounted	
	Angle a	Tan. of a	Angle a	Tan. of a
1.50	2.00°	.035	2.00°	.035
2.00	2.50°	.044	4.50°	.079
2.50	2.50°	.044	4.50°	.079
3.25	3.00°	.052	3.00°	.052
4.00	2.50°	.044	3.00°	.052
5.00	3.00°	.052	3.00°	.052
6.00	3.00°	.052	3.00°	.052

Note: Dimension X is the maximum off center mounting of the cylinder. To determine dimension X for various stroke lengths multiply the distance between pivot pin holes by tangent of angle a. For extended position use X = XL + 2X stroke.

Mounting Information

Head End Mounting

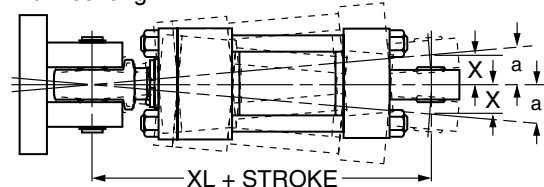

Cap End Mounting

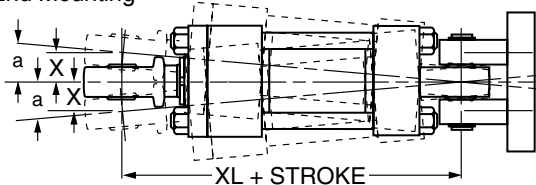

**Double Rod Cylinder
Style K**

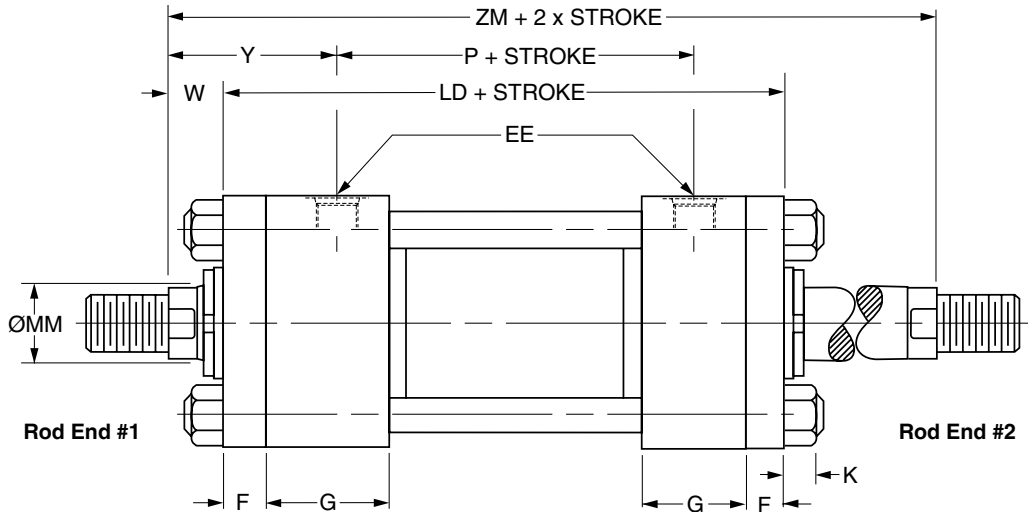

Mounting Styles for Single Rod Models	Mounting Styles for Corresponding Double Rod Models ¹	Dimensions Shown on This Page Supplement Dimensions on Pages Listed Below
		1.50" - 6.00" Bores Page No.
T	KT	12
TB	KTB	12
TD	KTD	12
J	KJ	13
JB	KJB	14
JJ	KJJ	15
C	KC	19
F	KF	20
D	KD	22
DD	KDD ²	24
DE	KDE ²	25

¹ If only one end of these Double Rod Cylinders is to be cushioned, be sure to specify clearly which end this will be.

² Specify XI dimension from rod end #1.

Bore Ø	Rod No.	MM Rod Ø	Add Stroke			Add 2X Stroke
			LD	SNK	SSK	ZM
1.50	1 (std.)	0.625	5.63	2.88	4.13	6.88
	2	1.000	5.63	2.88	4.13	7.63
2.00	1 (std.)	1.000	6.13	2.88	3.88	7.63
	2	1.375	6.13	2.88	3.88	8.13
2.50	1 (std.)	1.000	6.25	3.00	3.63	7.75
	2	1.750	6.25	3.00	3.63	8.75
	3	1.375	6.25	3.00	3.63	8.25
3.25	1 (std.)	1.375	7.25	3.50	4.38	9.00
	2	2.000	7.25	3.50	4.38	9.75
	3	1.750	7.25	3.50	4.38	9.50
4.00	1 (std.)	1.750	7.75	3.75	4.25	9.75
	2	2.500	7.75	3.75	4.25	10.50
	3	2.000	7.75	3.75	4.25	10.00
5.00	1 (std.)	2.000	8.25	4.25	4.75	10.50
	2	3.500	8.25	4.25	4.75	11.00
	3	2.500	8.25	4.25	4.75	11.00
	4	3.000	8.25	4.25	4.75	11.00
6.00	1 (std.)	2.500	9.38	4.88	5.13	11.88
	2	4.000	9.38	4.88	5.13	11.88
	3	3.000	9.38	4.88	5.13	11.88
	4	3.500	9.38	4.88	5.13	11.88
Replaces On single rod mounting styles:			LB	SN	SS	-
			All Mtg. Styles	F	C	All Mtg. Styles

**How to Use Double Rod Cylinder
Dimension Drawings**

To determine dimensions for a double rod cylinder, first refer to the desired single rod mounting style cylinder shown on preceding pages of this catalog. (See table above.) After selecting necessary dimensions from that drawing, return to this page supplement the single rod dimensions with those shown on drawing at right and dimension table below. Note that double rod cylinders have a head (Dim. G) at both ends and that dimension LD replaces LB. The double rod dimensions differ from, or are in addition to those for single

rod cylinders shown on preceding pages and provide the information needed to completely dimension a double rod cylinder.

On a double rod cylinder where the two rod ends are different, be sure to clearly state which rod end is to be assembled at which end. Port position 1 is standard. If other than standard, specify pos. 2, 3 or 4 when viewed from rod end #1 only. See port position information in Section E.

Bolt-On Gland Option Series 2HD & 3HD Heavy Duty Hydraulic Cylinders

.....



.....

Now Featuring Optional Bolt-On Gland

For 1.50"-6.00" Bore Series 2H and
7.00" & 8.00" Bore Series 3H Cylinders

- Non-threaded gland is clamped between bolt-on circular retainer and head for simplified service
- Polyurethane Rod Seal with multiple sealing edges for leak proof service
- Long inboard rod bearing surface that is lubricated from within

Parker Series 2HD & 3HD – your best choice in heavy duty hydraulic cylinders

Parker Series 2HD and 3HD hydraulic cylinders offer increased durability and ease of service with the addition of a bolt-on rod gland. The 2HD/3HD rod gland was designed to withstand the toughest applications while maintaining the original dimensional envelope of the

Series 2H and 3H cylinder. When requesting this option, please take note of the following page that depicts rod gland retainer dimensions unique to the rod end of the 2HD/3HD cylinder. All other dimensions will remain the same as the standard Series 2H or 3H cylinder.

Primary Seal – Polyurethane Rod Seal is a proven leak proof design – completely self-compensating and self-relieving to withstand variations and conform to mechanical deflection that may occur. Alternative seal materials are available to suit your application.

Secondary Seal – Rod Wiper – wipes clean any oil film adhering to the rod on the extend stroke and cleans the rod on the return stroke.

Rod Gland Assembly – Bronze gland is externally removable without cylinder disassembly. Long inboard bearing surface is ahead of the seals assuring lubrication by cylinder operating fluid.

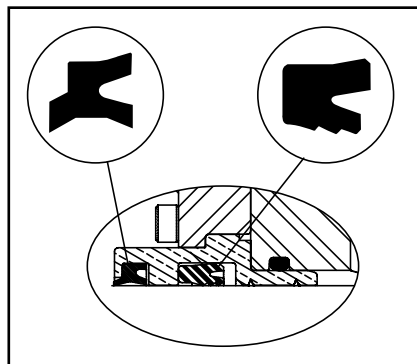
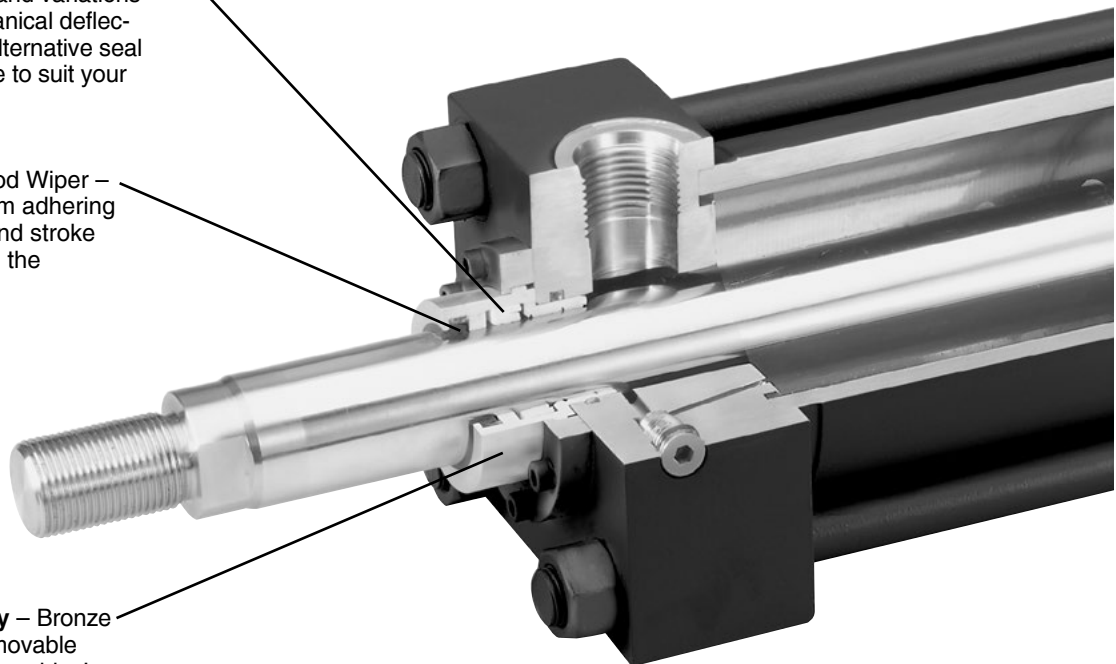

Gland Assembly

Gland Assembly is externally removable without cylinder disassembly. An O-ring is used as a seal between the gland and head. The rod seal has multiple sealing edges to produce “dry rod” performance. It is molded from a special polyurethane material that is extremely resistant to abrasion and extrusion, resulting in exceptional service life. Wiperseal cleans rod of dirt, preventing it from entering the gland and also acts as a secondary rod seal.



2HD / 3HD Rod Gland Dimensional Comparison

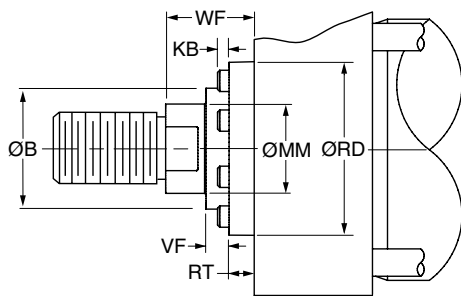

Bolt On Rod Gland (B)

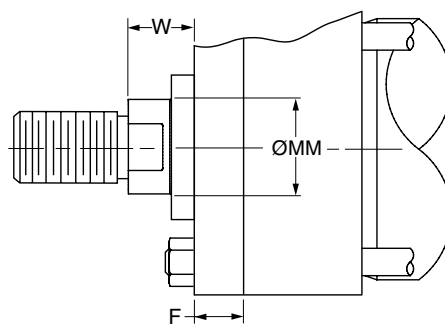

Tie Rod Retained Gland (R)

Bore Ø	Rod No.	MM Rod Ø	2HD Rod Gland Retention ²				Bolt On Rod Gland Dimensions							
			Mounting Style				B Ø +0.000 -0.002	RD Ø	RT	KB	VF	W	WF	F
			TC, H, HB, HH, C, F, D, DB, DD, DE, BB, SB	TB, TD	J, JB ¹	JJ								
1.50	1 (Std.)	0.625	B	R	R	B	1.124	1.94	0.38	0.19	0.25	0.63	1.00	0.38
	2	1.000	R	R	R	B	1.499	2.38	0.38	- ³	0.50	1.00	1.38	0.38
2.00	1 (Std.)	1.000	B	R	R	B	1.499	2.38	0.38	0.19	0.50	0.75	1.38	0.63
	2	1.375	R	R	R	B	1.999	2.88	0.38	- ³	0.63	1.00	1.63	0.63
2.50	1 (Std.)	1.000	B	B	B	B	1.499	2.38	0.38	0.19	0.50	0.75	1.38	0.63
	2	1.750	B	B	R	B	2.374	3.47	0.63	0.19	0.50	1.25	1.88	0.63
	3	1.375	B	B	B	B	1.999	2.88	0.38	0.19	0.63	1.00	1.63	0.63
3.25	1 (Std.)	1.375	B	B	B	B	1.999	2.88	0.38	0.19	0.63	0.88	1.63	0.75
	2	2.000	B	B	B	B	2.624	3.72	0.63	0.25	0.50	1.25	2.00	0.75
	3	1.750	B	B	B	B	2.374	3.47	0.63	0.19	0.50	1.13	1.88	0.75
4.00	1 (Std.)	1.750	B	B	B	B	2.374	3.47	0.63	0.19	0.50	1.00	1.88	0.88
	2	2.500	B	B	B	B	3.124	4.25	0.63	0.25	0.63	1.38	2.25	0.88
	3	2.000	B	B	B	B	2.624	3.72	0.63	0.25	0.50	1.13	2.00	0.88
5.00	1 (Std.)	2.000	B	B	B	B	2.624	3.72	0.63	0.25	0.50	1.13	2.00	0.88
	2	3.500	B	B	R	B	4.249	5.94	0.94	-	0.31	1.38	2.25	0.88
	3	2.500	B	B	B	B	3.124	4.25	0.63	0.25	0.63	1.38	2.25	0.88
	4	3.000	B	B	B	B	3.749	5.44	0.88	-	0.31	1.38	2.25	0.88
6.00	1 (Std.)	2.500	B	B	B	B	3.124	4.25	0.63	0.25	0.63	1.25	2.25	1.00
	2	4.000	B	B	B	B	4.749	6.31	0.94	-	0.31	1.25	2.25	1.00
	3	3.000	B	B	B	B	3.749	5.44	0.88	-	0.31	1.25	2.25	1.00
	4	3.500	B	B	B	B	4.249	5.94	0.94	-	0.31	1.25	2.25	1.00
7.00	1 (Std.)	3.000	B	B	B	B	3.749	5.44	0.88	-	0.31	-	2.25	1.00
	2	5.000	B	B	B	B	5.749	7.44	0.94	-	0.31	-	2.25	1.00
	3	3.500	B	B	B	B	4.249	5.94	0.94	-	0.31	-	2.25	1.00
	4	4.000	B	B	B	B	4.749	6.31	0.94	-	0.31	-	2.25	1.00
	5	4.500	B	B	B	B	5.249	6.94	0.94	-	0.31	-	2.25	1.00
8.00	1 (Std.)	3.500	B	B	B	B	4.249	5.94	0.94	-	0.31	-	2.25	1.00
	2	5.500	B	B	B	B	6.249	7.94	0.94	-	0.31	-	2.25	1.00
	3	4.000	B	B	B	B	4.749	6.31	0.94	-	0.31	-	2.25	1.00
	4	4.500	B	B	B	B	5.249	6.94	0.94	-	0.31	-	2.25	1.00
	5	5.000	B	B	B	B	5.749	7.44	0.94	-	0.31	-	2.25	1.00

B = Bolt-On Gland with Circular Retainer

R = Tie Rod Retained Gland

¹ 2H J & JB Mounts have reduced pressure ratings. Refer to J and JB mounts in 2H Section for de-rated operating pressure associated with the use of the 2HD gland.

² Gland retention style may vary when thrust key retainer or gland drain option is included. Contact factory for details.

³ KB dimension in these sizes is 0.19 for mounting Style JJ

Section B

Series 3H High Pressure Hydraulic Cylinders

	7.00" & 8.00" Bore	10.00" through 20.00" Bore
Performance	32	32
Specifications	33	33
Specifications, Mounting Styles	34	35
3H Cylinder Model Code & How to Order	36, 37	36, 37
Rod End Styles and Dimensions	38	39
TD, TB, TC Dimensions	40	53
H Mount Dimensions	41	–
HB Mount Dimensions	42	58
HH Mount Dimensions	42	57
J Mount Dimensions	43	–
JB Mount Dimensions	44	56
JJ Mount Dimensions	45	54, 55
C Mount Dimensions	46	59
F Mount Dimensions	46	–
BB Mount Dimensions	47	60
D Mount Dimensions	48	61
DB Mount Dimensions	49	62
DD Mount Dimensions	50	63
DE Mount Dimensions	51	–
Double Rod Cylinders	52	64



The large bore, high pressure hydraulic cylinder Parker designed to meet your needs

Parker Series 3H cylinders provide unmatched reliability, performance, and innovative design features that aid in increasing productivity while reducing operating costs.

Parker's externally removable bolt-on gland assembly makes preventive and routine maintenance quick and easy! In many cases, the cylinder does not have to be removed or disassembled to facilitate service. Our innovative design provides for fast turn around, reduced downtime, and increased productivity.

In addition to our removable gland assembly, Series 3H cylinders also include a multitude of innovative design

features such as: anti-extrusion body end seals, floating cushions, hi load piston (standard), and various port and rod end options to meet your application requirements.

Every Series 3H cylinder is individually tested before leaving our plant to assure proper and leak free operation. All Series 3H cylinders come with an eighteen month warranty standard.



High Pressure Hydraulic Cylinders Series 3H 7.00" through 20.00"

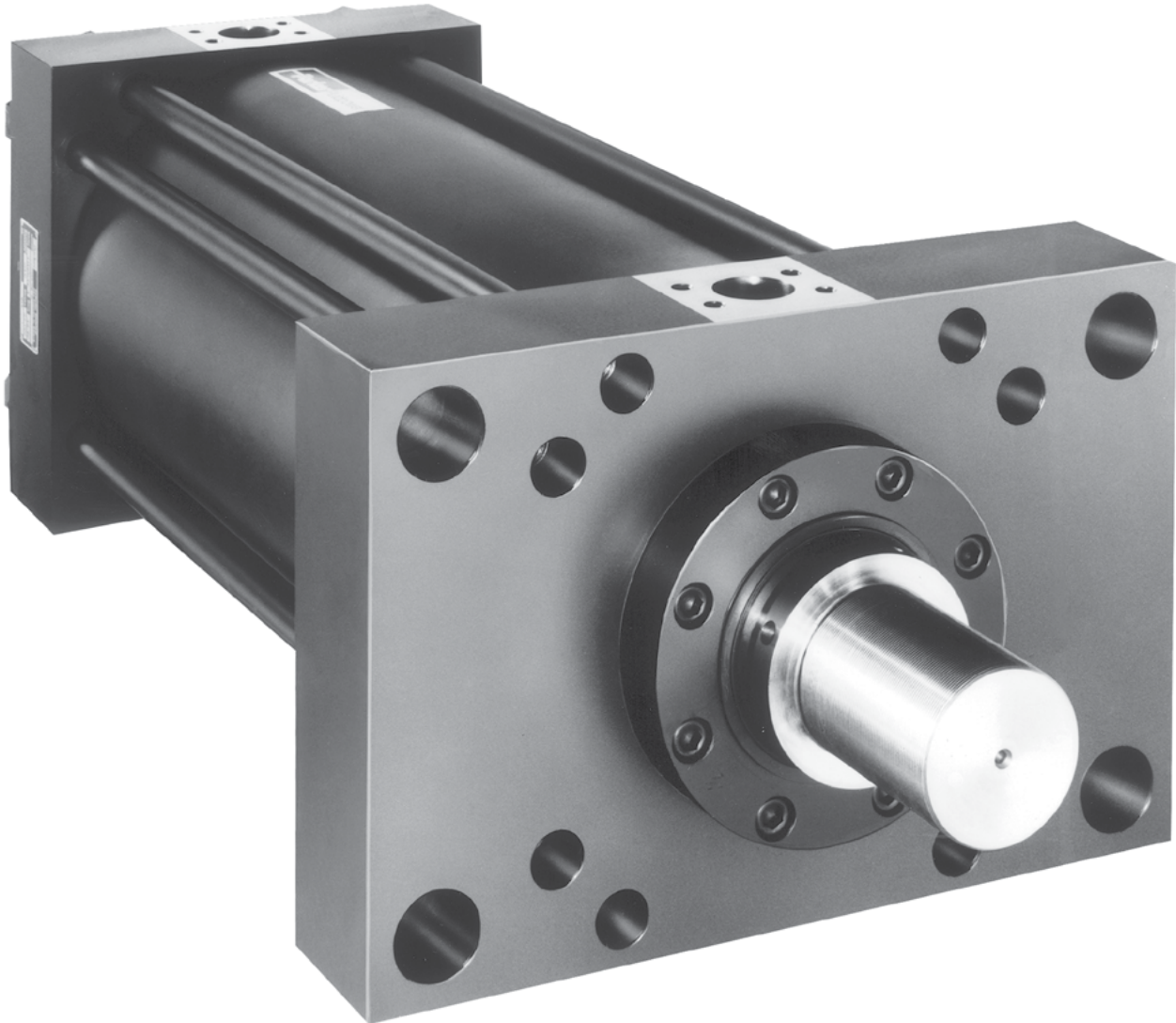

B

Heavy Duty Service – Industrial Tie-Rod Construction

- Nominal Pressure – 3000 psi
- Sixteen Standard Mounting Styles –
7.00" and 8.00" Bore
- Twelve Standard Mounting Styles –
10.00" through 20.00" Bore

Specifications / Mountings – 7.00" and 8.00" Series 3H

Standard Specifications

- Heavy Duty Service — ANSI/(NFPA) T3.6.7R3 - 2009 Specifications and Mounting Dimension Standards
- Standard Construction — Square Head – Tie Rod Design
- Nominal Pressure — 3000 psi¹
- Standard Fluid — Hydraulic Oil
- Standard Temperature — -10°F to +165°F²
- Piston Rod Diameter — 3.000" through 5.500"

In line with our policy of continuing product improvement, specifications in this catalog are subject to change.

- Mounting Styles — 16 standard styles at various application ratings
- Strokes — Available in any practical stroke length
- Cushions — Optional at either end or both ends of stroke
- Rod Ends — Four Standard Choices — specials to order

¹ If hydraulic operating pressure exceeds 3000 psi, send application data for engineering evaluation and recommendation. See Section E for actual design factors.

² See Section E for higher temperature service.

Available Mounting Styles

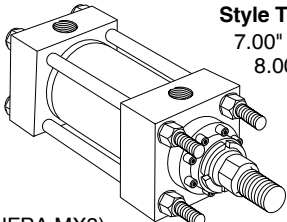
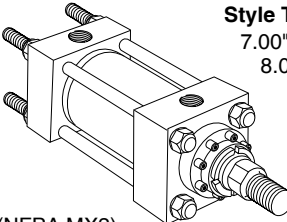
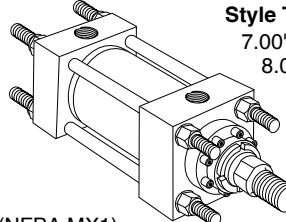
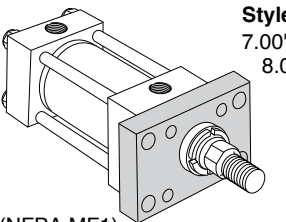
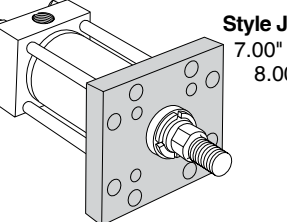
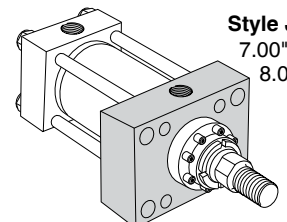
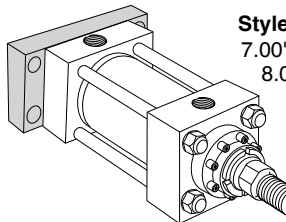
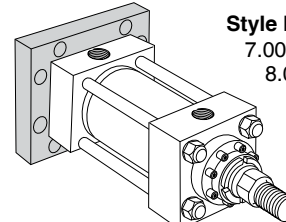
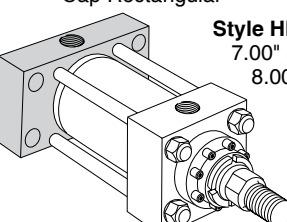
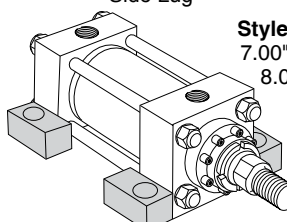
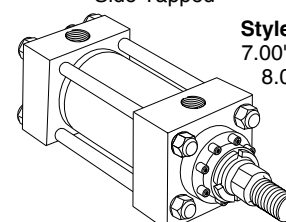
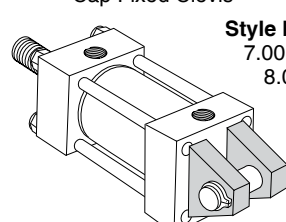
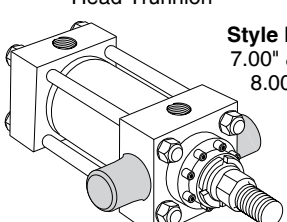
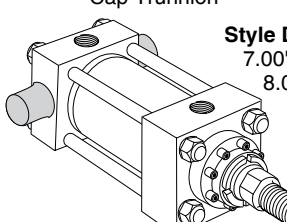
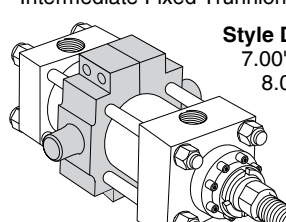
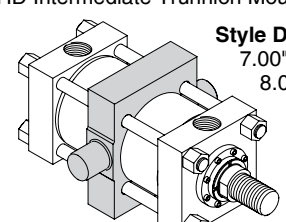
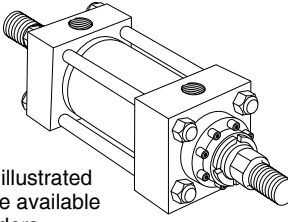
<p>Tie Rods Extended Head End</p>  <p>Style TB 7.00" & 8.00"</p> <p>(NFPA MX3)</p>	<p>Tie Rods Extended Cap End</p>  <p>Style TC 7.00" & 8.00"</p> <p>(NFPA MX2)</p>	<p>Tie Rods Extended Both Ends</p>  <p>Style TD 7.00" & 8.00"</p> <p>(NFPA MX1)</p>	<p>Head Rectangular Flange</p>  <p>Style J 7.00" & 8.00"</p> <p>(NFPA MF1)</p>
<p>Head Square Flange</p>  <p>Style JB 7.00" & 8.00"</p> <p>(NFPA MF5)</p>	<p>Head Rectangular</p>  <p>Style JJ 7.00" & 8.00"</p> <p>(NFPA ME5)</p>	<p>Cap Rectangular Flange</p>  <p>Style H 7.00" & 8.00"</p> <p>(NFPA MF2)</p>	<p>Cap Square Flange</p>  <p>Style HB 7.00" & 8.00"</p> <p>(NFPA MF6)</p>
<p>Cap Rectangular</p>  <p>Style HH 7.00" & 8.00"</p> <p>(NFPA ME6)</p>	<p>Side Lug</p>  <p>Style C 7.00" & 8.00"</p> <p>(NFPA MS2)</p>	<p>Side Tapped</p>  <p>Style F 7.00" & 8.00"</p> <p>(NFPA MS4)</p>	<p>Cap Fixed Clevis</p>  <p>Style BB 7.00" & 8.00"</p> <p>(NFPA MP1)</p>
<p>Head Trunnion</p>  <p>Style D 7.00" & 8.00"</p> <p>(NFPA MT1)</p>	<p>Cap Trunnion</p>  <p>Style DB 7.00" & 8.00"</p> <p>(NFPA MT2)</p>	<p>Intermediate Fixed Trunnion</p>  <p>Style DD 7.00" & 8.00"</p> <p>(NFPA MT4)</p>	<p>HD Intermediate Trunnion Mount</p>  <p>Style DE¹ 7.00" & 8.00"</p> <p>(NFPA MT4)</p>
<p>Double Rod Cylinders</p>  <p>Style KT Shown</p>			

Most of the above illustrated mounting styles are available in double rod cylinders.

¹Style DE Mount conforms to NFPA MT4 dimensional standard.
NOTE: Series 3H Hydraulic Cylinders fully meet ANSI/(NFPA) T3.6.7R2 - 1996 Specifications and Mounting Dimension Standards for Square Head Industrial Fluidpower Cylinders.

Standard Specifications

- Heavy Duty Service
- Standard Construction – Square Head – Tie Rod Design
- Nominal Pressure – 3000 psi¹
- Standard Fluid – Hydraulic Oil
- Standard Temperature – -10°F to +165°F²
- Bore Sizes – 10.00" through 20.00" (Larger sizes available)
- Piston Rod Diameter – 4.500" through 10.000"
- Mounting Styles – 12 standard styles at various application ratings
- Strokes – Available in any practical stroke length
- Cushions – Optional at either end or both ends of stroke
- Rod Ends – Three Standard Choices – Specials to Order

¹ If hydraulic operating pressure exceeds 3000 psi, send application data for engineering evaluation and recommendation. See Section E for actual design factors.

² See Section E for higher temperature service.

In line with our policy of continuing product improvement, specifications in this catalog are subject to change.

Available Mounting Styles

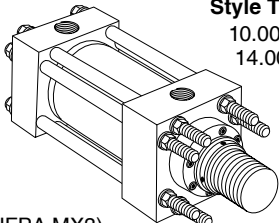
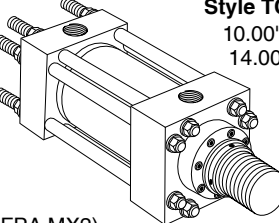
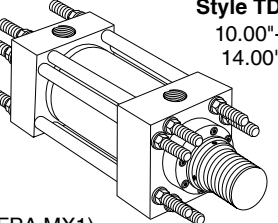
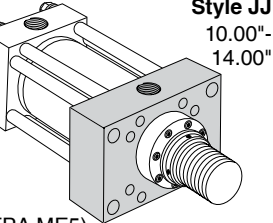
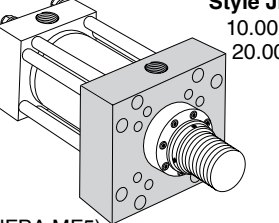
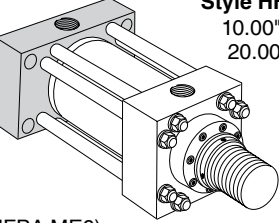
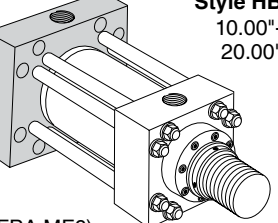
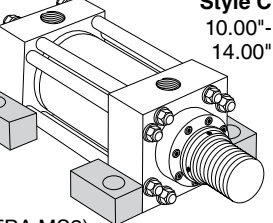
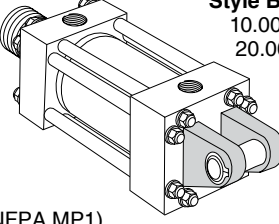
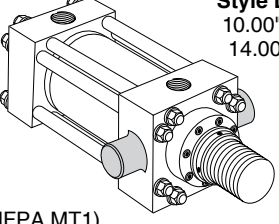
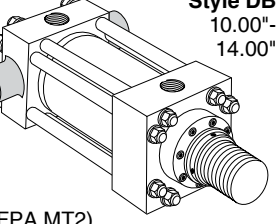
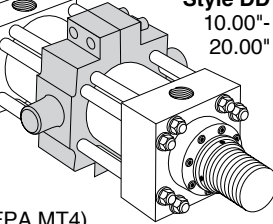
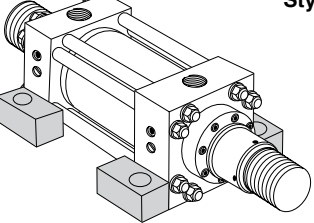
<p>Tie Rods Extended Head End</p>  <p>Style TB 10.00"-14.00"</p> <p>(NFPA MX3)</p>	<p>Tie Rods Extended Cap End</p>  <p>Style TC 10.00"-14.00"</p> <p>(NFPA MX2)</p>	<p>Tie Rods Extended Both Ends</p>  <p>Style TD 10.00"-14.00"</p> <p>(NFPA MX1)</p>	<p>Head Rectangular</p>  <p>Style JJ 10.00"-14.00"</p> <p>(NFPA ME5)</p>	
<p>Head Square Flange</p>  <p>Style JB 10.00"-20.00"</p> <p>(NFPA MF5)</p>	<p>Cap Rectangular</p>  <p>Style HH 10.00"-20.00"</p> <p>(NFPA ME6)</p>	<p>Cap Square Flange</p>  <p>Style HB 10.00"-20.00"</p> <p>(NFPA MF6)</p>	<p>Side Lug</p>  <p>Style C 10.00"-14.00"</p> <p>(NFPA MS2)</p>	
<p>Cap Fixed Clevis</p>  <p>Style BB 10.00"-20.00"</p> <p>(NFPA MP1)</p>	<p>Head Trunnion</p>  <p>Style D 10.00"-14.00"</p> <p>(NFPA MT1)</p>	<p>Cap Trunnion</p>  <p>Style DB 10.00"-14.00"</p> <p>(NFPA MT2)</p>	<p>Intermediate Fixed Trunnion</p>  <p>Style DD 10.00"-20.00"</p> <p>(NFPA MT4)</p>	
<p>Double Rod Cylinders</p>  <p>Style KC Shown</p> <p>Most of the above illustrated mounting styles are available in double rod cylinders.</p>				



3H Model Code

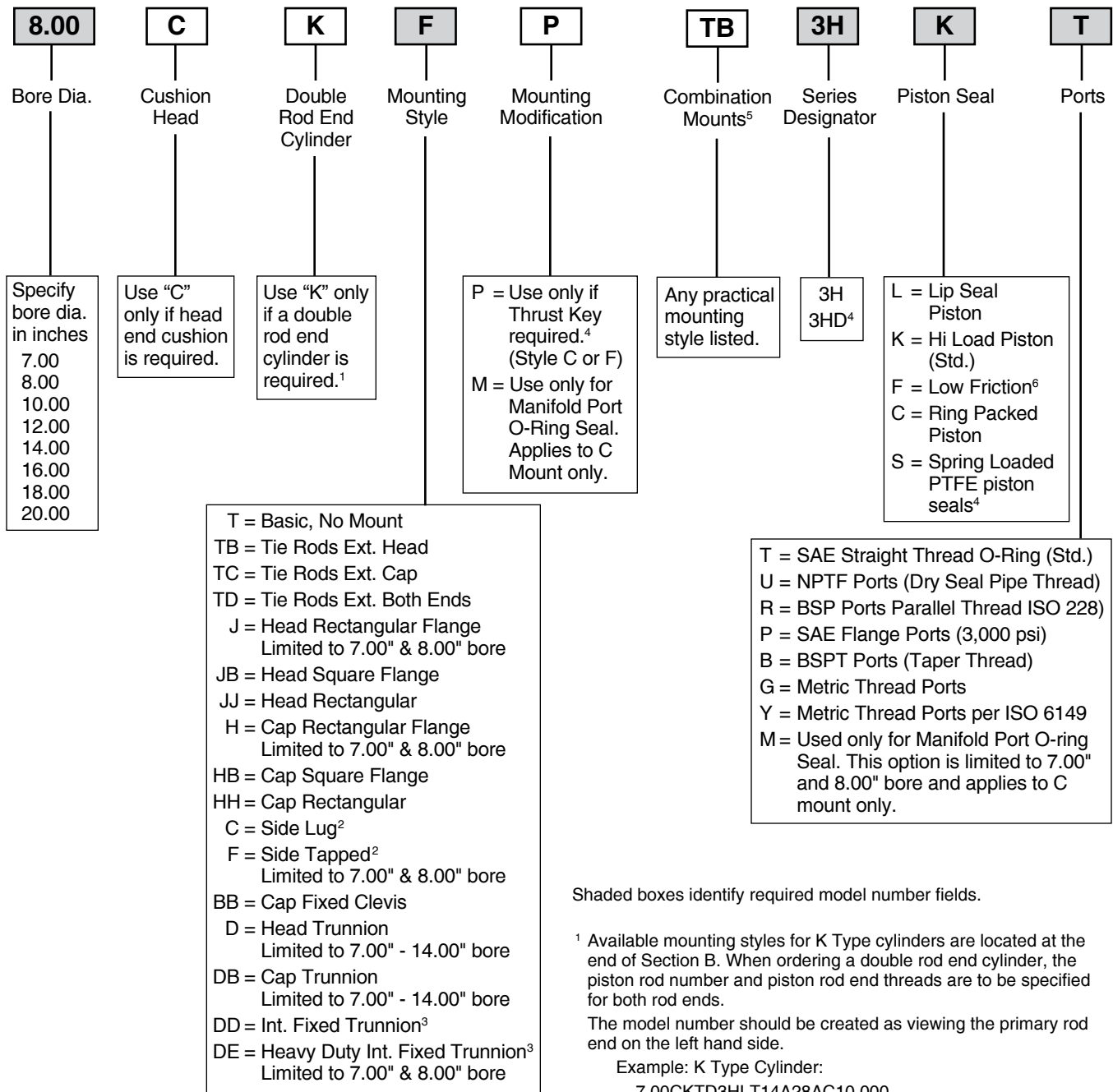

Shaded boxes identify required model number fields.

¹ Available mounting styles for K Type cylinders are located at the end of Section B. When ordering a double rod end cylinder, the piston rod number and piston rod end threads are to be specified for both rod ends.

The model number should be created as viewing the primary rod end on the left hand side.

Example: K Type Cylinder:
7.00CKTD3HLT14A28AC10.000

² Mounting Styles C and F should have a minimum stroke length equal to or greater than their bore size.

³ Specify XI dimension.

⁴ Limited to 7.00" and 8.00" bore.

⁵ In general, the model numbers as read left to right corresponding to the cylinder as viewed from left to right with the primary end at the left. The second or subsequent mountings are mountings called out as they appear in the assembly moving away from the rod end. Except when tie rod extension mountings are part of a combination, all combinations should have a "S" (Special) in the model code and a note in the body of the order clarifying the mounting arrangement. The "P", as used to define a thrust key is not considered to be a mounting. However it is located at the primary end.

⁶ Low Friction Piston Seal limited to 7.00" and 8.00" bore.



3H Model Code

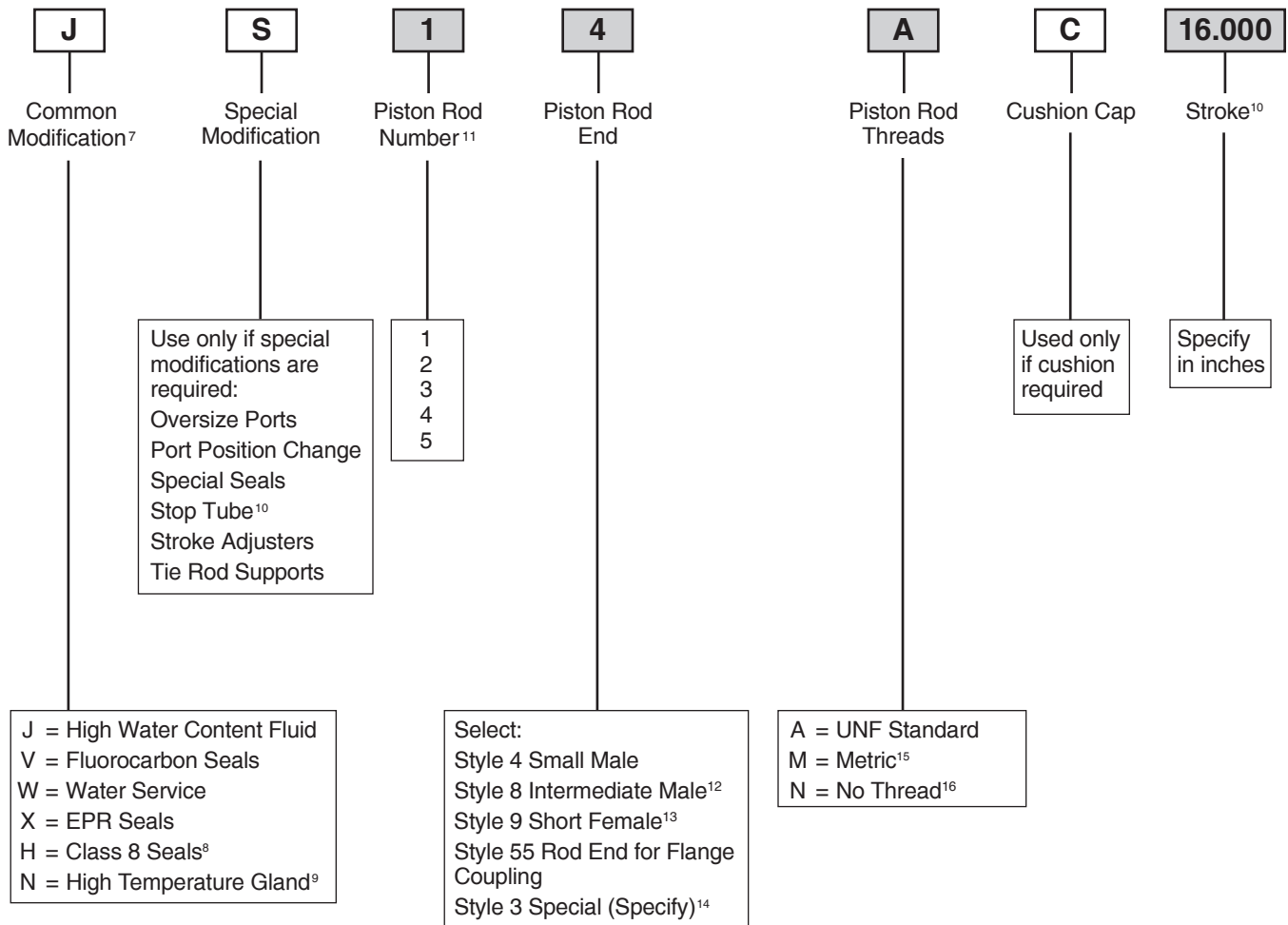

Shaded boxes identify required model number fields.

⁷ See common modifications Section D for additional options.

⁸ Class 8 seal option limited to 7.00" & 8.00" bore cylinders.

⁹ Energized PTFE rod seals & wiperseal are limited to rod sizes of 5.500" and smaller in 7.00" & 8.00" bore size. All other cylinder seals are fluorocarbon.

¹⁰ S = Stop Tube. Specify: stop tube length, net stroke and gross stroke. Gross stroke = stop tube length + net stroke. Gross stroke to be placed in the model number field.

Example:

2.000 inches long stop tube

+14.000 inches net stroke

16.000 inches gross stroke

¹¹ Refer to Rod buckling chart in Section E to assure rod number selected will not buckle under load.

¹² Style 8 intermediate male not available 10.00" - 20.00" bore.

¹³ Style 9 stroke restrictions may apply. See Style 9 minimum stroke table for details.

¹⁴ Provide dimensions for KK, A, W or WF. If otherwise special, furnish dimensioned sketch.

¹⁵ See Section D for detailed information regarding standard metric rod end thread sizes.

¹⁶ Must be specified for Piston Rod End Style 55.

Style 9 Minimum Stroke Table

Bore Ø	Rod Ø	Minimum Stroke
7.00	3.000	1.250
	3.500	1.500
	4.000	1.500
	4.500	2.500
	5.000	3.125
8.00	3.500	1.500
	4.000	1.500
	4.500	2.375
	5.000	2.875
	5.500	3.625
10.00	4.500	1.125
	5.000	1.375
	5.500	2.000
	7.000	3.125

Bore Ø	Rod Ø	Minimum Stroke
12.00	5.500	1.250
	7.000	2.375
	8.000	3.125
14.00	7.000	2.000
	8.000	2.750
	10.000	4.250
16.00	8.000	1.750
	9.000	2.500
	10.000	3.250
18.00	9.000	1.500
	10.000	2.250
20.00	10.000	1.250



Rod End Dimensions – 7.00" and 8.00" Bore

**Thread Style 4 (NFPA Style SM)
Small Male**

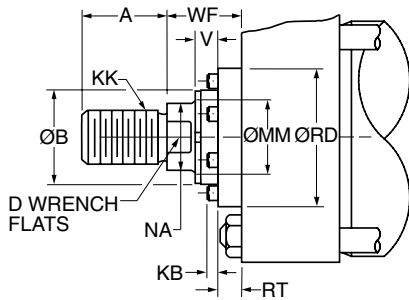

**Thread Style 8 (NFPA Style IM)
Intermediate Male**

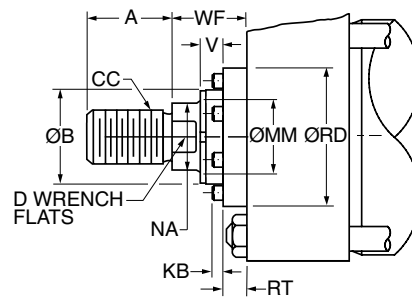

**Thread Style 9² (NFPA Style SF)
Small Female**

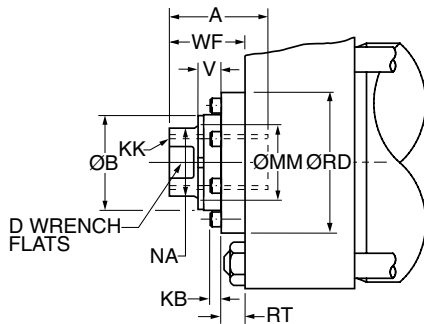

Thread Style 55¹

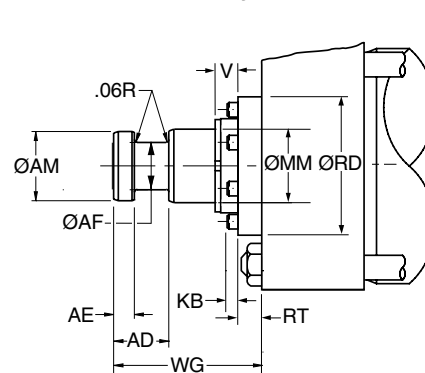

Rod End Dimensions – 7.00" & 8.00" Bore

Bore Ø	Rod No.	MM Rod Ø	Thread		Rod Extensions and Pilot Dimensions								
			Style 8 CC	Style 4 & 9 KK	A	B Ø +.000 -0.002	D	KB	NA	V	RD Ø	RT	WF
7.00	1 (std.)	3.000	2 3/4-12	2 1/4-12	3.50	3.749	2.63	0.250	2.88	0.63	5.25	0.63	2.25
	2	5.000	4 3/4-12	3 1/2-12	5.00	5.749	⁻³	0.000	4.88	0.25	7.25	1.00	2.25
	3	3.500	3 1/4-12	2 1/2-12	3.50	4.249	3.00	0.250	3.38	0.63	5.75	0.63	2.25
	4	4.000	3 3/4-12	3-12	4.00	4.749	3.38	0.250	3.88	0.50	6.50	0.75	2.25
	5	4.500	4 1/4-12	3 1/4-12	4.50	5.249	⁻³	0.250	4.38	0.50	7.00	0.75	2.25
8.00	1 (std.)	3.500	3 1/4-12	2 1/2-12	3.50	4.249	3.00	0.250	3.38	0.63	5.75	0.63	2.25
	2	5.500	5 1/4-12	4-12	5.50	6.249	⁻³	0.000	5.38	0.25	8.25	1.00	2.25
	3	4.000	3 3/4-12	3-12	4.00	4.749	3.38	0.250	3.88	0.50	6.50	0.75	2.25
	4	4.500	4 1/4-12	3 1/4-12	4.50	5.249	⁻³	0.250	4.38	0.50	7.00	0.75	2.25
	5	5.000	4 3/4-12	3 1/2-12	5.00	5.749	⁻³	0.000	4.88	0.25	7.25	1.00	2.25

“Special” Thread Style 3

Special thread, extension, rod eye, blank, etc., are also available.

To order, specify “Style 3” and give desired dimensions for KK, A, W or WF. If otherwise special, furnish dimensioned sketch.

¹ For special WG dimension, specify “Style 3” and give desired dimension for WG. For other changes, place “S” in the model code, and describe rod end with dimensioned sketch.

² Style 9 stroke restrictions may apply. See Style 9 Minimum Stroke Table on How to Order page for details.

³ These piston rod numbers will have 4 spanner wrench holes instead of wrench flats. See rod drawings on next page for dimensions.

Style 55 Rod End

MM Rod Ø	AD	AE +.001 -0.001	AF Ø	AM Ø	WG ¹
3.000	2.44	0.874	2.25	2.95	4.88
3.500	2.69	0.999	2.50	3.45	5.63
4.000	2.69	0.999	3.00	3.95	5.75
4.500	3.19	1.499	3.50	4.45	6.50
5.000	3.19	1.499	3.88	4.95	6.63
5.500	3.94	1.874	4.38	5.45	7.50

Rod End Dimensions – 10.00" - 20.00" Bore

**Thread Style 4 (NFPA Style SM)
Small Male**

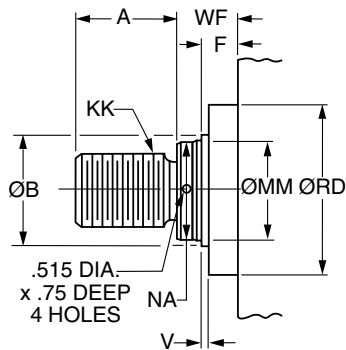

**Thread Style 55¹
Flanged Rod End**

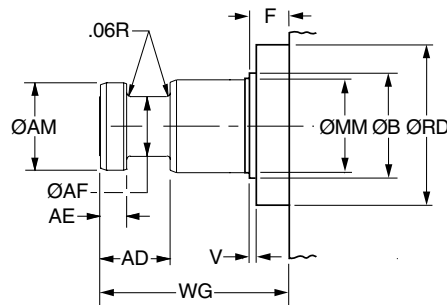

**Thread Style 9² (NFPA Style SF)
Small Female**

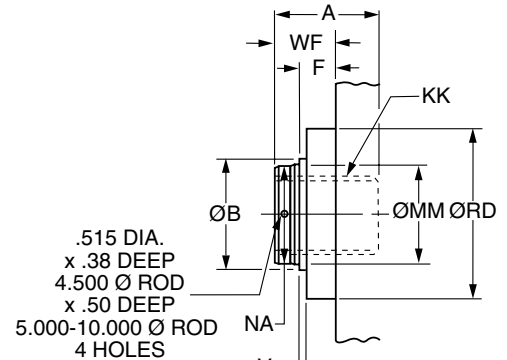

Rod End Dimensions – 10.00" - 20.00" Bore

Bore Ø	Rod No.	MM Rod Ø	Thread Style 4 & 9 KK	Rod Extensions and Pilot Dimensions						
				A	B Ø +.000 - .005	F	NA	RD	V	WF
10.00	1 (std.)	4.500	3 1/4-12	4.50	5.249	1.94	4.38	8.25	0.25	2.94
	2	7.000	5-12	7.00	7.999	1.94	6.88	10.50	0.38	3.50
	3	5.000	3 1/2-12	5.00	5.749	1.94	4.88	8.88	0.25	3.19
	4	5.500	4-12	5.50	6.249	1.94	5.38	9.38	0.25	3.19
12.00	1 (std.)	5.500	4-12	5.50	6.249	1.94	5.38	9.38	0.25	3.19
	2	8.000	5 3/4-12	8.00	8.999	1.94	7.88	12.50	0.38	4.00
	3	7.000	5-12	7.00	7.999	1.94	6.88	10.50	0.38	3.50
14.00	1 (std.)	7.000	5-12	7.00	7.999	1.94	6.88	10.50	0.38	3.50
	2	10.000	7 1/4-12	10.00	10.999	1.94	9.88	14.50	0.38	4.50
	3	8.000	5 3/4-12	8.00	8.999	1.94	7.88	12.50	0.38	4.00
16.00	1	8.000	5 3/4-12	8.00	8.999	1.94	7.88	12.50	0.38	4.00
	3	9.000	6 1/2-12	9.00	9.999	1.94	8.88	13.50	0.38	4.25
	4	10.000	7 1/4-12	10.00	10.999	1.94	9.88	14.50	0.38	4.50
18.00	1	9.000	6 1/2-12	9.00	9.999	1.94	8.88	13.50	0.38	4.25
	3	10.000	7 1/4-12	10.00	10.999	1.94	9.88	14.50	0.38	4.50
20.00	1	10.000	7 1/4-12	10.00	10.999	1.94	9.88	14.50	0.38	4.50

“Special” Thread Style 3

Special thread, extension, rod eye, blank, etc., are also available.

To order, specify “Style 3” and give desired dimensions for KK, A & WF. If otherwise special, furnish dimensioned sketch.

¹ For special WG dimension, specify “Style 3” and give desired dimension for WG. For other changes, place “S” in the model code, and describe rod end with dimensioned sketch.

² Style 9 stroke restrictions may apply. See Style 9 Minimum Stroke Table on How to Order page for details.

Style 55 Rod End

MM Rod Ø	AD	AE +.001 - .001	AF Ø	AM Ø	WG ¹
4.500	3.19	1.499	3.50	4.45	6.50
5.000	3.19	1.499	3.88	4.95	6.63
5.500	3.94	1.874	4.38	5.45	7.50
7.000	4.06	1.999	5.75	6.95	8.44
8.000	4.06	1.999	6.50	7.95	8.69
9.000	4.63	2.374	7.25	8.95	8.75
10.000	4.63	2.374	8.00	9.95	9.75



Mounting Information – 7.00" and 8.00" Bore Series 3H

Tie Rods Extended Both Ends

Style TD
(NFFPA Style MX1)

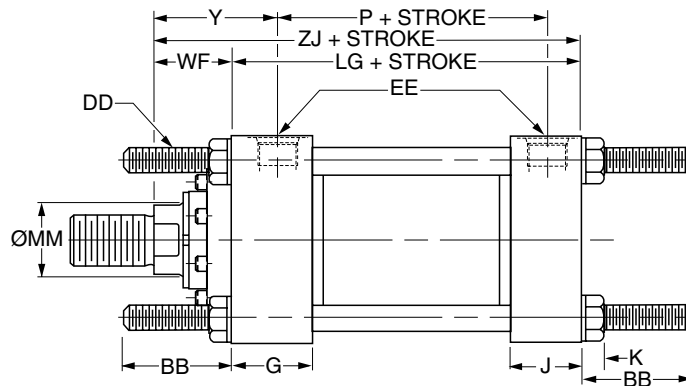
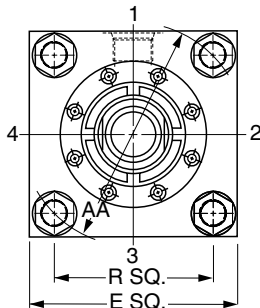
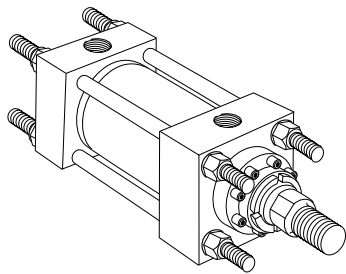

Basic Mounting (T) – NFFPA MXO – Not shown is no tie rod extended and can be supplied upon request.

Style TD – Dimensional and Mounting Data

Bore Ø	Rod No.	MM Rod Ø	AA	BB	DD	E	EE		G	J	K	R	WF	Y	Add Stroke		
							NPTF ¹	SAE ²							LG	P	ZJ
7.00	1 (std.)	3.000	9.31	4.13	1 1/8-12	8.50	1 1/4	20	2.75	2.75	1.16	6.58	2.25	3.69	8.50	5.63	10.75
	2	5.000	9.31	4.13	1 1/8-12	8.50	1 1/4	20	2.75	2.75	1.16	6.58	2.25	3.69	8.50	5.63	10.75
	3	3.500	9.31	4.13	1 1/8-12	8.50	1 1/4	20	2.75	2.75	1.16	6.58	2.25	3.69	8.50	5.63	10.75
	4	4.000	9.31	4.13	1 1/8-12	8.50	1 1/4	20	2.75	2.75	1.16	6.58	2.25	3.69	8.50	5.63	10.75
	5	4.500	9.31	4.13	1 1/8-12	8.50	1 1/4	20	2.75	2.75	1.16	6.58	2.25	3.69	8.50	5.63	10.75
8.00	1 (std.)	3.500	10.61	4.50	1 1/4-12	9.50	1 1/2	24	3.00	3.00	1.28	7.50	2.25	3.81	9.50	6.38	11.75
	2	5.500	10.61	4.50	1 1/4-12	9.50	1 1/2	24	3.00	3.00	1.28	7.50	2.25	3.81	9.50	6.38	11.75
	3	4.000	10.61	4.50	1 1/4-12	9.50	1 1/2	24	3.00	3.00	1.28	7.50	2.25	3.81	9.50	6.38	11.75
	4	4.500	10.61	4.50	1 1/4-12	9.50	1 1/2	24	3.00	3.00	1.28	7.50	2.25	3.81	9.50	6.38	11.75
	5	5.000	10.61	4.50	1 1/4-12	9.50	1 1/2	24	3.00	3.00	1.28	7.50	2.25	3.81	9.50	6.38	11.75

¹NPTF ports are available at no extra charge.

²SAE straight thread ports are standard and are indicated by port number.

Style TB

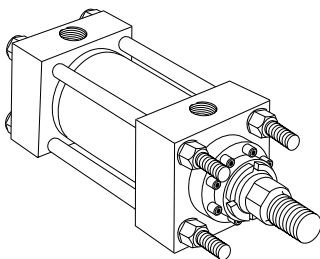

Style TC

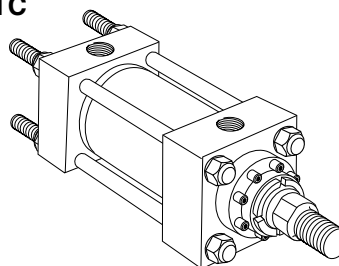

Dimensions for TB and TC Mount may be obtained from the above dimensional table.

Mounting Information – 7.00" and 8.00" Bore Series 3H

Cap Rectangular Flange Mounting
 Style H
 (NFPA Style MF2)

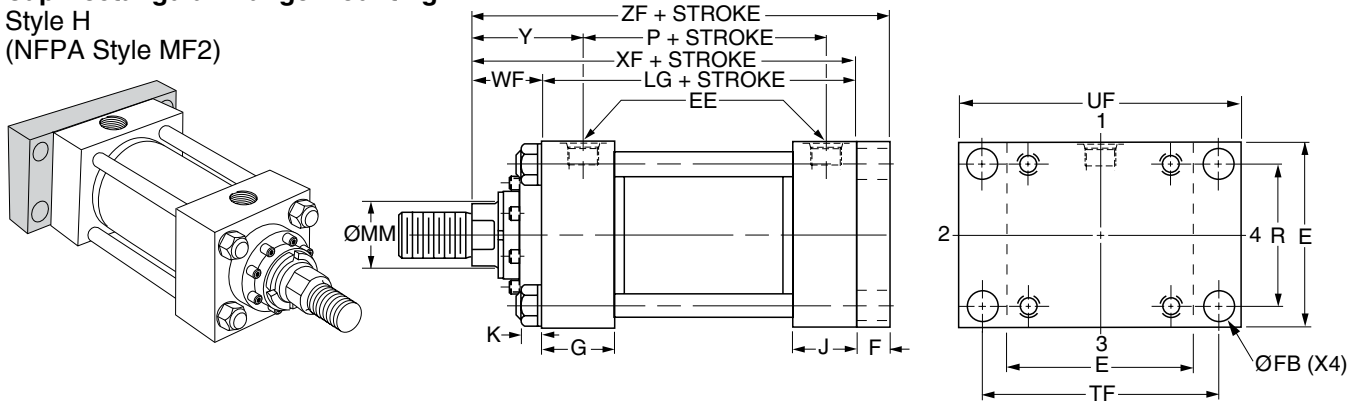

Style H – Dimensional and Mounting Data

Bore Ø	Rod No.	MM Rod Ø	E	EE		F	FB Ø	G	J	K	R	TF	UF	WF	Y	Add Stroke			
				NPTF ¹	SAE ²											LG	P	XF	ZF
7.00	1 (std.)	3.000	8.50	1 1/4	20	1.00	1.19	2.75	2.75	1.16	6.58	10.63	12.63	2.25	3.69	8.50	5.63	10.75	11.75
	2	5.000	8.50	1 1/4	20	1.00	1.19	2.75	2.75	1.16	6.58	10.63	12.63	2.25	3.69	8.50	5.63	10.75	11.75
	3	3.500	8.50	1 1/4	20	1.00	1.19	2.75	2.75	1.16	6.58	10.63	12.63	2.25	3.69	8.50	5.63	10.75	11.75
	4	4.000	8.50	1 1/4	20	1.00	1.19	2.75	2.75	1.16	6.58	10.63	12.63	2.25	3.69	8.50	5.63	10.75	11.75
	5	4.500	8.50	1 1/4	20	1.00	1.19	2.75	2.75	1.16	6.58	10.63	12.63	2.25	3.69	8.50	5.63	10.75	11.75
8.00	1 (std.)	3.500	9.50	1 1/2	24	1.00	1.31	3.00	3.00	1.28	7.50	11.81	14.00	2.25	3.81	9.50	6.38	11.75	12.75
	2	5.500	9.50	1 1/2	24	1.00	1.31	3.00	3.00	1.28	7.50	11.81	14.00	2.25	3.81	9.50	6.38	11.75	12.75
	3	4.000	9.50	1 1/2	24	1.00	1.31	3.00	3.00	1.28	7.50	11.81	14.00	2.25	3.81	9.50	6.38	11.75	12.75
	4	4.500	9.50	1 1/2	24	1.00	1.31	3.00	3.00	1.28	7.50	11.81	14.00	2.25	3.81	9.50	6.38	11.75	12.75
	5	5.000	9.50	1 1/2	24	1.00	1.31	3.00	3.00	1.28	7.50	11.81	14.00	2.25	3.81	9.50	6.38	11.75	12.75

¹NPTF ports are available at no extra charge.

²SAE straight thread ports are standard and are indicated by port number.

Style H – Maximum Operating Pressure / 3H & 3HD

Bore Ø	Max. psi Pull ³				
	Rod Code				
	1	2	3	4	5
7.00	2000	3000	2000	2500	2800
8.00	1700	2500	1700	1800	2200

³Maximum pressure rating – pull application.



Mounting Information – 7.00" and 8.00" Bore Series 3H

Cap Square Flange Mounting
Style HB
(NFPA Style MF6)

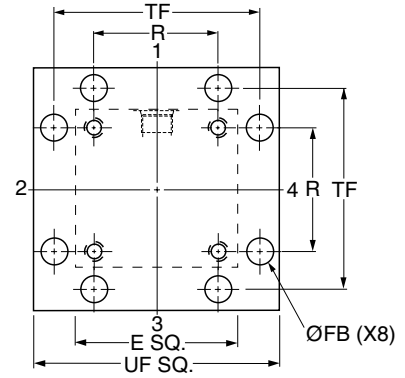
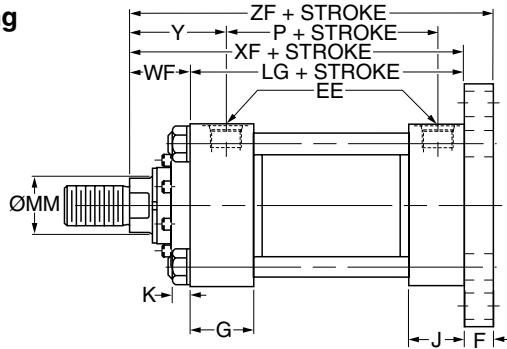
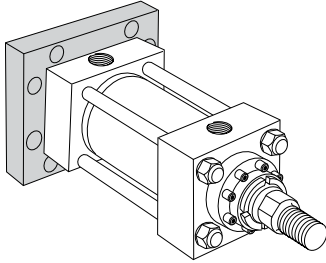

Style HB – Dimensional and Mounting Data

Bore Ø	Rod No.	MM Rod Ø	E	EE		F	FB Ø	G	J	K	R	TF	UF	WF	Y	Add Stroke			
				NPTF ¹	SAE ²											LG	P	XF	ZF
7.00	1 (std.)	3.000	8.50	1 1/4	20	1.00	1.19	2.75	2.75	1.16	6.58	10.63	12.63	2.25	3.69	8.50	5.63	10.75	11.75
	2	5.000	8.50	1 1/4	20	1.00	1.19	2.75	2.75	1.16	6.58	10.63	12.63	2.25	3.69	8.50	5.63	10.75	11.75
	3	3.500	8.50	1 1/4	20	1.00	1.19	2.75	2.75	1.16	6.58	10.63	12.63	2.25	3.69	8.50	5.63	10.75	11.75
	4	4.000	8.50	1 1/4	20	1.00	1.19	2.75	2.75	1.16	6.58	10.63	12.63	2.25	3.69	8.50	5.63	10.75	11.75
	5	4.500	8.50	1 1/4	20	1.00	1.19	2.75	2.75	1.16	6.58	10.63	12.63	2.25	3.69	8.50	5.63	10.75	11.75
8.00	1 (std.)	3.500	9.50	1 1/2	24	1.00	1.31	3.00	3.00	1.28	7.50	11.81	14.00	2.25	3.81	9.50	6.38	11.75	12.75
	2	5.500	9.50	1 1/2	24	1.00	1.31	3.00	3.00	1.28	7.50	11.81	14.00	2.25	3.81	9.50	6.38	11.75	12.75
	3	4.000	9.50	1 1/2	24	1.00	1.31	3.00	3.00	1.28	7.50	11.81	14.00	2.25	3.81	9.50	6.38	11.75	12.75
	4	4.500	9.50	1 1/2	24	1.00	1.31	3.00	3.00	1.28	7.50	11.81	14.00	2.25	3.81	9.50	6.38	11.75	12.75
	5	5.000	9.50	1 1/2	24	1.00	1.31	3.00	3.00	1.28	7.50	11.81	14.00	2.25	3.81	9.50	6.38	11.75	12.75

¹NPTF ports are available at no extra charge.

²SAE straight thread ports are standard and are indicated by port number.

Cap Rectangular Mounting
Style HH
(NFPA Style ME6)

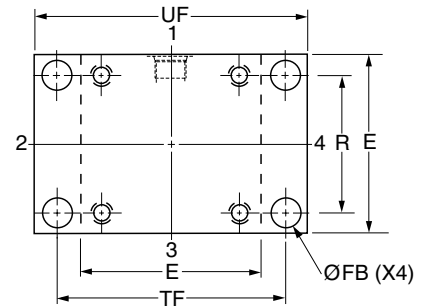
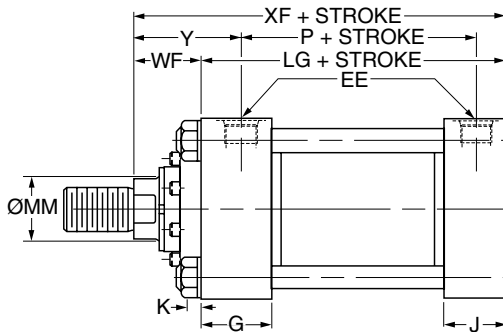
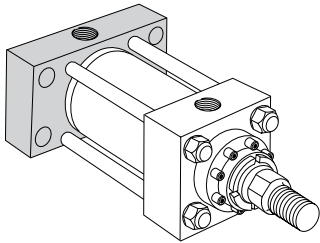

Style HH – Dimensional and Mounting Data

Bore Ø	Rod No.	MM Rod Ø	E	EE		FB Ø	G	J	K	R	TF	UF	WF	Y	Add Stroke		
				NPTF ¹	SAE ²										LG	P	XF
7.00	1 (std.)	3.000	8.50	1 1/4	20	1.19	2.75	2.75	1.16	6.58	10.63	12.63	2.25	3.69	8.50	5.63	10.75
	2	5.000	8.50	1 1/4	20	1.19	2.75	2.75	1.16	6.58	10.63	12.63	2.25	3.69	8.50	5.63	10.75
	3	3.500	8.50	1 1/4	20	1.19	2.75	2.75	1.16	6.58	10.63	12.63	2.25	3.69	8.50	5.63	10.75
	4	4.000	8.50	1 1/4	20	1.19	2.75	2.75	1.16	6.58	10.63	12.63	2.25	3.69	8.50	5.63	10.75
	5	4.500	8.50	1 1/4	20	1.19	2.75	2.75	1.16	6.58	10.63	12.63	2.25	3.69	8.50	5.63	10.75
8.00	1 (std.)	3.500	9.50	1 1/2	24	1.31	3.00	3.00	1.28	7.50	11.81	14.00	2.25	3.81	9.50	6.38	11.75
	2	5.500	9.50	1 1/2	24	1.31	3.00	3.00	1.28	7.50	11.81	14.00	2.25	3.81	9.50	6.38	11.75
	3	4.000	9.50	1 1/2	24	1.31	3.00	3.00	1.28	7.50	11.81	14.00	2.25	3.81	9.50	6.38	11.75
	4	4.500	9.50	1 1/2	24	1.31	3.00	3.00	1.28	7.50	11.81	14.00	2.25	3.81	9.50	6.38	11.75
	5	5.000	9.50	1 1/2	24	1.31	3.00	3.00	1.28	7.50	11.81	14.00	2.25	3.81	9.50	6.38	11.75

¹NPTF ports are available at no extra charge.

²SAE straight thread ports are standard and are indicated by port number.

Mounting Information – 7.00" and 8.00" Bore Series 3H

Head Rectangular Flange Mounting

Style J
(NFPA Style MF1)

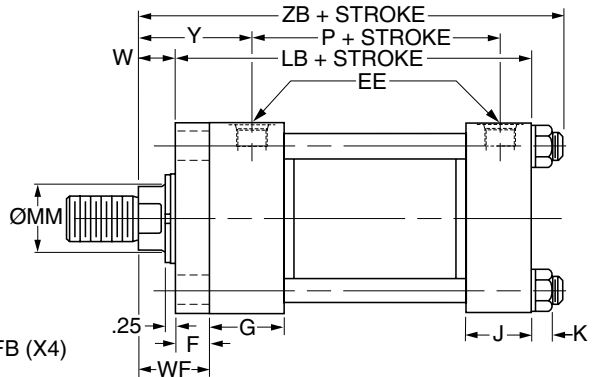
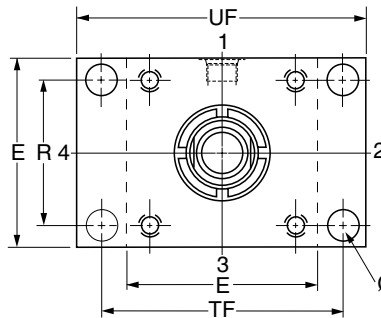
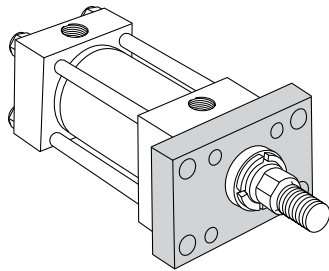

Style J – Dimensional and Mounting Data

For pressures exceeding those shown use mounting styles JB or JJ.

Bore Ø	Rod No.	MM Rod Ø	E	EE		F	FB Ø	G	J	K	R	TF	UF	W	WF	Y	Add Stroke		
				NPTF ¹	SAE ²												LB	P	ZB Max.
7.00	1 (std.)	3.000	8.50	1 1/4	20	1.00	1.19	2.75	2.75	1.16	6.58	10.63	12.63	1.25	2.25	3.69	9.50	5.63	12.31
	2	5.000	8.50	1 1/4	20	1.00	1.19	2.75	2.75	1.16	6.58	10.63	12.63	1.25	2.25	3.69	9.50	5.63	12.31
	3	3.500	8.50	1 1/4	20	1.00	1.19	2.75	2.75	1.16	6.58	10.63	12.63	1.25	2.25	3.69	9.50	5.63	12.31
	4	4.000	8.50	1 1/4	20	1.00	1.19	2.75	2.75	1.16	6.58	10.63	12.63	1.25	2.25	3.69	9.50	5.63	12.31
	5	4.500	8.50	1 1/4	20	1.00	1.19	2.75	2.75	1.16	6.58	10.63	12.63	1.25	2.25	3.69	9.50	5.63	12.31
8.00	1 (std.)	3.500	9.50	1 1/2	24	1.00	1.31	3.00	3.00	1.28	7.50	11.81	14.00	1.25	2.25	3.81	10.50	6.38	13.56
	2	5.500	9.50	1 1/2	24	1.00	1.31	3.00	3.00	1.28	7.50	11.81	14.00	1.25	2.25	3.81	10.50	6.38	13.56
	3	4.000	9.50	1 1/2	24	1.00	1.31	3.00	3.00	1.28	7.50	11.81	14.00	1.25	2.25	3.81	10.50	6.38	13.56
	4	4.500	9.50	1 1/2	24	1.00	1.31	3.00	3.00	1.28	7.50	11.81	14.00	1.25	2.25	3.81	10.50	6.38	13.56
	5	5.000	9.50	1 1/2	24	1.00	1.31	3.00	3.00	1.28	7.50	11.81	14.00	1.25	2.25	3.81	10.50	6.38	13.56

¹NPTF ports are available at no extra charge.

²SAE straight thread ports are standard and are indicated by port number.

Style J – Maximum Operating Pressure / 3H

Bore Ø	Max. psi Push ³				
	Rod Code				
	1	2	3	4	5
7.00	1400	800	1200	1100	1000
8.00	1100	800	1000	1000	800

³Maximum pressure rating – push application.

Style J – Maximum Operating Pressure / 3HD

Bore Ø	Max. psi Push ³				
	Rod Code				
	1	2	3	4	5
7.00	1000	400	800	400	400
8.00	800	400	700	400	400

³Maximum pressure rating – push application.



Mounting Information – 7.00" and 8.00" Bore Series 3H

Head Square Flange Mounting
Style JB
 (NFPA Style MF5)

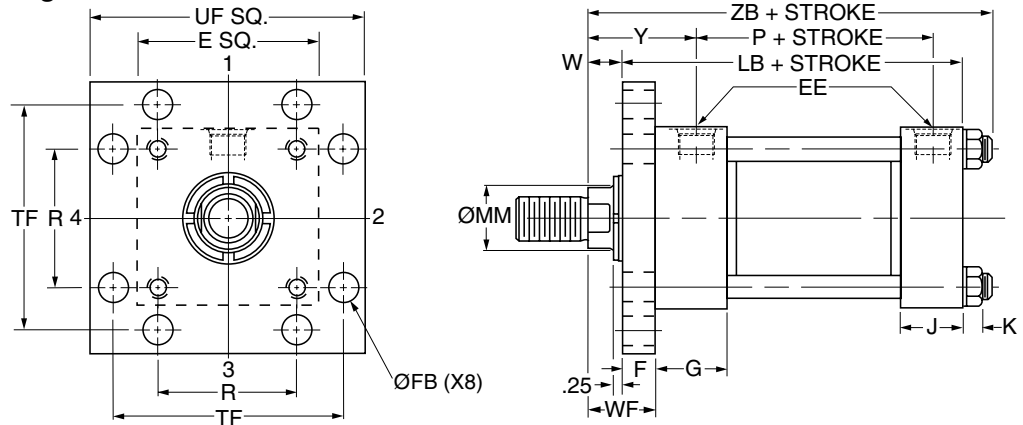
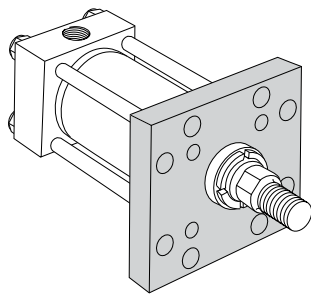

Style JB – Dimensional and Mounting Data

Bore Ø	Rod No.	MM Rod Ø	E	EE		F	FB Ø	G	J	K	R	TF	UF	W	WF	Y	Add Stroke		
				NPTF ¹	SAE ²												LB	P	ZB Max.
7.00	1 (std.)	3.000	8.50	1 1/4	20	1.00	1.19	2.75	2.75	1.16	6.58	10.63	12.63	1.25	2.25	3.69	9.50	5.63	12.31
	2	5.000	8.50	1 1/4	20	1.00	1.19	2.75	2.75	1.16	6.58	10.63	12.63	1.25	2.25	3.69	9.50	5.63	12.31
	3	3.500	8.50	1 1/4	20	1.00	1.19	2.75	2.75	1.16	6.58	10.63	12.63	1.25	2.25	3.69	9.50	5.63	12.31
	4	4.000	8.50	1 1/4	20	1.00	1.19	2.75	2.75	1.16	6.58	10.63	12.63	1.25	2.25	3.69	9.50	5.63	12.31
	5	4.500	8.50	1 1/4	20	1.00	1.19	2.75	2.75	1.16	6.58	10.63	12.63	1.25	2.25	3.69	9.50	5.63	12.31
8.00	1 (std.)	3.500	9.50	1 1/2	24	1.00	1.31	3.00	3.00	1.28	7.50	11.81	14.00	1.25	2.25	3.81	10.50	6.38	13.56
	2	5.500	9.50	1 1/2	24	1.00	1.31	3.00	3.00	1.28	7.50	11.81	14.00	1.25	2.25	3.81	10.50	6.38	13.56
	3	4.000	9.50	1 1/2	24	1.00	1.31	3.00	3.00	1.28	7.50	11.81	14.00	1.25	2.25	3.81	10.50	6.38	13.56
	4	4.500	9.50	1 1/2	24	1.00	1.31	3.00	3.00	1.28	7.50	11.81	14.00	1.25	2.25	3.81	10.50	6.38	13.56
	5	5.000	9.50	1 1/2	24	1.00	1.31	3.00	3.00	1.28	7.50	11.81	14.00	1.25	2.25	3.81	10.50	6.38	13.56

¹NPTF ports are available at no extra charge.

²SAE straight thread ports are standard and are indicated by port number.

Style JB – Maximum Operating Pressure / 3H

Bore Ø	Max. psi Push ³				
	Rod Code				
	1	2	3	4	5
7.00	3000	2700	3000	3000	3000
8.00	3000	2300	2500	2500	2500

³Maximum pressure rating – push application.

Style JB – Maximum Operating Pressure / 3HD

Bore Ø	Max. psi Push ³				
	Rod Code				
	1	2	3	4	5
7.00	2500	1500	2200	1500	1500
8.00	2000	1400	2000	1400	1400

³Maximum pressure rating – push application.

Mounting Information – 7.00" and 8.00" Bore Series 3H

Head Rectangular Mounting
 Style JJ
 (NFA Style ME5)

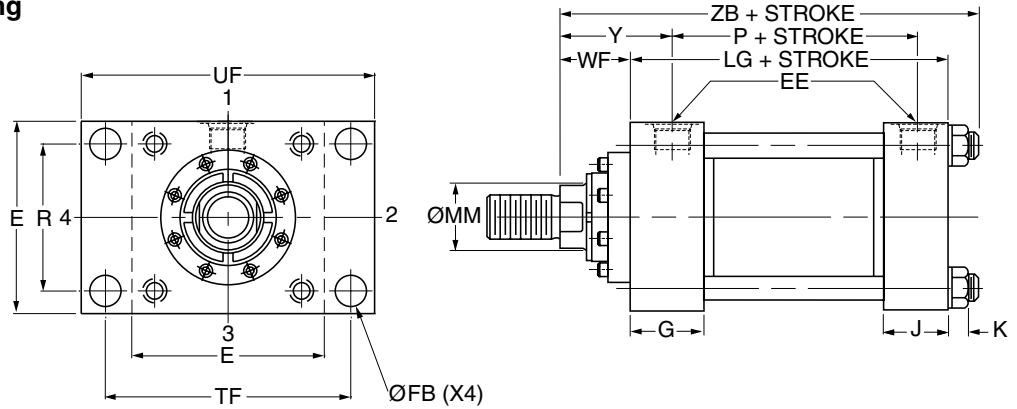
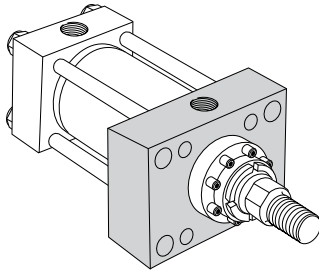

Style JJ – Dimensional and Mounting Data

Bore Ø	Rod No.	MM Rod Ø	E	EE		FB Ø	G	J	K	R	TF	UF	WF	Y	Add Stroke		
				NPTF ¹	SAE ²										LG	P	ZB Max.
7.00	1 (std.)	3.000	8.50	1 1/4	20	1.19	2.75	2.75	1.16	6.58	10.63	12.63	2.25	3.69	8.50	5.63	12.31
	2	5.000	8.50	1 1/4	20	1.19	2.75	2.75	1.16	6.58	10.63	12.63	2.25	3.69	8.50	5.63	12.31
	3	3.500	8.50	1 1/4	20	1.19	2.75	2.75	1.16	6.58	10.63	12.63	2.25	3.69	8.50	5.63	12.31
	4	4.000	8.50	1 1/4	20	1.19	2.75	2.75	1.16	6.58	10.63	12.63	2.25	3.69	8.50	5.63	12.31
	5	4.500	8.50	1 1/4	20	1.19	2.75	2.75	1.16	6.58	10.63	12.63	2.25	3.69	8.50	5.63	12.31
8.00	1 (std.)	3.500	9.50	1 1/2	24	1.31	3.00	3.00	1.28	7.50	11.81	14.00	2.25	3.81	9.50	6.38	13.56
	2	5.500	9.50	1 1/2	24	1.31	3.00	3.00	1.28	7.50	11.81	14.00	2.25	3.81	9.50	6.38	13.56
	3	4.000	9.50	1 1/2	24	1.31	3.00	3.00	1.28	7.50	11.81	14.00	2.25	3.81	9.50	6.38	13.56
	4	4.500	9.50	1 1/2	24	1.31	3.00	3.00	1.28	7.50	11.81	14.00	2.25	3.81	9.50	6.38	13.56
	5	5.000	9.50	1 1/2	24	1.31	3.00	3.00	1.28	7.50	11.81	14.00	2.25	3.81	9.50	6.38	13.56

¹NPTF ports are available at no extra charge.

²SAE straight thread ports are standard and are indicated by port number.



Mounting Information – 7.00" and 8.00" Bore Series 3H

**Side Lug Mounting
Style C
(NFPA Style MS2)**

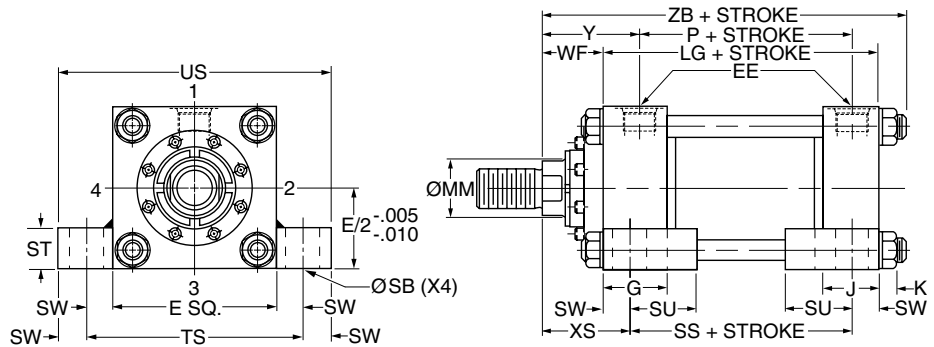
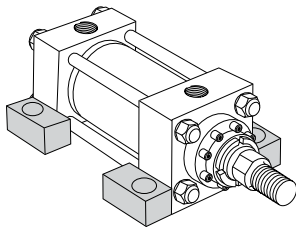

Style C – Dimensional and Mounting Data

Bore Ø	Rod No.	MM Rod Ø	E	EE		G	J	K	SB Ø	ST	SU	SW	TS	US	WF	XS	Y	Add Stroke			
				NPTF ¹	SAE ²													LG	P	SS	ZB Max.
7.00	1 (std.)	3.000	8.50	1 1/4	20	2.75	2.75	1.16	1.56	1.75	2.88	1.38	11.25	14.00	2.25	3.63	3.69	8.50	5.63	5.75	12.31
	2	5.000	8.50	1 1/4	20	2.75	2.75	1.16	1.56	1.75	2.88	1.38	11.25	14.00	2.25	3.63	3.69	8.50	5.63	5.75	12.31
	3	3.500	8.50	1 1/4	20	2.75	2.75	1.16	1.56	1.75	2.88	1.38	11.25	14.00	2.25	3.63	3.69	8.50	5.63	5.75	12.31
	4	4.000	8.50	1 1/4	20	2.75	2.75	1.16	1.56	1.75	2.88	1.38	11.25	14.00	2.25	3.63	3.69	8.50	5.63	5.75	12.31
	5	4.500	8.50	1 1/4	20	2.75	2.75	1.16	1.56	1.75	2.88	1.38	11.25	14.00	2.25	3.63	3.69	8.50	5.63	5.75	12.31
8.00	1 (std.)	3.500	9.50	1 1/2	24	3.00	3.00	1.28	1.56	1.75	2.88	1.38	12.25	15.00	2.25	3.63	3.81	9.50	6.38	6.75	13.56
	2	5.500	9.50	1 1/2	24	3.00	3.00	1.28	1.56	1.75	2.88	1.38	12.25	15.00	2.25	3.63	3.81	9.50	6.38	6.75	13.56
	3	4.000	9.50	1 1/2	24	3.00	3.00	1.28	1.56	1.75	2.88	1.38	12.25	15.00	2.25	3.63	3.81	9.50	6.38	6.75	13.56
	4	4.500	9.50	1 1/2	24	3.00	3.00	1.28	1.56	1.75	2.88	1.38	12.25	15.00	2.25	3.63	3.81	9.50	6.38	6.75	13.56
	5	5.000	9.50	1 1/2	24	3.00	3.00	1.28	1.56	1.75	2.88	1.38	12.25	15.00	2.25	3.63	3.81	9.50	6.38	6.75	13.56

¹NPTF ports are available at no extra charge.

²SAE straight thread ports are standard and are indicated by port number.

**Side Tapped Mounting
Style F
(NFPA Style MS4)**

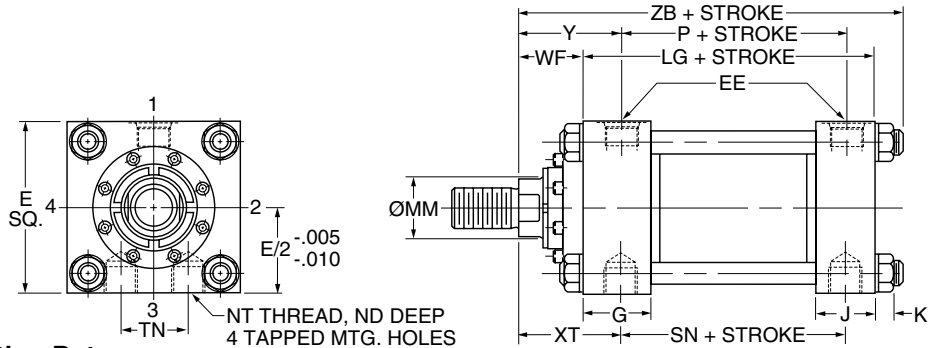
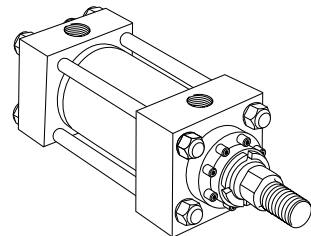

Style F – Dimensional and Mounting Data

Bore Ø	Rod No.	MM Rod Ø	E	EE		G	J	K	ND	NT	TN	WF	XT	Y	Add Stroke			
				NPTF ¹	SAE ²										LG	P	SN	ZB Max.
7.00	1 (std.)	3.000	8.50	1 1/4	20	2.75	2.75	1.16	1.13	1 1/2-6	3.75	2.25	3.81	3.69	8.50	5.63	5.88	12.31
	2	5.000	8.50	1 1/4	20	2.75	2.75	1.16	1.13	1 1/2-6	3.75	2.25	3.81	3.69	8.50	5.63	5.88	12.31
	3	3.500	8.50	1 1/4	20	2.75	2.75	1.16	1.13	1 1/2-6	3.75	2.25	3.81	3.69	8.50	5.63	5.88	12.31
	4	4.000	8.50	1 1/4	20	2.75	2.75	1.16	1.13	1 1/2-6	3.75	2.25	3.81	3.69	8.50	5.63	5.88	12.31
	5	4.500	8.50	1 1/4	20	2.75	2.75	1.16	1.13	1 1/2-6	3.75	2.25	3.81	3.69	8.50	5.63	5.88	12.31
8.00	1 (std.)	3.500	9.50	1 1/2	24	3.00	3.00	1.28	1.50	1 1/2-6	4.25	2.25	3.94	3.81	9.50	6.38	6.63	13.56
	2	5.500	9.50	1 1/2	24	3.00	3.00	1.28	1.50	1 1/2-6	4.25	2.25	3.94	3.81	9.50	6.38	6.63	13.56
	3	4.000	9.50	1 1/2	24	3.00	3.00	1.28	1.50	1 1/2-6	4.25	2.25	3.94	3.81	9.50	6.38	6.63	13.56
	4	4.500	9.50	1 1/2	24	3.00	3.00	1.28	1.50	1 1/2-6	4.25	2.25	3.94	3.81	9.50	6.38	6.63	13.56
	5	5.000	9.50	1 1/2	24	3.00	3.00	1.28	1.50	1 1/2-6	4.25	2.25	3.94	3.81	9.50	6.38	6.63	13.56

¹NPTF ports are available at no extra charge.

²SAE straight thread ports are standard and are indicated by port number.



Mounting Information – 7.00" and 8.00" Bore Series 3H

Cap Fixed Clevis Mounting
Style BB
(NFPA Style MP1)

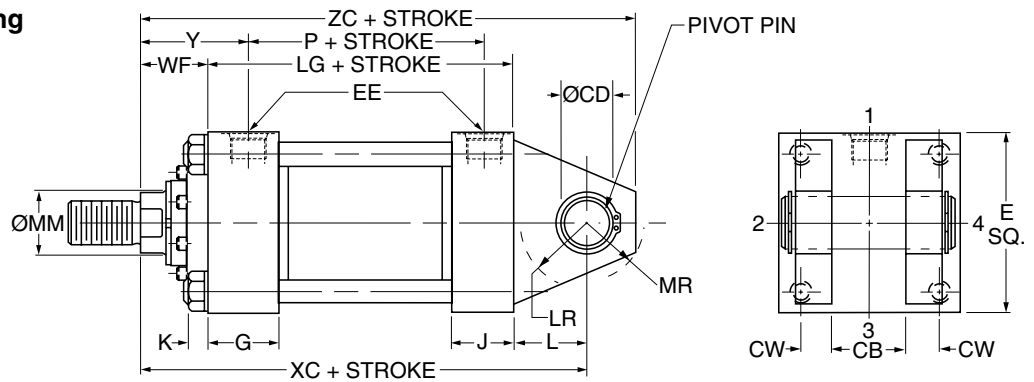
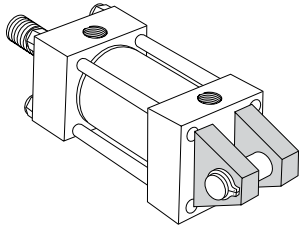

Style BB – Dimensional and Mounting Data

Bore Ø	Rod No.	MM Rod Ø	CB	CD ³ Ø +.000 -.002	CW	E	EE		G	J	K	L	LR	MR	WF	Y
							NPTF ¹	SAE ²								
7.00	1 (std.)	3.000	3.00	2.501	1.50	8.50	1 1/4	20	2.75	2.75	1.16	3.00	2.75	2.88	2.25	3.69
	2	5.000	3.00	2.501	1.50	8.50	1 1/4	20	2.75	2.75	1.16	3.00	2.75	2.88	2.25	3.69
	3	3.500	3.00	2.501	1.50	8.50	1 1/4	20	2.75	2.75	1.16	3.00	2.75	2.88	2.25	3.69
	4	4.000	3.00	2.501	1.50	8.50	1 1/4	20	2.75	2.75	1.16	3.00	2.75	2.88	2.25	3.69
	5	4.500	3.00	2.501	1.50	8.50	1 1/4	20	2.75	2.75	1.16	3.00	2.75	2.88	2.25	3.69
8.00	1 (std.)	3.500	3.00	3.001	1.50	9.50	1 1/2	24	3.00	3.00	1.28	3.25	3.25	3.13	2.25	3.81
	2	5.500	3.00	3.001	1.50	9.50	1 1/2	24	3.00	3.00	1.28	3.25	3.25	3.13	2.25	3.81
	3	4.000	3.00	3.001	1.50	9.50	1 1/2	24	3.00	3.00	1.28	3.25	3.25	3.13	2.25	3.81
	4	4.500	3.00	3.001	1.50	9.50	1 1/2	24	3.00	3.00	1.28	3.25	3.25	3.13	2.25	3.81
	5	5.000	3.00	3.001	1.50	9.50	1 1/2	24	3.00	3.00	1.28	3.25	3.25	3.13	2.25	3.81

¹NPTF ports are available at no extra charge.

²SAE straight thread ports are standard and are indicated by port number.

³Dimension CD is pin diameter.

Style BB – Dimensional and Mounting Data

Bore Ø	Rod No.	MM Rod Ø	WF	Add Stroke			
				LG	P	XC	ZC
7.00	1 (std.)	3.000	2.25	8.50	5.63	13.75	16.25
	2	5.000	2.25	8.50	5.63	13.75	16.25
	3	3.500	2.25	8.50	5.63	13.75	16.25
	4	4.000	2.25	8.50	5.63	13.75	16.25
	5	4.500	2.25	8.50	5.63	13.75	16.25
8.00	1 (std.)	3.500	2.25	9.50	6.38	15.00	17.75
	2	5.500	2.25	9.50	6.38	15.00	17.75
	3	4.000	2.25	9.50	6.38	15.00	17.75
	4	4.500	2.25	9.50	6.38	15.00	17.75
	5	5.000	2.25	9.50	6.38	15.00	17.75



Mounting Information – 7.00" and 8.00" Bore Series 3H

Head Trunnion Mounting

Style D

(NFA Style MT1)

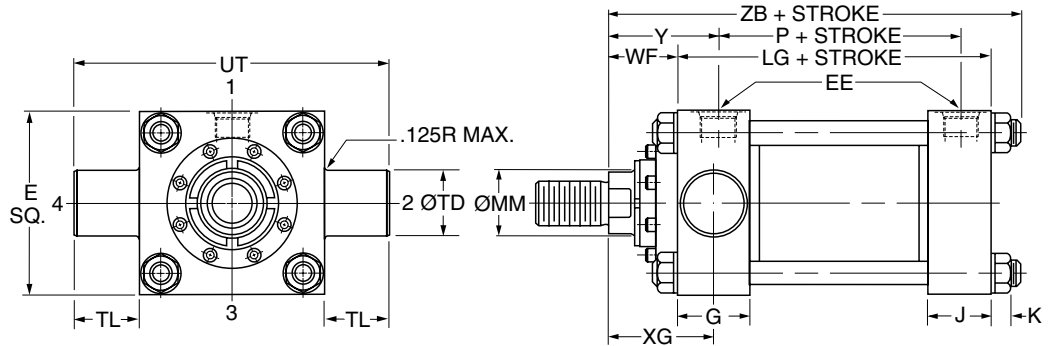
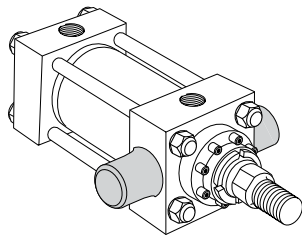

Style D – Dimensional and Mounting Data

Bore Ø	Rod No.	MM Rod Ø	E	EE		G	J	K	TD Ø +0.000 -0.002	TL	UT	WF	Y	XG
				NPTF ¹	SAE ²									
7.00	1 (std.)	3.000	8.50	1 1/4	20	2.75	2.75	1.16	2.500	2.50	13.50	2.25	3.69	3.63
	2	5.000	8.50	1 1/4	20	2.75	2.75	1.16	2.500	2.50	13.50	2.25	3.69	3.63
	3	3.500	8.50	1 1/4	20	2.75	2.75	1.16	2.500	2.50	13.50	2.25	3.69	3.63
	4	4.000	8.50	1 1/4	20	2.75	2.75	1.16	2.500	2.50	13.50	2.25	3.69	3.63
	5	4.500	8.50	1 1/4	20	2.75	2.75	1.16	2.500	2.50	13.50	2.25	3.69	3.63
8.00	1 (std.)	3.500	9.50	1 1/2	24	3.00	3.00	1.28	3.000	3.00	15.50	2.25	3.81	3.75
	2	5.500	9.50	1 1/2	24	3.00	3.00	1.28	3.000	3.00	15.50	2.25	3.81	3.75
	3	4.000	9.50	1 1/2	24	3.00	3.00	1.28	3.000	3.00	15.50	2.25	3.81	3.75
	4	4.500	9.50	1 1/2	24	3.00	3.00	1.28	3.000	3.00	15.50	2.25	3.81	3.75
	5	5.000	9.50	1 1/2	24	3.00	3.00	1.28	3.000	3.00	15.50	2.25	3.81	3.75

¹NPTF ports are available at no extra charge.

²SAE straight thread ports are standard and are indicated by port number.

Style D – Dimensional and Mounting Data

Bore Ø	Rod No.	MM Rod Ø	Add Stroke		
			LG	P	ZB Max.
7.00	1 (std.)	3.000	8.50	5.63	12.31
	2	5.000	8.50	5.63	12.31
	3	3.500	8.50	5.63	12.31
	4	4.000	8.50	5.63	12.31
	5	4.500	8.50	5.63	12.31
8.00	1 (std.)	3.500	9.50	6.38	13.56
	2	5.500	9.50	6.38	13.56
	3	4.000	9.50	6.38	13.56
	4	4.500	9.50	6.38	13.56
	5	5.000	9.50	6.38	13.56

Mounting Information – 7.00" and 8.00" Bore Series 3H

Cap Trunnion Mounting

Style DB
(NFPA Style MT2)

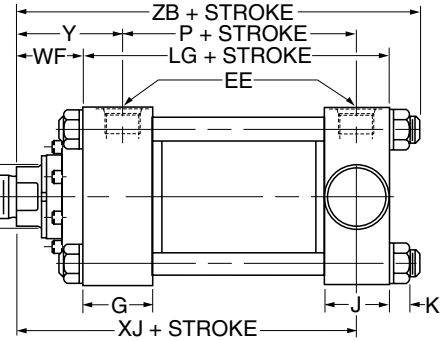
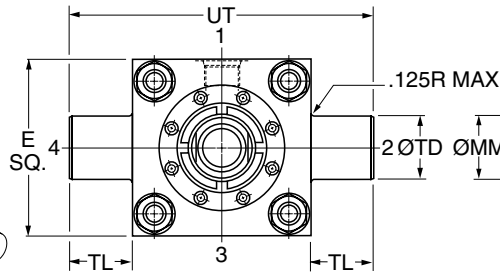
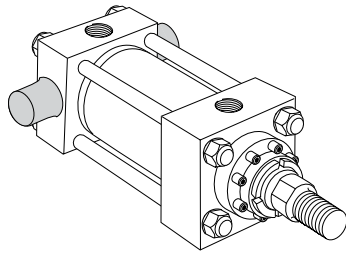

Style DB – Dimensional and Mounting Data

Bore Ø	Rod No.	MM Rod Ø	E	EE		G	J	K	TD Ø +0.000 -0.002	TL	UT	WF	Y
				NPTF ¹	SAE ²								
7.00	1 (std.)	3.000	8.50	1 1/4	20	2.75	2.75	1.16	2.500	2.50	13.50	2.25	3.69
	2	5.000	8.50	1 1/4	20	2.75	2.75	1.16	2.500	2.50	13.50	2.25	3.69
	3	3.500	8.50	1 1/4	20	2.75	2.75	1.16	2.500	2.50	13.50	2.25	3.69
	4	4.000	8.50	1 1/4	20	2.75	2.75	1.16	2.500	2.50	13.50	2.25	3.69
	5	4.500	8.50	1 1/4	20	2.75	2.75	1.16	2.500	2.50	13.50	2.25	3.69
8.00	1 (std.)	3.500	9.50	1 1/2	24	3.00	3.00	1.28	3.000	3.00	15.50	2.25	3.81
	2	5.500	9.50	1 1/2	24	3.00	3.00	1.28	3.000	3.00	15.50	2.25	3.81
	3	4.000	9.50	1 1/2	24	3.00	3.00	1.28	3.000	3.00	15.50	2.25	3.81
	4	4.500	9.50	1 1/2	24	3.00	3.00	1.28	3.000	3.00	15.50	2.25	3.81
	5	5.000	9.50	1 1/2	24	3.00	3.00	1.28	3.000	3.00	15.50	2.25	3.81

¹NPTF ports are available at no extra charge.

²SAE straight thread ports are standard and are indicated by port number.

Style DB – Dimensional and Mounting Data

Bore Ø	Rod No.	MM Rod Ø	Add Stroke			
			LG	P	XJ	ZB Max
7.00	1 (std.)	3.000	8.50	5.63	9.38	12.31
	2	5.000	8.50	5.63	9.38	12.31
	3	3.500	8.50	5.63	9.38	12.31
	4	4.000	8.50	5.63	9.38	12.31
	5	4.500	8.50	5.63	9.38	12.31
8.00	1 (std.)	3.500	9.50	6.38	10.25	13.56
	2	5.500	9.50	6.38	10.25	13.56
	3	4.000	9.50	6.38	10.25	13.56
	4	4.500	9.50	6.38	10.25	13.56
	5	5.000	9.50	6.38	10.25	13.56



Mounting Information – 7.00" and 8.00" Bore Series 3H

Intermediate Fixed Trunnion Mounting

Style DD

(NFPA Former Standard Style MT4)

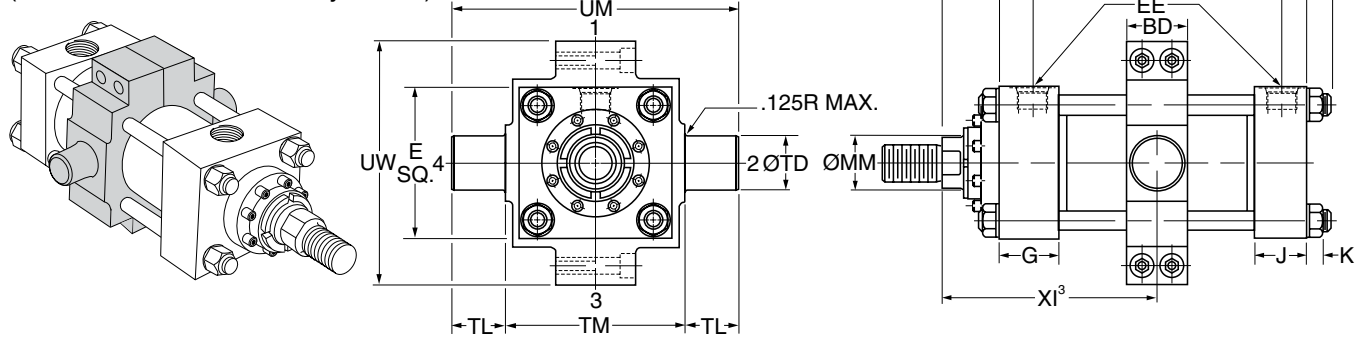

Style DD – Dimensional and Mounting Data

Bore Ø	Rod No.	MM Rod Ø	BD	E	EE		G	J	K	TD Ø +0.000 -0.002	TL	TM	UM	UW	WF	Y	Min. XI³
					NPTF¹	SAE²											
7.00	1 (std.)	3.000	3.00	8.50	1 1/4	20	2.75	2.75	1.16	2.500	2.50	9.75	14.75	11.50	2.25	3.69	6.56
	2	5.000	3.00	8.50	1 1/4	20	2.75	2.75	1.16	2.500	2.50	9.75	14.75	11.50	2.25	3.69	6.56
	3	3.500	3.00	8.50	1 1/4	20	2.75	2.75	1.16	2.500	2.50	9.75	14.75	11.50	2.25	3.69	6.56
	4	4.000	3.00	8.50	1 1/4	20	2.75	2.75	1.16	2.500	2.50	9.75	14.75	11.50	2.25	3.69	6.56
	5	4.500	3.00	8.50	1 1/4	20	2.75	2.75	1.16	2.500	2.50	9.75	14.75	11.50	2.25	3.69	6.56
8.00	1 (std.)	3.500	3.50	9.50	1 1/2	24	3.00	3.00	1.28	3.000	3.00	11.00	17.00	13.38	2.25	3.81	7.06
	2	5.500	3.50	9.50	1 1/2	24	3.00	3.00	1.28	3.000	3.00	11.00	17.00	13.38	2.25	3.81	7.06
	3	4.000	3.50	9.50	1 1/2	24	3.00	3.00	1.28	3.000	3.00	11.00	17.00	13.38	2.25	3.81	7.06
	4	4.500	3.50	9.50	1 1/2	24	3.00	3.00	1.28	3.000	3.00	11.00	17.00	13.38	2.25	3.81	7.06
	5	5.000	3.50	9.50	1 1/2	24	3.00	3.00	1.28	3.000	3.00	11.00	17.00	13.38	2.25	3.81	7.06

¹NPTF ports are available at no extra charge.

²SAE straight thread ports are standard and are indicated by port number.

³Dimension XI to be specified by customer.

Style DD – Dimensional and Mounting Data

Bore Ø	Rod No.	MM Rod Ø	Style DD Minimum Stroke	Add Stroke			
				LG	P	Max. XI⁴	ZB Max.
7.00	1 (std.)	3.000	0.13	8.50	5.63	6.44	12.31
	2	5.000	0.13	8.50	5.63	6.44	12.31
	3	3.500	0.13	8.50	5.63	6.44	12.31
	4	4.000	0.13	8.50	5.63	6.44	12.31
	5	4.500	0.13	8.50	5.63	6.44	12.31
8.00	1 (std.)	3.500	0.13	9.50	6.38	6.94	13.56
	2	5.500	0.13	9.50	6.38	6.94	13.56
	3	4.000	0.13	9.50	6.38	6.94	13.56
	4	4.500	0.13	9.50	6.38	6.94	13.56
	5	5.000	0.13	9.50	6.38	6.94	13.56

⁴Dimensions shown are valid for standard WF dimension.

Mounting Information – 7.00" and 8.00" Bore Series 3H

Heavy Duty Intermediate Fixed Trunnion Mounting

Style DE
(NFPA Current Standard Style MT4)

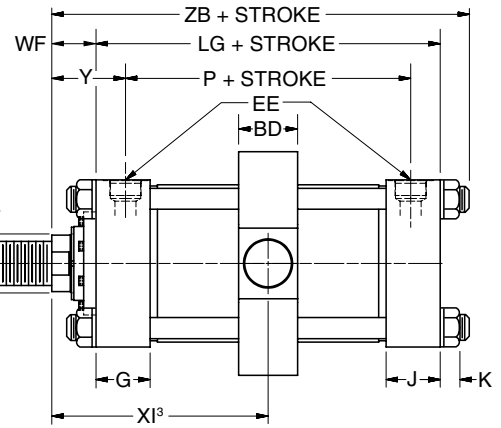
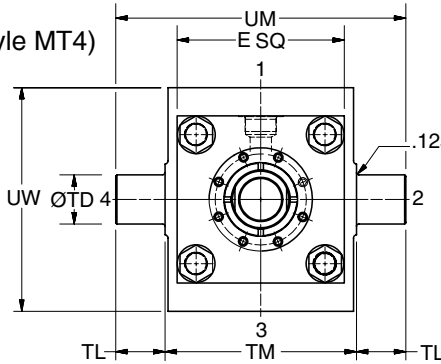
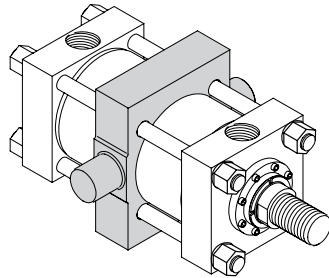

Style DE – Dimensional and Mounting Data

Bore Ø	Rod No.	MM Rod Ø	BD	E	EE		G	J	K	TD Ø +.000 -.002	TL	TM	UM	UW	WF	Y	Min XI ³
					NPTF ¹	SAE ²											
7.00	1 (std.)	3.000	4.000	8.50	1 1/4	20	2.75	2.75	1.16	3.500	2.50	9.75	14.75	11.38	2.25	3.69	7.06
	2	5.000	4.000	8.50	1 1/4	20	2.75	2.75	1.16	3.500	2.50	9.75	14.75	11.38	2.25	3.69	7.06
	3	3.500	4.000	8.50	1 1/4	20	2.75	2.75	1.16	3.500	2.50	9.75	14.75	11.38	2.25	3.69	7.06
	4	4.000	4.000	8.50	1 1/4	20	2.75	2.75	1.16	3.500	2.50	9.75	14.75	11.38	2.25	3.69	7.06
	5	4.500	4.000	8.50	1 1/4	20	2.75	2.75	1.16	3.500	2.50	9.75	14.75	11.38	2.25	3.69	7.06
8.00	1 (std.)	3.500	4.500	9.50	1 1/2	24	3.00	3.00	1.28	4.000	3.00	11.00	17.00	12.00	2.25	3.81	7.56
	2	5.500	4.500	9.50	1 1/2	24	3.00	3.00	1.28	4.000	3.00	11.00	17.00	12.00	2.25	3.81	7.56
	3	4.000	4.500	9.50	1 1/2	24	3.00	3.00	1.28	4.000	3.00	11.00	17.00	12.00	2.25	3.81	7.56
	4	4.500	4.500	9.50	1 1/2	24	3.00	3.00	1.28	4.000	3.00	11.00	17.00	12.00	2.25	3.81	7.56
	5	5.000	4.500	9.50	1 1/2	24	3.00	3.00	1.28	4.000	3.00	11.00	17.00	12.00	2.25	3.81	7.56

¹NPTF ports are available at no extra charge.

²SAE straight thread ports are standard and are indicated by port number.

³Dimension XI to be specified by customer.

Style DE – Dimensional and Mounting Data

Bore Ø	Rod No.	MM Rod Ø	Style DE Minimum Stroke	Add Stroke			
				LG	P	Max. XI ⁴	ZB Max.
7.00	1 (std.)	3.000	1.13	8.50	5.63	5.94	12.31
	2	5.000	1.13	8.50	5.63	5.94	12.31
	3	3.500	1.13	8.50	5.63	5.94	12.31
	4	4.000	1.13	8.50	5.63	5.94	12.31
	5	4.500	1.13	8.50	5.63	5.94	12.31
8.00	1 (std.)	3.500	1.13	9.50	6.38	6.44	13.56
	2	5.500	1.13	9.50	6.38	6.44	13.56
	3	4.000	1.13	9.50	6.38	6.44	13.56
	4	4.500	1.13	9.50	6.38	6.44	13.56
	5	5.000	1.13	9.50	6.38	6.44	13.56

⁴Dimensions shown are valid for standard WF dimension.



Double Rod Models – 7.00" and 8.00" Bore

Double Rod Cylinder
Style K

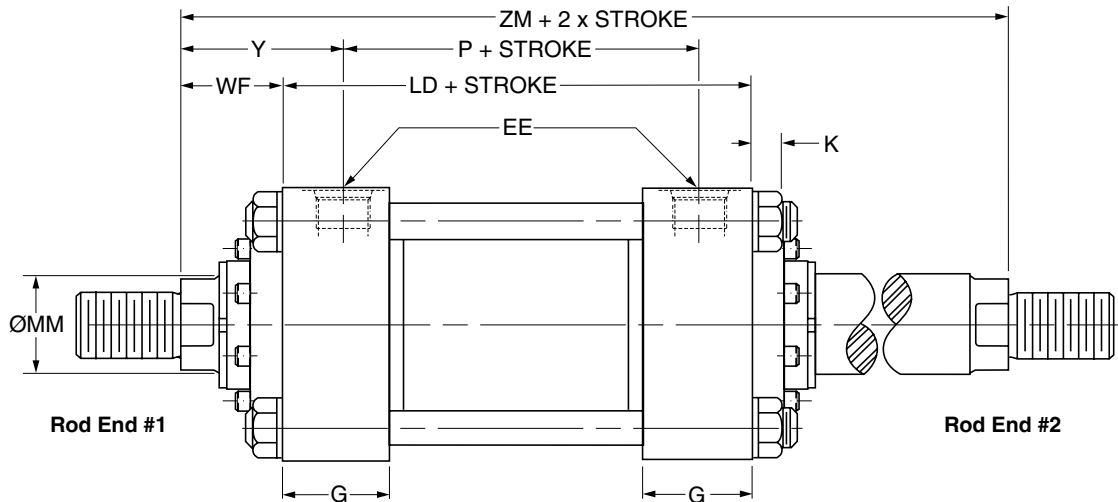

Mounting Styles for Single Rod Models	Mounting Styles for Corresponding Double Rod Models ¹	Dimensions Shown on This Page Supplement Dimensions on Pages Listed Below for 7.00" - 8.00" Bores
TB	KTB	40
TD	KTD	40
J	KJ	43
JB	KJB	44
JJ	KJJ	45
C	KC	46
F	KF	46
D	KD	48
DD	KDD ²	50
DE	KDE ²	51

¹ If only one end of these Double Rod Cylinders is to be cushioned, be sure to specify clearly which end this will be.

² Specify XI dimension from rod end #1.

Bore Ø	Rod No.	MM Rod Ø	WF	Add Stroke			Add 2X Stroke
				LD	SNK	SSK	ZM
7.00	1 (std.)	3.00	2.25	8.50	5.38	5.75	13.00
	2	5.00	2.25	8.50	5.38	5.75	13.00
	3	3.50	2.25	8.50	5.38	5.75	13.00
	4	4.00	2.25	8.50	5.38	5.75	13.00
	5	4.50	2.25	8.50	5.38	5.75	13.00
8.00	1 (std.)	3.50	2.25	9.50	6.13	6.75	14.00
	2	5.50	2.25	9.50	6.13	6.75	14.00
	3	4.00	2.25	9.50	6.13	6.75	14.00
	4	4.50	2.25	9.50	6.13	6.75	14.00
	5	5.00	2.25	9.50	6.13	6.75	14.00
Replaces On single rod mounting styles:				LB	SN	SS	-
				All Mtg. Styles	F	C	All Mtg. Styles

How to Use Double Rod Cylinder
Dimension Drawings

To determine dimensions for a double rod cylinder, first refer to the desired single rod mounting style cylinder shown on preceding pages of this catalog. (See table above.) After selecting necessary dimensions from that drawing, return to this page supplement the single rod dimensions with those shown on drawing at right and dimension table below. Note that double rod cylinders have a head (Dim. G) at both ends and that dimension LD replaces LB. The double rod dimensions differ from, or are in addition to those for single

rod cylinders shown on preceding pages and provide the information needed to completely dimension a double rod cylinder.

On a double rod cylinder where the two rod ends are different, be sure to clearly state which rod end is to be assembled at which end. Port position 1 is standard. If other than standard, specify pos. 2, 3 or 4 when viewed from rod end #1 only. See port position information in Section E.

**Tie Rods Extended Both Ends Mounting
Style TD
(NFFPA Style MX1)**

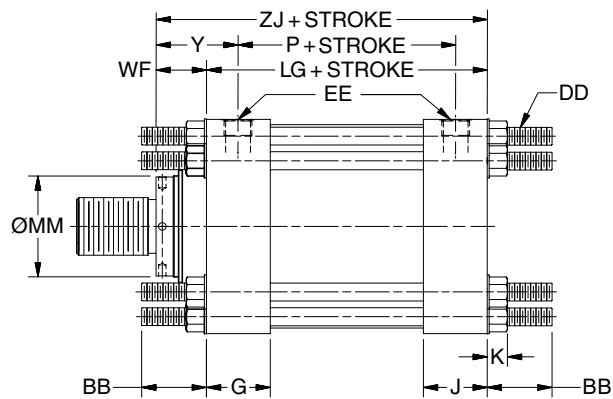
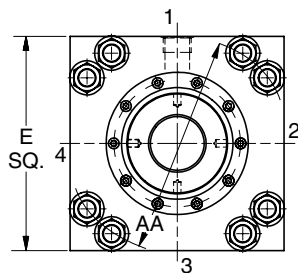
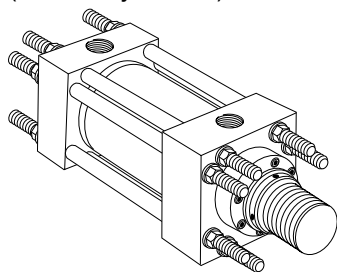

Style TD – Dimensional and Mounting Data

Bore Ø	Rod No.	MM Rod Ø	AA	BB	DD	E	EE			G	J	K	WF	Y	Add Stroke		
							NPTF ¹	SAE Flange Ports ²	SAE Straight Thread ³						LG	P	ZJ
10.00	1 (std.)	4.500	13.00	4.13	1 1/8-12	12.63	2.00	2.00	24	3.69	3.69	1.28	2.94	4.75	12.13	8.50	15.06
	2	7.000	13.00	4.13	1 1/8-12	12.63	2.00	2.00	24	3.69	3.69	1.28	3.50	5.31	12.13	8.50	15.63
	3	5.000	13.00	4.13	1 1/8-12	12.63	2.00	2.00	24	3.69	3.69	1.28	3.19	5.00	12.13	8.50	15.31
	4	5.500	13.00	4.13	1 1/8-12	12.63	2.00	2.00	24	3.69	3.69	1.28	3.19	5.00	12.13	8.50	15.31
12.00	1 (std.)	5.500	15.50	4.50	1 1/4-12	14.88	2.50	2.50	24	4.44	4.44	1.41	3.19	5.38	14.50	10.13	17.69
	2	8.000	15.50	4.50	1 1/4-12	14.88	2.50	2.50	24	4.44	4.44	1.41	4.00	6.19	14.50	10.13	18.50
	3	7.000	15.50	4.50	1 1/4-12	14.88	2.50	2.50	24	4.44	4.44	1.41	3.50	5.69	14.50	10.13	18.00
14.00	1 (std.)	7.000	17.38	4.50	1 1/4-12	17.13	2.50	2.50	24	4.88	4.88	1.41	3.50	5.88	15.63	10.88	19.13
	2	10.000	17.38	4.50	1 1/4-12	17.13	2.50	2.50	24	4.88	4.88	1.41	4.50	6.88	15.63	10.88	20.13
	3	8.000	17.38	4.50	1 1/4-12	17.13	2.50	2.50	24	4.88	4.88	1.41	4.00	6.38	15.63	10.88	19.63

¹ NPTF ports are available at no extra charge.

² Optional SAE flange ports may be specified – flange to be supplied by customer. See Optional SAE Flange Port Pattern table for dimensions.

³ SAE straight thread ports are standard and are indicated by port number.

Optional SAE Flange Port Pattern

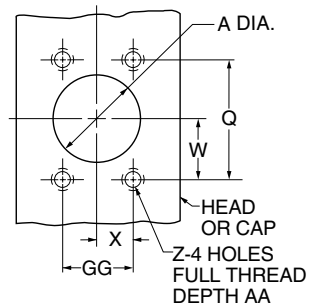

Nom. Flange Size	A	Q	GG	W	X	Z-THD UNC-2B	AA Min.	SAE
2	2.00	3.062	1.688	1.53	0.84	1/2-13	1.06	32
2 1/2	2.50	3.500	2.000	1.75	1.00	1/2-13	1.19	40

Style TD – Tie Rod Information

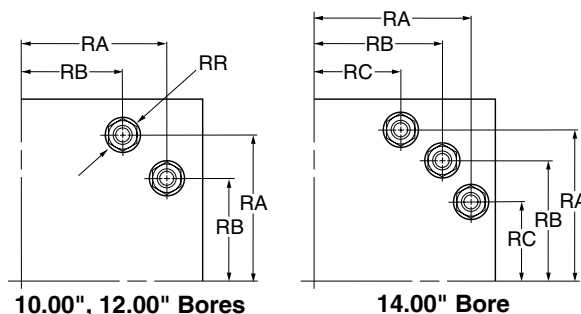

Bore Ø	10.00	12.00	14.00
Tie Rod Thread	1 1/8-12	1 1/4-12	1 1/4-12
RA	5.291	6.270	7.485
RB	3.775	4.555	6.143
RC	—	—	4.409
RR	2.13	2.38	2.25

Style TB

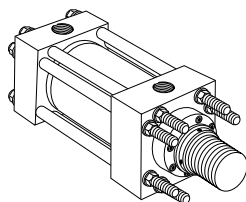

Style TC

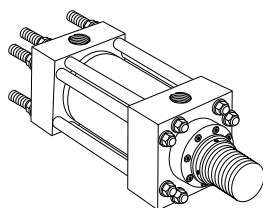

Dimensions for TB and TC Mount may be obtained from the above dimensional table.



Mounting Information – Large Bore

Head Rectangular Mounting
Style JJ (10"-14" Bore)
(NFPA Style ME5)

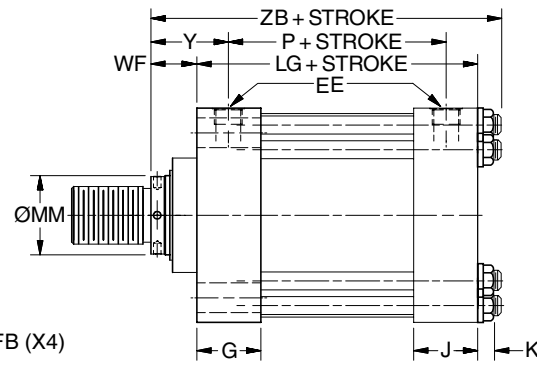
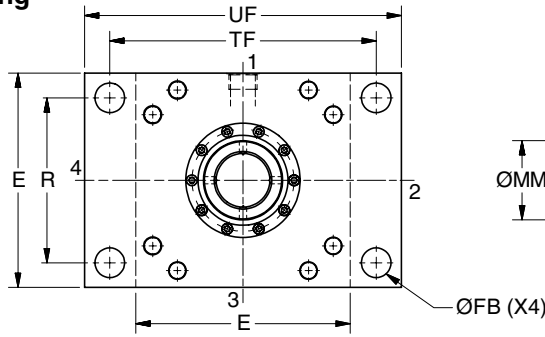
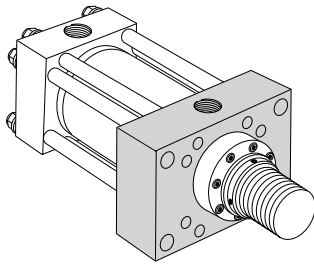

Style JJ (10"-14" Bore) – Dimensional and Mounting Data

Bore Ø	Rod No.	MM Rod Ø	E	Ports (EE)			FB Ø	G	J	K	R	TF	UF	WF	Y	Add Stroke		
				NPTF ¹	SAE Flange Port ²	SAE Straight Thread Port ³										LG	P	ZB Max.
10.00	1 (std.)	4.500	12.63	2.00	2.00	24	1.81	3.69	3.69	1.28	9.62	15.88	19.00	2.94	4.75	12.13	8.50	16.69
	2	7.000	12.63	2.00	2.00	24	1.81	3.69	3.69	1.28	9.62	15.88	19.00	3.50	5.31	12.13	8.50	17.25
	3	5.000	12.63	2.00	2.00	24	1.81	3.69	3.69	1.28	9.62	15.88	19.00	3.19	5.00	12.13	8.50	16.94
	4	5.500	12.63	2.00	2.00	24	1.81	3.69	3.69	1.28	9.62	15.88	19.00	3.19	5.00	12.13	8.50	16.94
12.00	1 (std.)	5.500	14.88	2.50	2.50	24	2.06	4.44	4.44	1.41	11.45	18.50	22.00	3.19	5.38	14.50	10.13	19.44
	2	8.000	14.88	2.50	2.50	24	2.06	4.44	4.44	1.41	11.45	18.50	22.00	4.00	6.19	14.50	10.13	20.25
	3	7.000	14.88	2.50	2.50	24	2.06	4.44	4.44	1.41	11.45	18.50	22.00	3.50	5.69	14.50	10.13	19.75
14.00	1 (std.)	7.000	17.13	2.50	2.50	24	2.31	4.88	4.88	1.41	13.26	21.00	25.00	3.50	5.88	15.63	10.88	20.88
	2	10.000	17.13	2.50	2.50	24	2.31	4.88	4.88	1.41	13.26	21.00	25.00	4.50	6.88	15.63	10.88	21.88
	3	8.000	17.13	2.50	2.50	24	2.31	4.88	4.88	1.41	13.26	21.00	25.00	4.00	6.38	15.63	10.88	21.38

¹ NPTF ports are available at no extra charge.

² Optional SAE flange ports may be specified – flange to be supplied by customer. See Optional SAE Flange Port Pattern table for dimensions.

³ SAE straight thread ports are standard and are indicated by port number.

Optional SAE Flange Port Pattern

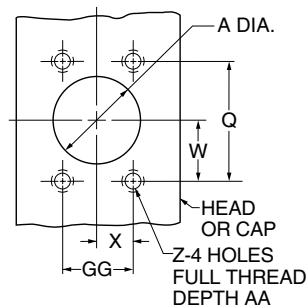

Nom. Flange Size	A	Q	GG	W	X	Z-THD UNC-2B	AA Min.	SAE
2	2.00	3.062	1.688	1.53	0.84	1/2-13	1.06	32
2 1/2	2.50	3.500	2.000	1.75	1.00	1/2-13	1.19	40

Mounting Information – Large Bore

Head Rectangular Mounting
Style JJ (16"-20" Bore)
(NFPA Style ME5)

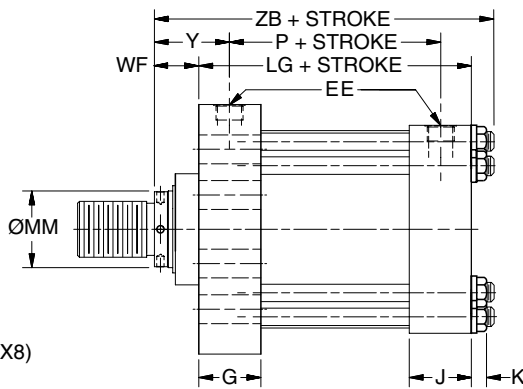
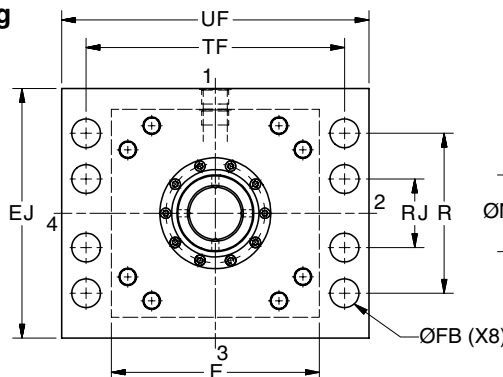
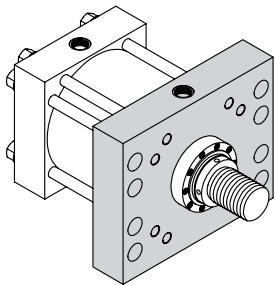

Style JJ (16"-20" Bore) – Dimensional and Mounting Data

Bore Ø	Rod No.	MM Rod Ø	E	EJ	Ports (EE)		FB Ø	G	J	K	R	RJ	TF	UF	WF	Y	Add Stroke		
					SAE Flange Port ¹	SAE Straight Thread Port ²											LG	P	ZB Max.
16.00	1 (std.)	8.000	19.00	20.00	3.00	24	1.81	5.88	5.88	1.91	15.50	8.00	21.00	24.50	4.00	7.00	18.13	12.13	24.38
	3	9.000	19.00	20.00	3.00	24	1.81	5.88	5.88	1.91	15.50	8.00	21.00	24.50	4.25	7.25	18.13	12.13	24.63
	4	10.000	19.00	20.00	3.00	24	1.81	5.88	5.88	1.91	15.50	8.00	21.00	24.50	4.50	7.50	18.13	12.13	24.88
18.00	1 (std.)	9.000	22.00	23.00	3.00	24	2.06	6.88	6.88	1.91	18.00	7.25	24.25	28.25	4.25	7.25	21.13	15.13	27.63
	3	10.000	22.00	23.00	3.00	24	2.06	6.88	6.88	1.91	18.00	7.25	24.25	28.25	4.50	7.50	21.13	15.13	27.88
20.00	1 (std.)	10.000	24.00	25.00	3.00	24	2.06	7.88	7.88	1.91	20.00	8.00	26.50	30.50	4.50	7.50	23.63	17.63	30.38

¹Optional SAE flange ports may be specified – flange to be supplied by customer. See Optional SAE Flange Port Pattern table for dimensions.

²SAE straight thread ports are standard and are indicated by port number.

Optional SAE Flange Port Pattern

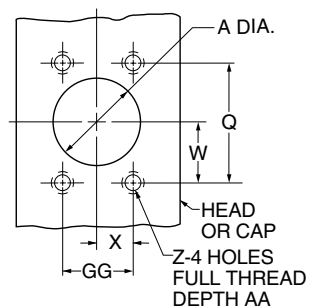

Nom. Flange Size	A	Q	GG	W	X	Z-THD UNC-2B	AA Min.	SAE
3	3.00	4.188	2.438	2.09	1.22	5/8-11	1.19	48



Head Square Flange Mounting
Style JB
(NFA Style MF5)

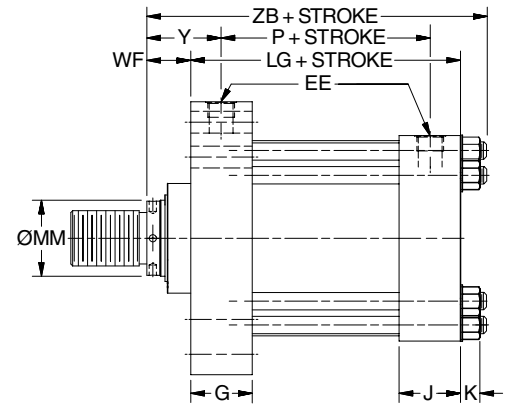
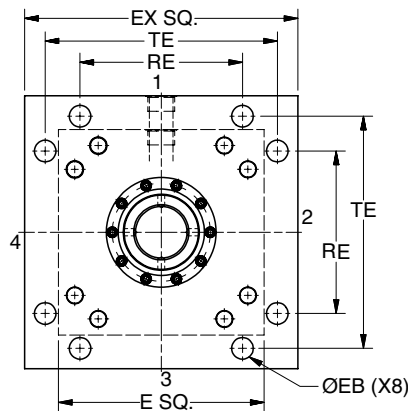
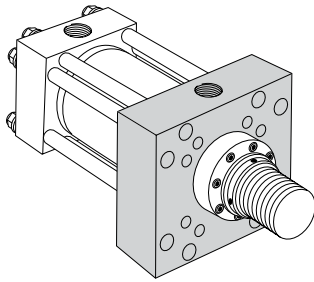

Style JB – Dimensional and Mounting Data

Bore Ø	Rod No.	MM Rod Ø	E	EB Ø	Ports (EE)			EX	G	J	K	RE	TE	WF	Y	Add Stroke		
					NPTF ¹	SAE Flange Port ²	SAE Straight Thread Port ³									LG	P	ZB Max.
10.00	1 (std.)	4.500	12.63	1.31	2.00	2.00	24	16.63	3.69	3.69	1.28	9.89	14.13	2.94	4.75	12.13	8.50	16.69
	2	7.000	12.63	1.31	2.00	2.00	24	16.63	3.69	3.69	1.28	9.89	14.13	3.50	5.31	12.13	8.50	17.25
	3	5.000	12.63	1.31	2.00	2.00	24	16.63	3.69	3.69	1.28	9.89	14.13	3.19	5.00	12.13	8.50	16.94
	4	5.500	12.63	1.31	2.00	2.00	24	16.63	3.69	3.69	1.28	9.89	14.13	3.19	5.00	12.13	8.50	16.94
12.00	1 (std.)	5.500	14.88	1.56	2.50	2.50	24	19.75	4.44	4.44	1.41	11.75	16.79	3.19	5.38	14.50	10.13	19.44
	2	8.000	14.88	1.56	2.50	2.50	24	19.75	4.44	4.44	1.41	11.75	16.79	4.00	6.19	14.50	10.13	20.25
	3	7.000	14.88	1.56	2.50	2.50	24	19.75	4.44	4.44	1.41	11.75	16.79	3.50	5.69	14.50	10.13	19.75
14.00	1 (std.)	7.000	17.13	1.81	2.50	2.50	24	21.75	4.88	4.88	1.41	12.90	18.43	3.50	5.88	15.63	10.88	20.88
	2	10.000	17.13	1.81	2.50	2.50	24	21.75	4.88	4.88	1.41	12.90	18.43	4.50	6.88	15.63	10.88	21.88
	3	8.000	17.13	1.81	2.50	2.50	24	21.75	4.88	4.88	1.41	12.90	18.43	4.00	6.38	15.63	10.88	21.38
16.00	1 (std.)	8.000	19.00	1.81	-	3.00	24	24.50	5.88	5.88	1.91	15.28	21.03	4.00	7.00	18.13	12.13	24.38
	3	9.000	19.00	1.81	-	3.00	24	24.50	5.88	5.88	1.91	15.28	21.03	4.25	7.25	18.13	12.13	24.63
	4	10.000	19.00	1.81	-	3.00	24	24.50	5.88	5.88	1.91	15.28	21.03	4.50	7.50	18.13	12.13	24.88
18.00	1 (std.)	9.000	22.00	2.06	-	3.00	24	26.50	6.88	6.88	1.91	16.45	22.65	4.25	7.25	21.13	15.13	27.63
	3	10.000	22.00	2.06	-	3.00	24	26.50	6.88	6.88	1.91	16.45	22.65	4.50	7.50	21.13	15.13	27.88
20.00	1 (std.)	10.000	24.00	2.06	-	3.00	24	29.00	7.88	7.88	1.91	18.07	24.87	4.50	7.50	23.63	17.63	30.38

¹NPTF ports are available at no extra charge.

²Optional SAE flange ports may be specified – flange to be supplied by customer. See Optional SAE Flange Port Pattern table for dimensions.

³SAE straight thread ports are standard and are indicated by port number.

Optional SAE Flange Port Pattern

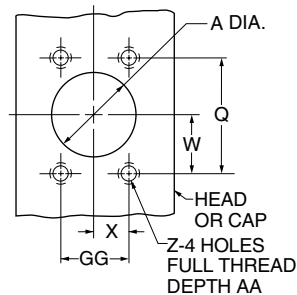

Nom. Flange Size	A	Q	GG	W	X	Z-THD UNC-2B	AA Min.	SAE
2	2.00	3.062	1.688	1.53	0.84	1/2-13	1.06	32
2 1/2	2.50	3.500	2.000	1.75	1.00	1/2-13	1.19	40
3	3.00	4.188	2.438	2.09	1.22	5/8-11	1.19	48

Mounting Information – Large Bore

Cap Rectangular Mounting
Style HH
(NFPA Style ME6)

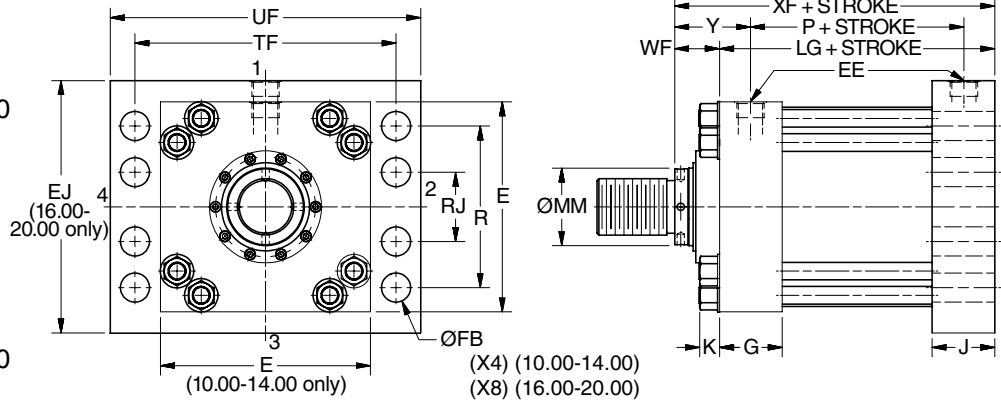
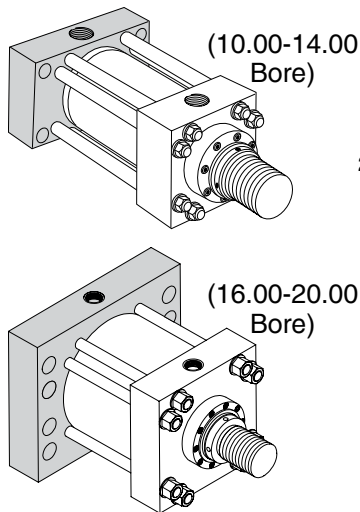

Style HH – Dimensional and Mounting Data

Bore Ø	Rod No.	MM Rod Ø	E	Ports (EE)			EJ	FB Ø	G	J	K	R	RJ	TF	UF	WF	Y	Add Stroke		
				NPTF ¹	SAE Flange Port ²	SAE Straight Thread Port ³												LG	P	XF
10.00	1 (std.)	4.500	12.63	2.00	2.00	24	-	1.81	3.69	3.69	1.28	9.62	-	15.88	19.00	2.94	4.75	12.13	8.50	15.06
	2	7.000	12.63	2.00	2.00	24	-	1.81	3.69	3.69	1.28	9.62	-	15.88	19.00	3.50	5.31	12.13	8.50	15.63
	3	5.000	12.63	2.00	2.00	24	-	1.81	3.69	3.69	1.28	9.62	-	15.88	19.00	3.19	5.00	12.13	8.50	15.31
	4	5.500	12.63	2.00	2.00	24	-	1.81	3.69	3.69	1.28	9.62	-	15.88	19.00	3.19	5.00	12.13	8.50	15.31
12.00	1 (std.)	5.500	14.88	2.50	2.50	24	-	2.06	4.44	4.44	1.41	11.45	-	18.50	22.00	3.19	5.38	14.50	10.13	17.69
	2	8.000	14.88	2.50	2.50	24	-	2.06	4.44	4.44	1.41	11.45	-	18.50	22.00	4.00	6.19	14.50	10.13	18.50
	3	7.000	14.88	2.50	2.50	24	-	2.06	4.44	4.44	1.41	11.45	-	18.50	22.00	3.50	5.69	14.50	10.13	18.00
14.00	1 (std.)	7.000	17.13	2.50	2.50	24	-	2.31	4.88	4.88	1.41	13.26	-	21.00	25.00	3.50	5.88	15.63	10.88	19.13
	2	10.000	17.13	2.50	2.50	24	-	2.31	4.88	4.88	1.41	13.26	-	21.00	25.00	4.50	6.88	15.63	10.88	20.13
	3	8.000	17.13	2.50	2.50	24	-	2.31	4.88	4.88	1.41	13.26	-	21.00	25.00	4.00	6.38	15.63	10.88	19.63
16.00	1 (std.)	8.000	-	-	3.00	24	20.00	1.81	5.88	5.88	1.91	15.50	8.00	21.00	24.50	4.00	7.00	18.13	12.13	22.13
	3	9.000	-	-	3.00	24	20.00	1.81	5.88	5.88	1.91	15.50	8.00	21.00	24.50	4.25	7.25	18.13	12.13	22.38
	4	10.000	-	-	3.00	24	20.00	1.81	5.88	5.88	1.91	15.50	8.00	21.00	24.50	4.50	7.50	18.13	12.13	22.63
18.00	1 (std.)	9.000	-	-	3.00	24	23.00	2.06	6.88	6.88	1.91	18.00	7.25	24.25	28.25	4.25	7.25	21.13	15.13	25.38
	3	10.000	-	-	3.00	24	23.00	2.06	6.88	6.88	1.91	18.00	7.25	24.25	28.25	4.50	7.50	21.13	15.13	25.63
20.00	1 (std.)	10.000	-	-	3.00	24	25.00	2.06	7.88	7.88	1.91	20.00	8.00	26.50	30.50	4.50	7.50	23.63	17.63	28.13

¹NPTF ports are available at no extra charge.

²Optional SAE flange ports may be specified – flange to be supplied by customer. See Optional SAE Flange Port Pattern table for dimensions.

³SAE straight thread ports are standard and are indicated by port number.

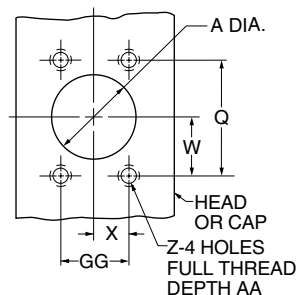

Optional SAE Flange Port Pattern

Nom. Flange Size	A	Q	GG	W	X	Z-THD UNC-2B	AA Min.	SAE
2	2.00	3.062	1.688	1.53	0.84	1/2-13	1.06	32
2 1/2	2.50	3.500	2.000	1.75	1.00	1/2-13	1.19	40
3	3.00	4.188	2.438	2.09	1.22	5/8-11	1.19	48



Mounting Information – Large Bore

Cap Square Flange Mounting
Style HB
(NFPA Style MF6)

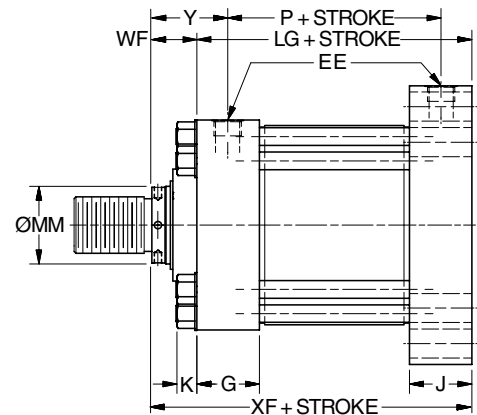
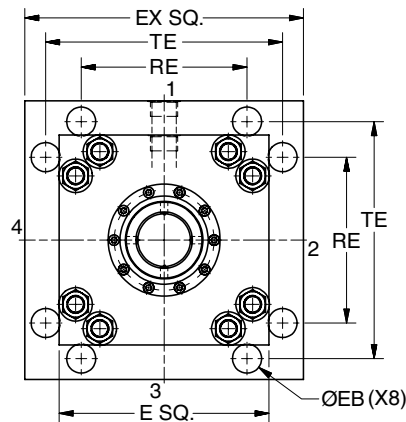
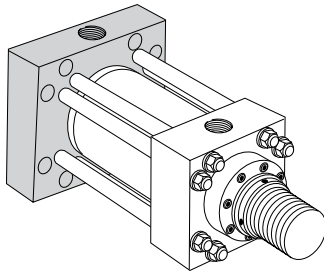

Style HB – Dimensional and Mounting Data

Bore Ø	Rod No.	MM Rod Ø	E	EB Ø	Ports (EE)			EX	G	J	K	RE	TE	WF	Y	Add Stroke		
					NPTF ¹	SAE Flange Port ²	SAE Straight Thread Port ³									LG	P	XF
10.00	1 (std.)	4.500	12.63	1.31	2.00	2.00	24	16.63	3.69	3.69	1.28	9.89	14.13	2.94	4.75	12.13	8.50	15.06
	2	7.000	12.63	1.31	2.00	2.00	24	16.63	3.69	3.69	1.28	9.89	14.13	3.50	5.31	12.13	8.50	15.63
	3	5.000	12.63	1.31	2.00	2.00	24	16.63	3.69	3.69	1.28	9.89	14.13	3.19	5.00	12.13	8.50	15.31
	4	5.500	12.63	1.31	2.00	2.00	24	16.63	3.69	3.69	1.28	9.89	14.13	3.19	5.00	12.13	8.50	15.31
12.00	1 (std.)	5.500	14.88	1.56	2.50	2.50	24	19.75	4.44	4.44	1.41	11.75	16.79	3.19	5.38	14.50	10.13	17.69
	2	8.000	14.88	1.56	2.50	2.50	24	19.75	4.44	4.44	1.41	11.75	16.79	4.00	6.19	14.50	10.13	18.50
	3	7.000	14.88	1.56	2.50	2.50	24	19.75	4.44	4.44	1.41	11.75	16.79	3.50	5.69	14.50	10.13	18.00
14.00	1 (std.)	7.000	17.13	1.81	2.50	2.50	24	21.75	4.88	4.88	1.41	12.90	18.43	3.50	5.88	15.63	10.88	19.13
	2	10.000	17.13	1.81	2.50	2.50	24	21.75	4.88	4.88	1.41	12.90	18.43	4.50	6.88	15.63	10.88	20.13
	3	8.000	17.13	1.81	2.50	2.50	24	21.75	4.88	4.88	1.41	12.90	18.43	4.00	6.38	15.63	10.88	19.63
16.00	1 (std.)	8.000	19.00	1.81	-	3.00	24	24.50	5.88	5.88	1.91	15.28	21.03	4.00	7.00	18.13	12.13	22.13
	3	9.000	19.00	1.81	-	3.00	24	24.50	5.88	5.88	1.91	15.28	21.03	4.25	7.25	18.13	12.13	22.38
	4	10.000	19.00	1.81	-	3.00	24	24.50	5.88	5.88	1.91	15.28	21.03	4.50	7.50	18.13	12.13	22.63
18.00	1 (std.)	9.000	22.00	2.06	-	3.00	24	26.50	6.88	6.88	1.91	16.45	22.65	4.25	7.25	21.13	15.13	25.38
	3	10.000	22.00	2.06	-	3.00	24	26.50	6.88	6.88	1.91	16.45	22.65	4.50	7.50	21.13	15.13	25.63
20.00	1 (std.)	10.000	24.00	2.06	-	3.00	24	29.00	7.88	7.88	1.91	18.07	24.87	4.50	7.50	23.63	17.63	28.13

¹NPTF ports are available at no extra charge.

²Optional SAE flange ports may be specified – flange to be supplied by customer. See Optional SAE Flange Port Pattern table for dimensions.

³SAE straight thread ports are standard and are indicated by port number.

Optional SAE Flange Port Pattern

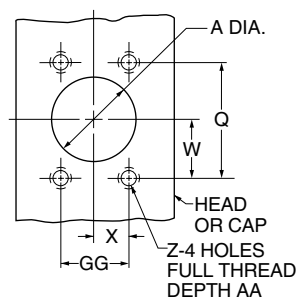

Nom. Flange Size	A	Q	GG	W	X	Z-THD UNC-2B	AA Min.	SAE
2	2.00	3.062	1.688	1.53	0.84	1/2-13	1.06	32
2 1/2	2.50	3.500	2.000	1.75	1.00	1/2-13	1.19	40
3	3.00	4.188	2.438	2.09	1.22	5/8-11	1.19	48

Side Lugs Mounting
Style C
(NFPA Style MS2)

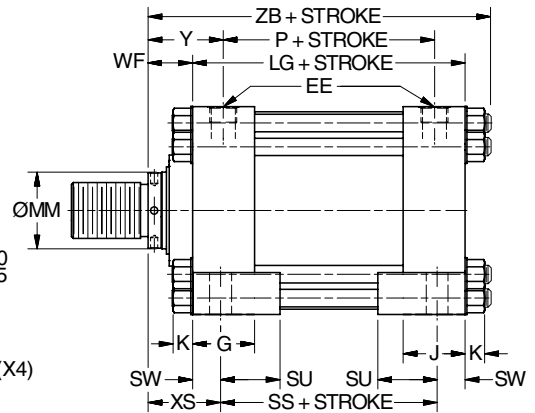
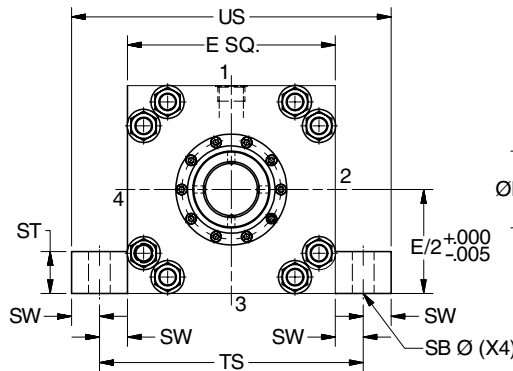
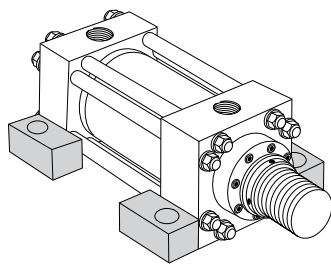

Style C – Dimensional and Mounting Data

Bore Ø	Rod No.	MM Rod Ø	E	Ports (EE)			G	J	K	SB Ø	ST	SU	SW	Y	TS	US	WF	XS
				NPTF ¹	SAE Flange Port ²	SAE Straight Thread Port ³												
10.00	1 (std.)	4.500	12.63	2.00	2.00	24	3.69	3.69	1.28	1.563	2.25	3.50	1.63	4.75	15.88	19.13	2.94	4.56
	2	7.000	12.63	2.00	2.00	24	3.69	3.69	1.28	1.563	2.25	3.50	1.63	5.31	15.88	19.13	3.50	5.13
	3	5.000	12.63	2.00	2.00	24	3.69	3.69	1.28	1.563	2.25	3.50	1.63	5.00	15.88	19.13	3.19	4.81
	4	5.500	12.63	2.00	2.00	24	3.69	3.69	1.28	1.563	2.25	3.50	1.63	5.00	15.88	19.13	3.19	4.81
12.00	1 (std.)	5.500	14.88	2.50	2.50	24	4.44	4.44	1.41	1.563	3.00	4.25	2.00	5.38	18.88	22.88	3.19	5.19
	2	8.000	14.88	2.50	2.50	24	4.44	4.44	1.41	1.563	3.00	4.25	2.00	6.19	18.88	22.88	4.00	6.00
	3	7.000	14.88	2.50	2.50	24	4.44	4.44	1.41	1.563	3.00	4.25	2.00	5.69	18.88	22.88	3.50	5.50
14.00	1 (std.)	7.000	17.13	2.50	2.50	24	4.88	4.88	1.41	2.313	4.00	4.75	2.25	5.88	21.63	26.13	3.50	5.75
	2	10.000	17.13	2.50	2.50	24	4.88	4.88	1.41	2.313	4.00	4.75	2.25	6.88	21.63	26.13	4.50	6.75
	3	8.000	17.13	2.50	2.50	24	4.88	4.88	1.41	2.313	4.00	4.75	2.25	6.38	21.63	26.13	4.00	6.25

¹NPTF ports are available at no extra charge.

²Optional SAE flange ports may be specified – flange to be supplied by customer. See Optional SAE Flange Port Pattern table for dimensions.

³SAE straight thread ports are standard and are indicated by port number.

Style C – Dimensional and Mounting Data (cont.)

Bore Ø	Rod No.	MM Rod Ø	Add Stroke			
			LG	P	SS	ZB Max.
10.00	1 (std.)	4.500	12.13	8.50	8.88	16.69
	2	7.000	12.13	8.50	8.88	17.25
	3	5.000	12.13	8.50	8.88	16.94
	4	5.500	12.13	8.50	8.88	16.94
12.00	1 (std.)	5.500	14.50	10.13	10.50	19.44
	2	8.000	14.50	10.13	10.50	20.25
	3	7.000	14.50	10.13	10.50	19.75
14.00	1 (std.)	7.000	15.63	10.88	11.13	20.88
	2	10.000	15.63	10.88	11.13	21.88
	3	8.000	15.63	10.88	11.13	21.38

Optional SAE Flange Port Pattern

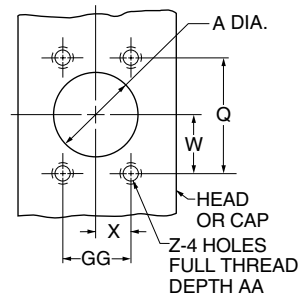

Nom. Flange Size	A	Q	GG	W	X	Z-THD UNC-2B	AA Min.	SAE
2	2.00	3.062	1.688	1.53	0.84	1/2-13	1.06	32
2 1/2	2.50	3.500	2.000	1.75	1.00	1/2-13	1.19	40



Mounting Information – Large Bore

Cap Fixed Clevis Mounting
Style BB
(NFPA Style MP1)

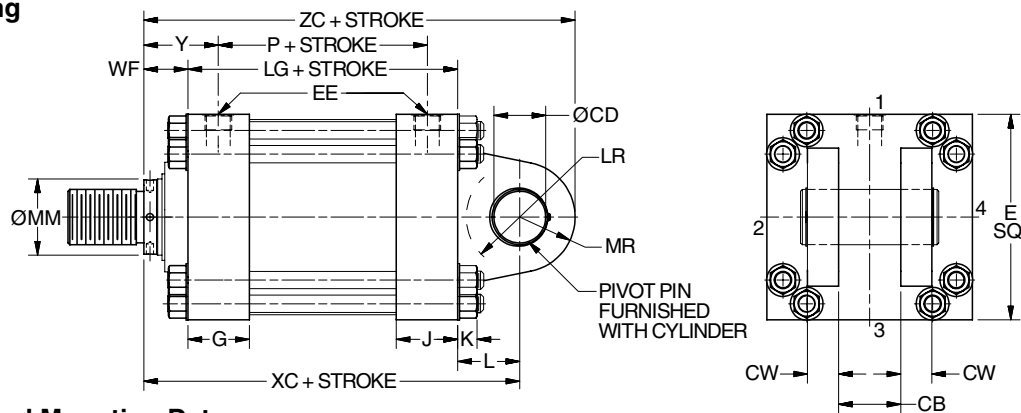
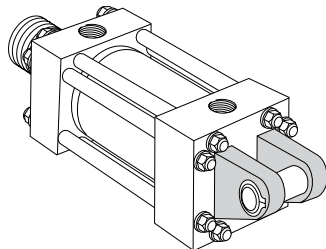

Style BB – Dimensional and Mounting Data

Bore Ø	Rod No.	MM Rod Ø	CB	CD Ø +.001 -.003	CW	E	EE Ports			G	J	K	L	LR	MR	WF	Y	Add Stroke			
							NPTF ¹	SAE Flange Port ²	SAE Straight Thread Port ³									LG	P	XC	ZC
10.00	1 (std.)	4.500	4.00	3.500	2.00	12.63	2.00	2.00	24	3.69	3.69	1.28	4.00	3.38	3.50	2.94	4.75	12.13	8.50	19.06	22.56
	2	7.000	4.00	3.500	2.00	12.63	2.00	2.00	24	3.69	3.69	1.28	4.00	3.38	3.50	3.50	5.31	12.13	8.50	19.63	23.13
	3	5.000	4.00	3.500	2.00	12.63	2.00	2.00	24	3.69	3.69	1.28	4.00	3.38	3.50	3.19	5.00	12.13	8.50	19.31	22.81
	4	5.500	4.00	3.500	2.00	12.63	2.00	2.00	24	3.69	3.69	1.28	4.00	3.38	3.50	3.19	5.00	12.13	8.50	19.31	22.81
12.00	1 (std.)	5.500	4.50	4.000	2.25	14.88	2.50	2.50	24	4.44	4.44	1.41	4.50	3.88	4.00	3.19	5.38	14.50	10.13	22.19	26.19
	2	8.000	4.50	4.000	2.25	14.88	2.50	2.50	24	4.44	4.44	1.41	4.50	3.88	4.00	4.00	6.19	14.50	10.13	23.00	27.00
	3	7.000	4.50	4.000	2.25	14.88	2.50	2.50	24	4.44	4.44	1.41	4.50	3.88	4.00	3.50	5.69	14.50	10.13	22.50	26.50
14.00	1 (std.)	7.000	6.00	5.000	3.00	17.13	2.50	2.50	24	4.88	4.88	1.41	5.75	4.19	5.00	3.50	5.88	15.63	10.88	24.88	29.88
	2	10.000	6.00	5.000	3.00	17.13	2.50	2.50	24	4.88	4.88	1.41	5.75	4.19	5.00	4.50	6.88	15.63	10.88	25.88	30.88
	3	8.000	6.00	5.000	3.00	17.13	2.50	2.50	24	4.88	4.88	1.41	5.75	4.19	5.00	4.00	6.38	15.63	10.88	25.38	30.38
16.00	1 (std.)	8.000	7.00	6.000	3.50	19.00	-	3.00	24	5.88	5.88	1.91	7.00	6.25	6.00	4.00	7.00	18.13	12.13	29.13	35.13
	3	9.000	7.00	6.000	3.50	19.00	-	3.00	24	5.88	5.88	1.91	7.00	6.25	6.00	4.25	7.25	18.13	12.13	29.38	35.38
	4	10.000	7.00	6.000	3.50	19.00	-	3.00	24	5.88	5.88	1.91	7.00	6.25	6.00	4.50	7.50	18.13	12.13	29.63	35.63
18.00	1 (std.)	9.000	8.00	6.500	4.00	22.00	-	3.00	24	6.88	6.88	1.91	7.63	6.75	6.50	4.25	7.25	21.13	15.13	33.00	39.50
	3	10.000	8.00	6.500	4.00	22.00	-	3.00	24	6.88	6.88	1.91	7.63	6.75	6.50	4.50	7.50	21.13	15.13	33.25	39.75
20.00	1 (std.)	10.000	9.00	7.500	4.50	24.00	-	3.00	24	7.88	7.88	1.91	8.75	7.75	7.50	4.50	7.50	23.63	17.63	36.88	44.38

¹NPTF ports are available at no extra charge.

²Optional SAE flange ports may be specified – flange to be supplied by customer. See Optional SAE Flange Port Pattern table for dimensions.

³SAE straight thread ports are standard and are indicated by port number.

Optional SAE Flange Port Pattern

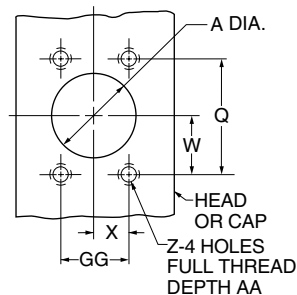

Nom. Flange Size	A	Q	GG	W	X	Z-THD UNC-2B	AA Min.	SAE
2	2.00	3.062	1.688	1.53	0.84	1/2-13	1.06	32
2 1/2	2.50	3.500	2.000	1.75	1.00	1/2-13	1.19	40
3	3.00	4.188	2.438	2.09	1.22	5/8-11	1.19	48

Head Trunnion Mounting
Style D
(NFA Style MT1)

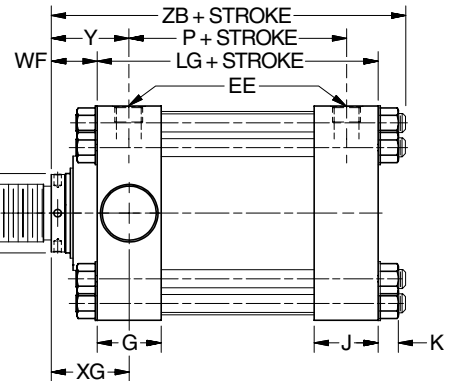
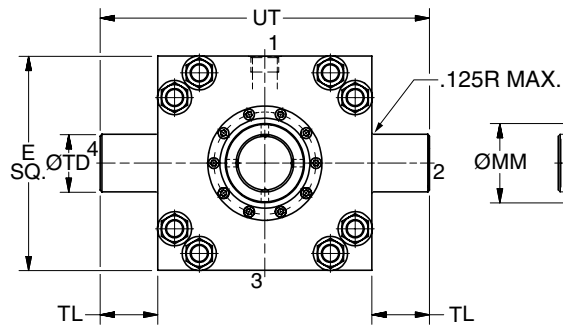
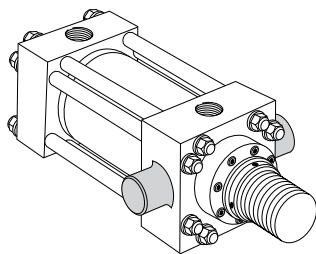

Style D – Dimensional and Mounting Data

Bore Ø	Rod No.	MM Rod Ø	E	Ports (EE)			G	J	K	TD Ø +.000 -.001	TL	UT	WF	XG	Y	Add Stroke		
				NPTF ¹	SAE Flange Port ²	SAE Straight Thread Port ³										LG	P	ZB Max.
10.00	1 (std.)	4.500	12.63	2.00	2.00	24	3.69	3.69	1.28	3.500	3.50	19.63	2.94	4.75	4.75	12.13	8.50	16.69
	2	7.000	12.63	2.00	2.00	24	3.69	3.69	1.28	3.500	3.50	19.63	3.50	5.31	5.31	12.13	8.50	17.25
	3	5.000	12.63	2.00	2.00	24	3.69	3.69	1.28	3.500	3.50	19.63	3.19	5.00	5.00	12.13	8.50	16.94
	4	5.500	12.63	2.00	2.00	24	3.69	3.69	1.28	3.500	3.50	19.63	3.19	5.00	5.00	12.13	8.50	16.94
12.00	1 (std.)	5.500	14.88	2.50	2.50	24	4.44	4.44	1.41	4.000	4.00	22.88	3.19	5.38	5.38	14.50	10.13	19.44
	2	8.000	14.88	2.50	2.50	24	4.44	4.44	1.41	4.000	4.00	22.88	4.00	6.19	6.19	14.50	10.13	20.25
	3	7.000	14.88	2.50	2.50	24	4.44	4.44	1.41	4.000	4.00	22.88	3.50	5.69	5.69	14.50	10.13	19.75
14.00	1 (std.)	7.000	17.13	2.50	2.50	24	4.88	4.88	1.41	4.500	4.50	26.13	3.50	5.94	5.88	15.63	10.88	20.88
	2	10.000	17.13	2.50	2.50	24	4.88	4.88	1.41	4.500	4.50	26.13	4.50	6.94	6.88	15.63	10.88	21.88
	3	8.000	17.13	2.50	2.50	24	4.88	4.88	1.41	4.500	4.50	26.13	4.00	6.44	6.38	15.63	10.88	21.38

¹NPTF ports are available at no extra charge.

²Optional SAE flange ports may be specified – flange to be supplied by customer. See Optional SAE Flange Port Pattern table for dimensions.

³SAE straight thread ports are standard and are indicated by port number.

Optional SAE Flange Port Pattern

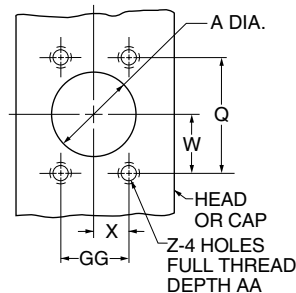

Nom. Flange Size	A	Q	GG	W	X	Z-THD UNC-2B	AA Min.	SAE
2	2.00	3.062	1.688	1.53	0.84	1/2-13	1.06	32
2 1/2	2.50	3.500	2.000	1.75	1.00	1/2-13	1.19	40

Style D – Maximum Operating Pressure

Bore Ø	psi
10.00	2800
12.00	2350
14.00	2200



Cap Trunnion Mounting
Style DB
(NFPA Style MT2)

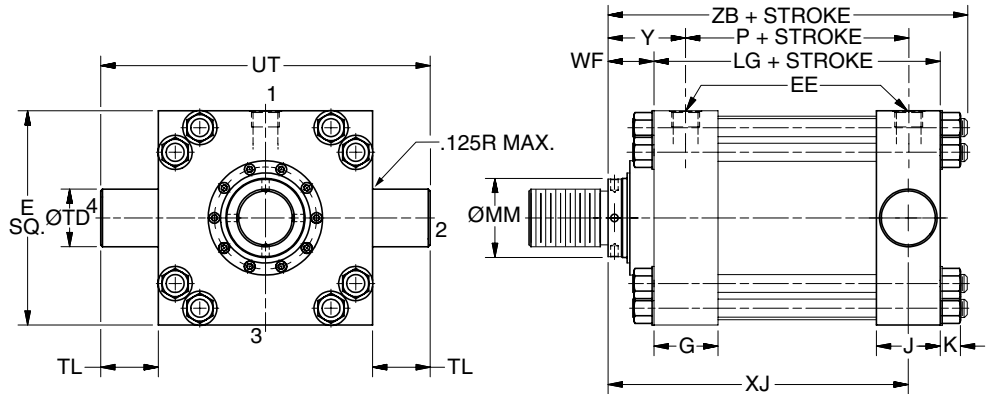
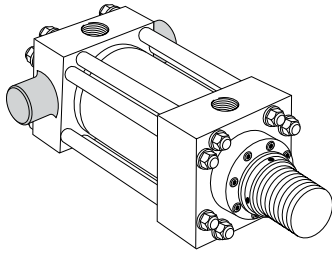

Style DB – Dimensional and Mounting Data

Bore Ø	Rod No.	MM Rod Ø	E	Ports (EE)			G	J	K	TD Ø +.000 -.001	TL	UT	WF	Y	Add Stroke			
				NPTF ¹	SAE Flange Port ²	SAE Straight Thread Port ³									LG	P	XJ	ZB Max.
10.00	1 (std.)	4.500	12.63	2.00	2.00	24	3.69	3.69	1.28	3.500	3.50	19.63	2.94	4.75	12.13	8.50	13.38	16.69
	2	7.000	12.63	2.00	2.00	24	3.69	3.69	1.28	3.500	3.50	19.63	3.50	5.31	12.13	8.50	13.94	17.25
	3	5.000	12.63	2.00	2.00	24	3.69	3.69	1.28	3.500	3.50	19.63	3.19	5.00	12.13	8.50	13.63	16.94
	4	5.500	12.63	2.00	2.00	24	3.69	3.69	1.28	3.500	3.50	19.63	3.19	5.00	12.13	8.50	13.63	16.94
12.00	1 (std.)	5.500	14.88	2.50	2.50	24	4.44	4.44	1.41	4.000	4.00	22.88	3.19	5.38	14.50	10.13	15.50	19.44
	2	8.000	14.88	2.50	2.50	24	4.44	4.44	1.41	4.000	4.00	22.88	4.00	6.19	14.50	10.13	16.31	20.25
	3	7.000	14.88	2.50	2.50	24	4.44	4.44	1.41	4.000	4.00	22.88	3.50	5.69	14.50	10.13	15.81	19.75
14.00	1 (std.)	7.000	17.13	2.50	2.50	24	4.88	4.88	1.41	4.500	4.50	26.13	3.50	5.88	15.63	10.88	16.69	20.88
	2	10.000	17.13	2.50	2.50	24	4.88	4.88	1.41	4.500	4.50	26.13	4.50	6.88	15.63	10.88	17.69	21.88
	3	8.000	17.13	2.50	2.50	24	4.88	4.88	1.41	4.500	4.50	26.13	4.00	6.38	15.63	10.88	17.19	21.38

¹NPTF ports are available at no extra charge.

²Optional SAE flange ports may be specified – flange to be supplied by customer. See Optional SAE Flange Port Pattern table for dimensions.

³SAE straight thread ports are standard and are indicated by port number.

Optional SAE Flange Port Pattern

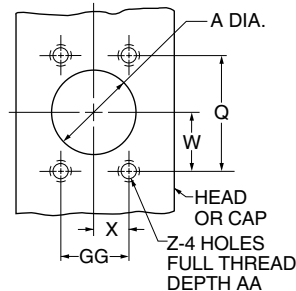

Nom. Flange Size	A	Q	GG	W	X	Z-THD UNC-2B	AA Min.	SAE
2	2.00	3.062	1.688	1.53	0.84	1/2-13	1.06	32
2 1/2	2.50	3.500	2.000	1.75	1.00	1/2-13	1.19	40

Style DB – Maximum Operating Pressure

Bore Ø	psi
10.00	2800
12.00	2350
14.00	2200

Intermediate Fixed Trunnion Mounting

Style DD
(NFA Style MT4)

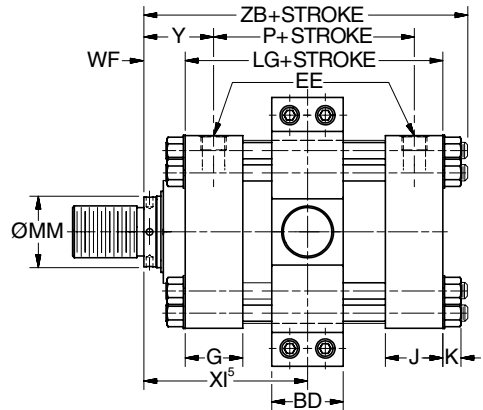
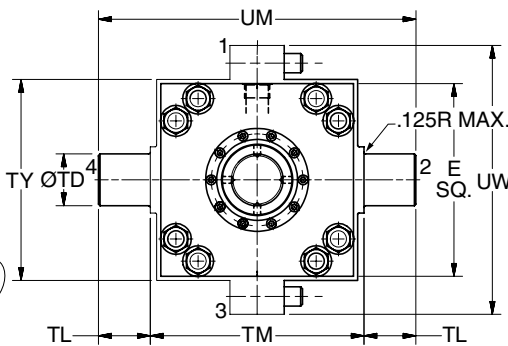
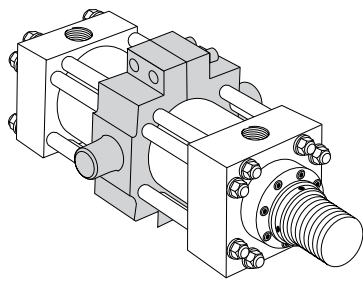

Style DD – Dimensional and Mounting Data

Bore Ø	Rod No.	MM Rod Ø	E	EE Ports			BD	G	J	K	TD Ø +0.000 -0.001	TL	TM	TY	UM	UW	WF	Min. XI ⁵	Y	Add Stroke		
				NPTF ¹	SAE Flge. Port ²	SAE Str. Thr. Port ³														LG	P	ZB Max.
10.00	1 (std.)	4.500	12.63	2.00	2.00	24	4.50	3.69	3.69	1.28	3.500	3.50	14.00	13.00	21.00	17.50	2.94	9.06	4.75	12.13	8.50	16.69
	2	7.000	12.63	2.00	2.00	24	4.50	3.69	3.69	1.28	3.500	3.50	14.00	13.00	21.00	17.50	3.50	9.63	5.31	12.13	8.50	17.25
	3	5.000	12.63	2.00	2.00	24	4.50	3.69	3.69	1.28	3.500	3.50	14.00	13.00	21.00	17.50	3.19	9.31	5.00	12.13	8.50	16.94
	4	5.500	12.63	2.00	2.00	24	4.50	3.69	3.69	1.28	3.500	3.50	14.00	13.00	21.00	17.50	3.19	9.31	5.00	12.13	8.50	16.94
12.00	1 (std.)	5.500	14.88	2.50	2.50	24	5.50	4.44	4.44	1.41	4.000	4.00	16.50	15.50	24.50	20.75	3.19	10.63	5.38	14.50	10.13	19.44
	2	8.000	14.88	2.50	2.50	24	5.50	4.44	4.44	1.41	4.000	4.00	16.50	15.50	24.50	20.75	4.00	11.50	6.19	14.50	10.13	20.25
	3	7.000	14.88	2.50	2.50	24	5.50	4.44	4.44	1.41	4.000	4.00	16.50	15.50	24.50	20.75	3.50	10.94	5.69	14.50	10.13	19.75
14.00	1 (std.)	7.000	17.13	2.50	2.50	24	5.50	4.88	4.88	1.41	4.500	4.50	19.50	19.25	28.50	24.75	3.50	11.44	5.88	15.63	10.88	20.88
	2	10.000	17.13	2.50	2.50	24	5.50	4.88	4.88	1.41	4.500	4.50	19.50	19.25	28.50	24.75	4.50	12.44	6.88	15.63	10.88	21.88
	3	8.000	17.13	2.50	2.50	24	5.50	4.88	4.88	1.41	4.500	4.50	19.50	19.25	28.50	24.75	4.00	11.94	6.38	15.63	10.88	21.38
16.00	1 (std.)	8.000	19.00	3.00	3.00	24	5.50	5.88	5.88	1.91	4.500	4.50	21.50	21.25	30.50	26.75	4.00	12.44	6.88	15.63	10.88	21.38
	3	9.000	19.00	3.00	3.00	24	5.50	5.88	5.88	1.91	4.500	4.50	21.50	21.25	30.50	26.75	4.25	12.94	7.38	15.63	10.88	21.88
	4	10.000	19.00	3.00	3.00	24	5.50	5.88	5.88	1.91	4.500	4.50	21.50	21.25	30.50	26.75	4.50	12.94	7.38	15.63	10.88	21.88
18.00	1 (std.)	9.000	22.00	3.00	3.00	24	6.88	6.88	6.88	1.91	4.500	4.50	24.50	24.25	33.50	29.75	4.25	14.44	7.25	15.13	15.13	27.63
	3	10.000	22.00	3.00	3.00	24	6.88	6.88	6.88	1.91	4.500	4.50	24.50	24.25	33.50	29.75	4.50	14.94	7.75	15.13	15.13	28.13
	4	11.000	22.00	3.00	3.00	24	6.88	6.88	6.88	1.91	4.500	4.50	24.50	24.25	33.50	29.75	4.50	14.94	7.75	15.13	15.13	28.13
20.00	1 (std.)	10.000	24.00	3.00	3.00	24	7.88	7.88	7.88	1.91	4.500	4.50	27.50	27.25	36.50	32.75	4.50	15.94	8.75	17.63	17.63	30.38

¹NPTF ports are available at no extra charge.

²Optional SAE flange ports may be specified – flange to be supplied by customer. See Optional SAE Flange Port Pattern table for dimensions.

³SAE straight thread ports are standard and are indicated by port number.

⁴Consult Factory

⁵Dimension XI to be specified by customer.

Optional SAE Flange Port Pattern

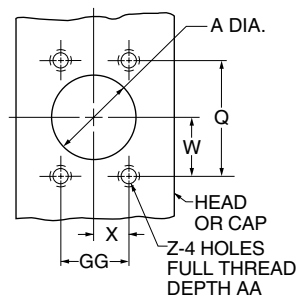

Nom. Flange Size	A	Q	GG	W	X	Z-THD UNC-2B	AA Min.	SAE
2	2.00	3.062	1.688	1.53	0.84	1/2-13	1.06	32
2 1/2	2.50	3.500	2.000	1.75	1.00	1/2-13	1.19	40
3	3.00	4.188	2.438	2.09	1.22	5/8-11	1.19	48

Style DD – Maximum Operating Pressure

Bore Ø	psi
10.00	2800
12.00	2350
14.00	2200



**Double Rod Cylinder
Style K**

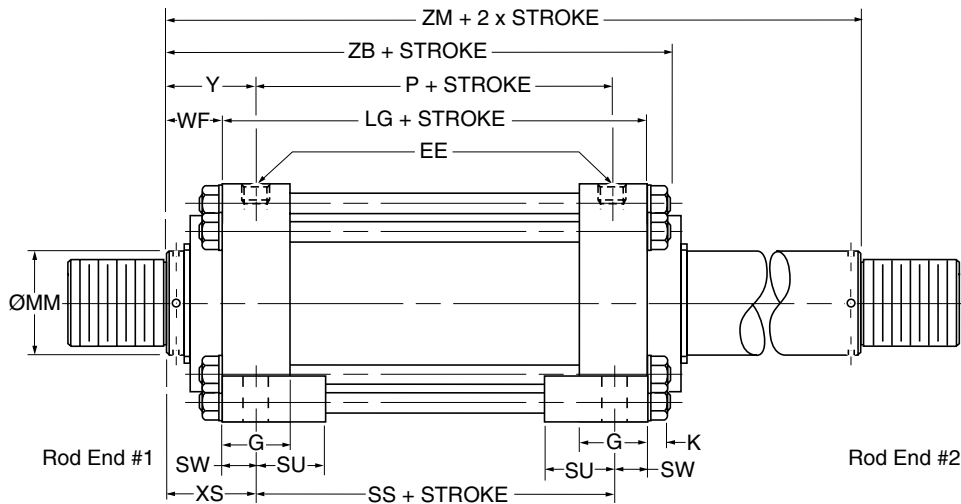

Mounting Styles for Single Rod Models	Mounting Styles for Corresponding Double Rod Models ¹	Dimension Shown on This Page Supplement Dimensions on Pages Listed Below
TB	KTB	53
TD	KTD	53
JJ	KJJ	54/55
JB	KJB	56
C	KC	59
D	KD	61
DD ²	KDD	63

¹If only one end of these Double Rod Cylinders is to be cushioned, be sure to specify clearly which end this will be.

²Specify XI dimension from rod end #1.

Bore Ø	Rod Code	Rod Ø	Add 2X Stroke
			ZM
10.00	1	4.500	18.00
	2	7.000	19.12
	3	5.000	18.50
	4	5.500	18.50
12.00	1	5.500	20.88
	2	8.000	22.50
	3	7.000	21.50
14.00	1	7.000	22.63
	2	10.000	24.63
	3	8.000	23.63
16.00	1	8.000	26.13
	3	9.000	26.63
	4	10.000	27.13
18.00	1	9.000	29.63
	3	10.000	30.13
20.00	1	10.000	32.63

**How to Use Double Rod Cylinder
Dimension Drawings**

To obtain dimensioning information on a double rod cylinder, first select the desired mounting style and refer to the corresponding single rod cylinder model shown on the preceding pages. (See table above.) After you have determined all necessary dimensions from that drawing, turn back to this page and supplement those dimensions with additional ones from the drawing above and table at right. These added dimensions differ from, or are in addition to, those shown on the preceding pages and

provide the additional information needed to completely dimension a double rod cylinder model.

On a double rod cylinder where the two rod ends are different, be sure to clearly state which rod end is to be assembled at which end. Port position 1 is standard. If other than standard, specify pos. 2, 3 or 4 when viewed from rod end #1 only. See port position information in Section E.

Section C

.....

Cylinder Accessories and Replacement Parts

2H & 3H Cylinder Mounting Accessories	66-69
2H Spherical Bearing Mounting Accessories	70
2H & 3H Linear Alignment Couplers	71
Split Couplers and Weld Plates for Style 55 Piston Rod End	73
Dual Axis Knuckle	74
2H Parts List and Seal Kits	76, 77
3H Parts List and Seal Kits for 7.00" & 8.00" Bore	78
Piston Seal Kits for Series 2H with Magnetic Piston Option	79
Gland Cartridge Wrenches	79
3H Parts List and Seal Kits for 10.00" - 20.00" Bore	80, 81
2HD/3HD Parts List and Seal Kits	82



Cylinder Accessories

Parker offers a complete range of cylinder accessories to assure flexibility and versatility in present or future cylinder applications.

Rod End Accessories

Accessories offered for the rod end of the cylinder include: Rod Clevis, Eye Bracket, Knuckle, Clevis Bracket and Pivot Pin. To select the proper part number for any desired accessory, refer to Chart A below and look opposite the thread size of the rod end as indicated in the first column. The Pivot Pins, Eye Brackets and Clevis Brackets are listed opposite the thread size which their mating Knuckles or Clevises fit.



Accessory Load Capacity

The various accessories on this and the following pages have been load rated for your convenience. The load capacity shown in lbs. is the recommended maximum load for that accessory based on a 4:1 design factor in tension. (Pivot Pin is rated in shear.) Before specifying,

compare the actual load or the tension (pull) force at maximum operating pressure of the cylinder with the load capacity of the accessory you plan to use. If load or pull force of cylinder exceeds load capacity of accessory, consult factory.

Chart A

Thread Size	Pin Ø	Rod Clevis		Mounting Plate or Eye Bracket		Pivot Pin	
		Part Number	Load Capacity (lb)	Forged Steel or Cast Ductile Iron		Part Number	Shear Capacity (lb)
				Part Number	Load Capacity (lb)		
5/16-24	0.312	0512210000 ¹	2600	0959810031	1850	—	—
7/16-20	0.500	0509400000	4250	0959810050 ²	4620	0683680000	8600
1/2-20	0.500	0509410000	4900	0959810050 ²	4620	0683680000	8600
3/4-16	0.750	0509420000	11200	0959810075 ²	12370	0683690000	19300
3/4-16	0.750	1332840000	11200	0959810075 ²	12370	0683690000	19300
7/8-14	1.000	0509430000	18800	0959810100 ²	20450	0683700000	34300
1-14	1.000	0509440000	19500	0959810100 ²	20450	0683700000	34300
1-14	1.000	1332850000	19500	0959810100 ²	20450	0683700000	34300
1 1/4-12	1.375	0509450000	33500	0959810138	33500	0683710000	65000
1 1/4-12	1.375	1332860000	33500	0959810138	33500	0683710000	65000
1 1/2-12	1.750	0509460000	45600	0959810175	49480	0683720000	105200
1 3/4-12	2.000	0509470000	65600	0959810200 ²	70100	0683730000	137400
1 7/8-12	2.000	0509480000	65600	0959810200 ²	70100	0683730000	137400
2 1/4-12	2.500	0509490000	98200	0959810250 ²	98200	0683740000	214700
2 1/2-12	3.000	0509500000	98200	0959810300 ²	121940	0683750000	309200
2 3/4-12	3.000	0509510000	98200	0959810300 ²	121940	0683750000	309200
3 1/4-12	3.500	0509520000	156700	0959810350	187910	0735450000	420900
3 1/2-12	4.000	0509530000	193200	0959810400	268000	0735470000	565800
4-12	4.000	0509540000	221200	0959810400	268000	0735470000	565800

¹ Includes pivot pin.

² Cylinder accessory dimensions conform to ANSI/NFPA/T3.6.8 R3-2010.

Mounting Plates

Mounting Plates for Style BB (clevis mounted) cylinders are offered. To select proper part number for your application, refer to Chart B at right.

Chart B

Series 2H		Series 3H	
Mounting Plate Part Number	Bore Ø	Mounting Plate Part Number	Bore Ø
0959810050	1.50	0959810250	7.00
0959810075	2.00, 2.50	0959810300	8.00
0959810100	3.25	0959810350	10.00
0959810138	4.00	0959810400	12.00
0959810175	5.00		
0959810200	6.00		

Rod Clevis Dimensions

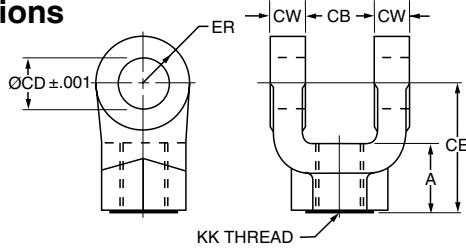

Part Number ¹	Pin \varnothing	A	CB	CD \varnothing	CE	CW	ER	KK Thread
0512210000 ²	0.310	0.81	0.34	0.314	2.25	0.20	0.30	5/16-24
0509400000	0.500	0.75	0.77	0.503	1.50	0.49	0.50	7/16-20
0509410000	0.500	0.75	0.77	0.503	1.50	0.49	0.50	1/2-20
0509420000	0.750	1.13	1.27	0.753	2.13	0.62	0.75	3/4-16
1332840000	0.750	1.13	1.27	0.753	2.38	0.62	0.75	3/4-16
0509430000	1.000	1.63	1.52	1.003	2.94	0.74	1.00	7/8-14
0509440000	1.000	1.63	1.52	1.003	2.94	0.74	1.00	1-14
1332850000	1.000	1.63	1.52	1.003	3.13	0.74	1.00	1-14
0509450000	1.375	1.88	2.04	1.378	3.75	0.99	1.38	1 1/4-12
1332860000	1.375	2.00	2.04	1.378	4.13	0.99	1.38	1 1/4-12
0509460000	1.750	2.25	2.54	1.753	4.50	1.24	1.75	1 1/2-12
0509470000	2.000	3.00	2.54	2.003	5.50	1.24	2.00	1 3/4-12
0509480000	2.000	3.00	2.54	2.003	5.50	1.24	2.00	1 7/8-12
0509490000	2.500	3.50	3.04	2.503	6.50	1.49	2.50	2 1/4-12
0509500000	3.000	3.50	3.04	3.003	6.75	1.49	2.75	2 1/2-12
0509510000	3.000	3.50	3.04	3.003	6.75	1.49	2.75	2 3/4-12
0509520000	3.500	3.50 ³	4.04	3.503	7.75	1.98	3.50	3 1/4-12
0509530000	4.000	4.00 ³	4.54	4.003	8.81	2.23	4.00	3 1/2-12
0509540000	4.000	4.00 ³	4.54	4.003	8.81	2.23	4.00	4-12

Pivot Pin Dimensions

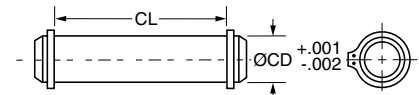

Part Number	CD \varnothing	CL
0683680000	0.500	1.88
0683690000	0.750	2.63
0683700000	1.000	3.13
0683710000	1.375	4.19
0683720000	1.750	5.19
0683730000	2.000	5.19
0683740000	2.500	6.19
0683750000	3.000	6.25
0735450000	3.500	8.25
0735470000 ⁴	4.000	9.00

⁴ This size supplied with cotter pins.

1. Pivot Pins are furnished with Clevis Mounted Cylinders as standard.
2. Pivot Pins are furnished with (2) Retainer Rings.
3. Pivot Pins must be ordered as a separate item if to be used with Knuckles, Rod Clevises, or Clevis Brackets.

¹ Rod Clevises with pin diameters 0.312 thru 1.375 are forged steel. Rod Clevises with 1.750 pin diameter and larger are cast ductile iron.

² Includes Pivot Pin

³ Consult appropriate cylinder rod end dimensions for compatibility.

Forged Steel or Cast Ductile Iron Mounting Plate or Eye Bracket Dimensions⁵

Note: Cast ductile iron eye brackets must not be welded in place.

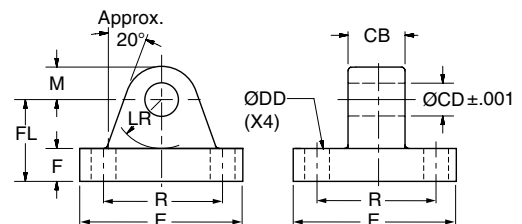

Cast or Forged ⁶ Part Number	Pin \varnothing	CB	CD \varnothing	DD \varnothing	E (As Cast)	F	FL	LR	M (As Cast)	R
0959810031	0.312	0.31	0.314	0.27	2.25	0.38	1.00	0.59	0.38	1.75
0959810050	0.500	0.75	0.503	0.41	2.50	0.38	1.13	0.69	0.50	1.63
0959810075	0.750	1.25	0.753	0.53	3.50	0.63	1.88	1.13	0.75	2.55
0959810100	1.000	1.50	1.003	0.66	4.50	0.88	2.38	1.37	1.00	3.25
0959810138	1.375	2.00	1.378	0.66	5.00	1.00 ⁷	3.00	1.88	1.38	3.82
0959810175	1.750	2.50	1.753	0.91	6.50	1.25 ⁷	3.38	2.13	1.75	4.95
0959810200	2.000	2.50	2.003	1.06	7.50	1.50	4.00	2.38	2.00	5.73
0959810250	2.500	3.00	2.503	1.19	8.50	1.75	4.75	2.88	2.50	6.58
0959810300	3.000	3.00	3.003	1.31	9.50	2.00	5.25	3.13	3.00	7.50
0959810350	3.500	4.00	3.503	1.81	12.63	2.50 ⁸	6.50 ⁸	3.88	3.50	9.62
0959810400	4.000	4.50	4.003	2.06	14.88	3.00 ⁸	7.50 ⁸	4.38	4.06	11.45

⁵ When used to mate with the Rod Clevis, select by pin diameter in the table above.

⁶ Eye Brackets with pin diameters 0.500 thru 1.375 are forged steel. Eye Brackets with 0.312 and 1.750 pin diameter and larger are cast ductile iron.

⁷ These dimensions vary from NFPA standard. F is increased by 0.13. Sufficient LR clearance remains for full swing arc with Parker cap clevis cylinders and rod clevises.

⁸ Mounting base thickness dimension F is increased on these sizes to provide greater load capacity than the former fabricated steel design. Cast ductile iron dimensions F and FL are 0.81 larger for 3.500 pin diameter and 1.06 larger for 4.000 pin diameter.



Rod End Accessories

Accessories offered for the rod end of the cylinder include Rod Clevis, Eye Bracket, Knuckle, Clevis Bracket, and Pivot Pin. To select the proper part number for any desired accessory, refer to the table below or on the opposite page and look in the row to the right of the rod thread in the first column. For economical accessory selection, it is recommended that rod end style 4 be specified on your cylinder order.

Accessory Load Capacity

The various accessories have been load rated for your convenience. The load Capacity in lbs. is the recommended maximum load for that accessory based on a 4:1 design factor in tension. (Pivot Pin is rated in shear.) Before specifying, compare the actual load or the tension (pull) force at the maximum operating pressure of the cylinder with the load capacity of the accessory you plan to use. If load or pull force of cylinder exceeds load capacity of accessory, consult factory.

Thread Size	Pin Ø	Knuckle		Clevis Bracket				Pivot Pin	
		Part Number	Load Capacity (lb)	Forged Steel or Cast Ductile Iron		Fabricated Steel		Part Number	Shear Capacity (lb)
				Part Number	Load Capacity (lb)	Part Number	Load Capacity (lb)		
5/16-24	0.438	0740750000	3300	0960160044	2830	0740760000	3600	0740780000	6600
7/16-20	0.500	0690890000	5000	0960160050	7740	0692050000	7300	0683680000	8600
1/2-20	0.500	0690900000	5700	0960160050	7740	0692050000	7300	0683680000	8600
3/4-16	0.750	0690910000	12100	0960160075	13600	0692060000	10880	0683690000	19300
7/8-14	1.000	0690920000	13000	0960160100	23000	0692070000	15180	0683700000	34300
1-14	1.000	0690930000	21700	0960160100	23000	0692070000	15180	0683700000	34300
1 1/4-12	1.375	0690940000	33500	0960160138	39500	0692080000	23560	0683710000	65000
1 1/2-12	1.750	0690950000	45000	0960160175	49480	0692090000	21520	0683720000	105200
1 3/4-12	2.000	0690960000	53500	0960160200	72400	0692100000	26000	0692150000	137400
1 7/8-12	2.000	0962160000	75000	0960160200	72400	0692100000	26000	0692150000	137400
2 1/4-12	2.500	0962170000	98700	0960160250	98700	0692110000	28710	0683740000	214700
2 1/2-12	3.000	0962180000	110000	0960160300	123300	0692120000	28190	0683750000	309200
2 3/4-12	3.000	0962190000	123300	N/A	N/A	0692130000	31390	0692160000	309200
3 1/4-12	3.500	0962200000	161300	0960160350	200400	0735420000	80250	0735450000	420900
3 1/2-12	3.500	0962210000	217300	0960160350	200400	0735420000	80250	0735450000	420900
4-12	4.000	0962220000	273800	0960160400	292100	0735430000	98420	0821810000	565800
N/A	4.000	N/A	N/A	N/A	N/A	N/A	N/A	0735470000 ¹	565800

¹ This size supplied with cotter pins.

Forged Steel or Cast Ductile Iron Clevis Bracket Dimensions

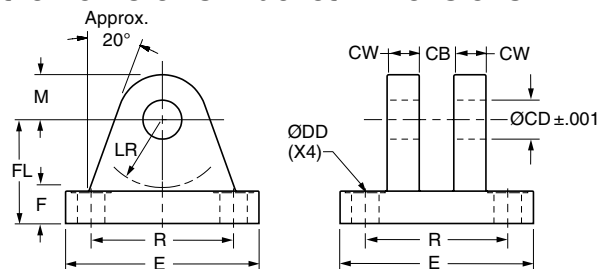

Note: Cast ductile iron clevis brackets must not be welded in place.

Cast or Forged ² Part Number	Pin Ø	CB	CD Ø	CW	DD Ø	E (As Cast)	F	FL	LR	M (As Cast)	R
0960160044	0.438	0.46	0.440	0.37	0.27	2.25	0.38	1.00	0.56	0.44	1.75
0960160050	0.500	0.78	0.503	0.50	0.41	2.50	0.38	1.13	0.63	0.56	1.63
0960160075	0.750	1.28	0.753	0.63	0.53	3.50	0.63	1.88	1.06	0.75	2.56
0960160100	1.000	1.53	1.003	0.75	0.66	4.50	0.75	2.25	1.25	1.00	3.25
0960160138	1.375	2.03	1.378	1.00	0.66	5.00	0.88	3.00	1.94	1.38	3.81
0960160175	1.750	2.53	1.753	1.25	0.91	6.50	0.94	3.13	2.00	1.75	4.94
0960160200	2.000	2.53	2.003	1.25	1.06	7.50	1.38	3.75	2.25	2.00	5.75
0960160250	2.500	3.03	2.503	1.50	1.19	8.50	1.50	4.50	2.81	2.50	6.59
0960160300	3.000	3.03	3.003	1.50	1.31	9.50	1.88	5.38	3.31	3.00	7.50
0960160350	3.500	4.03	3.503	2.00	1.81	12.63	2.31	6.38	3.88	3.50	9.62
0960160400	4.000	4.53	4.003	2.25	2.06	14.88	2.88	7.50	4.50	4.00	11.50

² Clevis Brackets with pin diameters 0.500 thru 1.375 are forged steel. Clevis Brackets with 0.438 and 1.750 pin diameter and larger are cast ductile iron.

Knuckle Dimensions

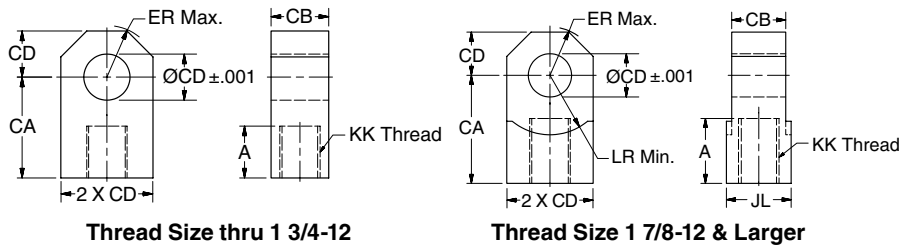

Pivot Pin Dimensions

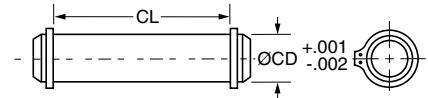

Part Number	Pin Ø	A	CA	CB	CD Ø	ER	JL	LR min	KK Thread
0740750000	0.438	0.75	1.50	0.43	0.440	0.53	-	-	5/16-24
0690890000	0.500	0.75	1.50	0.75	0.503	0.59	-	-	7/16-20
0690900000	0.500	0.75	1.50	0.75	0.503	0.59	-	-	1/2-20
0690910000	0.750	1.13	2.06	1.25	0.753	0.87	-	-	3/4-16
0690920000	1.000	1.13	2.38	1.50	1.003	1.15	-	-	7/8-14
0690930000	1.000	1.63	2.81	1.50	1.003	1.15	-	-	1-14
0690940000	1.375	2.00	3.44	2.00	1.378	1.55	-	-	1 1/4-12
0690950000	1.750	2.25	4.00	2.50	1.753	1.96	-	-	1 1/2-12
0690960000	2.000	2.25	4.38	2.50	2.003	2.24	-	-	1 3/4-12
0962160000	2.000	3.00	5.00	2.50	2.003	2.24	3.00	2.77	1 7/8-12
0962170000	2.500	3.50	5.81	3.00	2.503	2.76	3.50	3.09	2 1/4-12
0962180000	3.000	3.50	6.13	3.00	3.003	3.30	4.00	3.58	2 1/2-12
0962190000	3.000	3.63	6.50	3.50	3.003	3.30	4.00	3.58	2 3/4-12
0962200000	3.500	4.50	7.63	4.00	3.503	3.87	6.00	4.18	3 1/4-12
0962210000	3.500	5.00	7.63	4.00	3.503	3.87	6.00	4.18	3 1/2-12
0962220000	4.000	5.50	9.13	4.50	4.003	4.43	6.00	4.80	4-12

Part Number	CD Ø	CL
0740780000	0.438	1.31
0683680000	0.500	1.88
0683690000	0.750	2.63
0683700000	1.000	3.13
0683710000	1.375	4.19
0683720000	1.750	5.19
0692150000	2.000	5.69
0683740000	2.500	6.19
0683750000	3.000	6.25
0692160000	3.000	6.75
0735450000	3.500	8.25
0821810000	4.000	8.69
0735470000 ¹	4.000	9.00

¹This size supplied with cotter pins.

1. Pivot Pins are furnished with Clevis Mounted Cylinders as standard.
2. Pivot Pins are furnished with (2) Retainer Rings.
3. Pivot Pins must be ordered as a separate item if to be used with Knuckles, Rod Clevises, or Clevis Brackets.

Fabricated Steel Clevis Bracket Dimensions

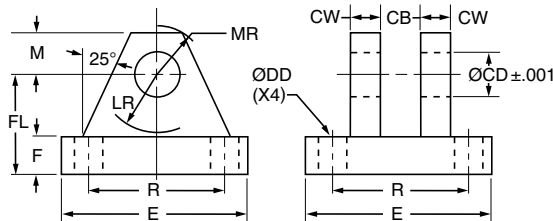

Fabricated Steel Part Number	Pin ² Ø	CB	CD Ø	CW	DD Ø	E	F	FL	LR	M	MR	R
0692050000	0.500	0.80	0.503	0.50	0.41	3.50	0.50	1.50	0.75	0.50	0.63	2.55
0692060000	0.750	1.30	0.753	0.63	0.53	5.00	0.63	1.88	1.19	0.75	0.91	3.82
0692070000	1.000	1.59	1.003	0.75	0.66	6.50	0.75	2.25	1.50	1.00	1.25	4.95
0692080000	1.375	2.09	1.378	1.00	0.66	7.50	0.88	3.00	2.00	1.38	1.66	5.73
0692090000	1.750	2.59	1.753	1.25	0.91	9.50	0.88	3.63	2.75	1.75	2.22	7.50
0692100000	2.000	2.59	2.003	1.50	1.06	12.75	1.00	4.25	3.19	2.25	2.78	9.40
0692110000	2.500	3.09	2.503	1.50	1.19	12.75	1.00	4.50	3.50	2.50	3.13	9.40
0692120000	3.000	3.09	3.003	1.50	1.31	12.75	1.00	6.00	4.25	3.00	3.59	9.40
0692130000	3.000	3.59	3.003	1.50	1.31	12.75	1.00	6.00	4.25	3.00	3.59	9.40
0735420000	3.500	4.09	3.503	2.00	1.81	15.50	1.69	6.69	5.00	3.50	4.13	12.00
0735430000	4.000	4.59	4.003	2.00	2.06	17.50	1.94	7.69	5.75	4.00	4.88	13.75

² Clevis Bracket for 0.438 diameter pin is only available in cast ductile iron construction. See part number 0960160044 on previous page.



Parker offers a complete range of Cylinder Accessories to assure you of the greatest versatility in present or future cylinder applications. Accessories offered for spherical

bearing mount cylinders include the Rod Eye, Pivot Pin and Clevis Bracket. To select the proper part number for any desired accessory refer to the tables below.

Spherical Rod Eye Dimensions

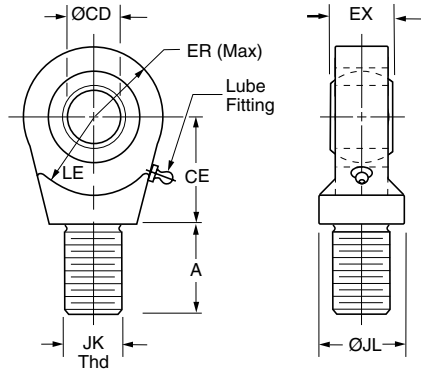

Bore Ø	Part Number	CD Ø	A	CE	EX	ER	LE	JK Thread	JL Ø	Load Capacity (lb)
1.50	0961000050	.5000 ⁻⁰⁰⁰⁵	0.72	0.86	0.44	0.80	0.78	7/16-20	0.88	2644
2.00 & 2.50	0961000075	.7500 ⁻⁰⁰⁰⁵	1.02	1.25	0.66	1.14	1.06	3/4-16	1.31	9441
3.25	0961000100	1.0000 ⁻⁰⁰⁰⁵	1.52	1.88	0.88	1.34	1.45	1-14	1.50	16860
4.00	0961000138	1.3750 ⁻⁰⁰⁰⁵	2.02	2.13	1.19	1.67	1.91	1 1/4-12	2.00	28562
5.00	0961000175	1.7500 ⁻⁰⁰⁰⁵	2.14	2.50	1.53	2.05	2.16	1 1/2-12	2.00	43005
6.00	0961000200	2.0000 ⁻⁰⁰⁰⁵	2.89	2.75	1.75	2.60	2.50	1 7/8-12	2.75	70193

Order to fit Piston Rod Thread Size.

Pivot Pin Dimensions

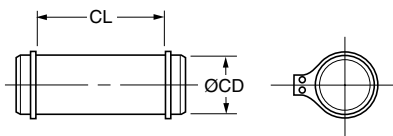

Bore Ø	Part Number	CD Ø	CL	Shear Capacity (lb)
1.50	0839620000	.4997 ⁻⁰⁰⁰⁴	1.56	8600
2.00 & 2.50	0839630000	.7497 ⁻⁰⁰⁰⁵	2.03	19300
3.25	0839640000	.9997 ⁻⁰⁰⁰⁵	2.50	34300
4.00	0839650000	1.3746 ⁻⁰⁰⁰⁶	3.31	65000
5.00	0839660000	1.7496 ⁻⁰⁰⁰⁶	4.22	105200
6.00	0839670000	1.9996 ⁻⁰⁰⁰⁷	4.94	137400

Pivot Pins are furnished with (2) Retainer Rings.

Clevis Bracket Dimensions

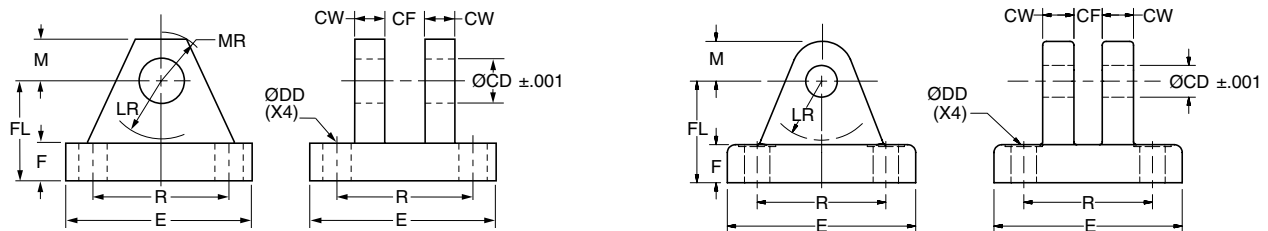

Fabricated Steel

Cast Ductile Iron

Order to fit Cylinder Cap or Rod Eye.

Bore Ø	Pin Ø	Cast Ductile Iron Part Number	Fabricated Steel Part Number	CD Ø	CF	CW	DD Ø	E	F	FL	LR	M	MR	R	Load Capacity (lb)
1.50	0.500	0959450000	0839470000	0.503	0.45	0.50	0.41	3.00	0.50	1.50	0.94	0.50	0.63	2.05	5770
2.00 & 2.50	0.750	0959300000	0839480000	0.753	0.67	0.63	0.53	3.75	0.63	2.00	1.38	0.88	1.00	2.76	9450
3.25	1.000	0959310000	0839490000	1.003	0.89	0.75	0.53	5.50	0.75	2.50	1.69	1.00	1.19	4.10	14300
4.00	1.375	0959320000	0839500000	1.378	1.20	1.00	0.66	6.50	0.88	3.50	2.44	1.38	1.63	4.95	20322
5.00	1.750	0959330000	0839510000	1.753	1.55	1.25	0.91	8.50	1.25	4.50	2.88	1.75	2.06	6.58	37800
6.00	2.000	0959340000	0839520000	2.003	1.77	1.50	0.91	10.63	1.50	5.00	3.00	2.00	2.38	7.92	50375

Linear Alignment Couplers



- Simplify Cylinder Installation
- Reduce Assembly Time
- Increase Cylinder Bearing and Seal Life
- Reliable Performance In “Push” *and* “Pull” Applications

Linear Alignment Couplers are available in 19 standard thread sizes...

Cost Saving Features and Benefits Include...

- Maximum reliability for trouble-free operation, long life and lower operating costs
- Increased cylinder life by reducing wear on Piston and Rod bearings
- Simplifying Cylinder installation and reducing assembly costs
- Increase Rod Bearing and Rod Seal life for lower maintenance costs

Alignment Coupler

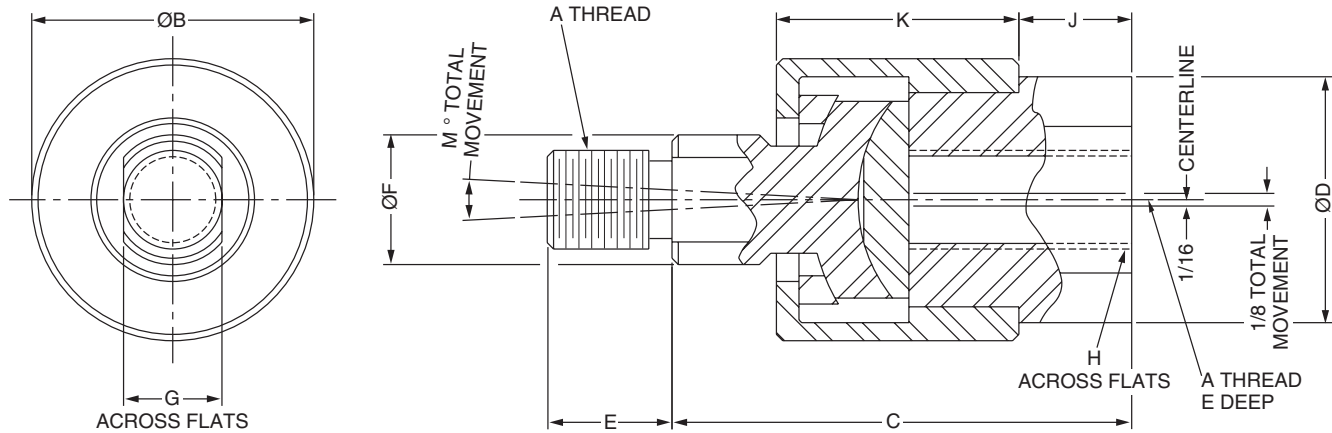

Part Numbers and Dimensions

Part Number	A	B Ø	C	D Ø	E	F Ø	G	H	J	K	M	Max. Pull Load (lbs.)	Max. Approx. Weight (lbs.)
1347570031	5/16-24	1.13	1.75	0.94	0.50	0.50	0.38	0.75	0.38	0.94	6°	1200	.35
1347570038	3/8-24	1.13	1.75	0.94	0.50	0.50	0.38	0.75	0.38	0.94	6°	2425	.35
1347570044	7/16-20	1.38	2.00	1.13	0.75	0.63	0.50	0.88	0.38	1.09	6°	3250	.55
1347570050	1/2-20	1.38	2.00	1.13	0.75	0.63	0.50	0.88	0.38	1.09	6°	4450	.55
1347570063	5/8-18	1.38	2.00	1.13	0.75	0.63	0.50	0.88	0.38	1.09	6°	6800	.55
1347570075	3/4-16	2.00	2.31	1.63	1.13	0.94	0.75	1.31	0.44	1.28	6°	9050	1.4
1347570088	7/8-14	2.00	2.31	1.63	1.13	0.94	0.75	1.31	0.44	1.28	6°	14450	1.4
1347570100	1-14	3.13	3.00	2.38	1.63	1.44	1.25	1.88	0.75	1.78	6°	19425	4.8
1347570125	1 1/4-12	3.13	3.00	2.38	1.63	1.44	1.25	1.88	0.75	1.78	6°	30500	4.8
1337390125	1 1/4-12	3.50	4.00	2.00	2.00	1.50	1.25	1.69	0.75	2.50	10°	30500	6.9
1337390150	1 1/2-12	4.00	4.38	2.25	2.25	1.75	1.50	1.94	0.88	2.75	10°	45750	9.8
1337390175	1 3/4-12	4.00	4.38	2.25	2.25	1.75	1.50	1.94	0.88	2.75	10°	58350	9.8
1337390188	1 7/8-12	5.00	5.63	3.00	3.00	2.25	2.00	2.63	1.38	3.38	10°	67550	19.8
1337390200	2-12	5.00	5.63	3.00	3.00	2.25	2.00	2.63	1.38	3.38	10°	77450	19.8
1337390225	2 1/4-12	6.75	6.38	3.25	3.50	2.75	2.38	2.88	1.63	3.75	10°	99250	35.3
1337390250	2 1/2-12	7.00	6.50	4.00	3.50	3.25	2.88	3.38	1.63	3.88	10°	123750	45.3
1337390275	2 3/4-12	7.00	6.50	4.00	3.50	3.25	2.88	3.38	1.63	3.88	10°	150950	45.3
1337390300	3-12	7.00	6.50	4.00	3.50	3.25	2.88	3.38	1.63	3.88	10°	180850	45.3
1337390325	3 1/4-12	9.25	8.50	5.25	4.50	4.00	3.38	4.50	2.00	5.50	10°	213450	—
1337390425	4 1/4-12	12.88	11.25	7.75	4.50	5.50	4.88	7.00	1.50	8.75	10°	370850	—

How to Order Linear Alignment Couplers — When ordering a cylinder with a threaded male rod end, specify the coupler of equal thread size by part number as listed in Table 1, i.e.; Piston Rod “KK” or “CC” dimension is 3/4" - 16", specify coupler part number 1347570075.

Parker “Style 55” Piston Rod End Split Couplers and Weld Plates

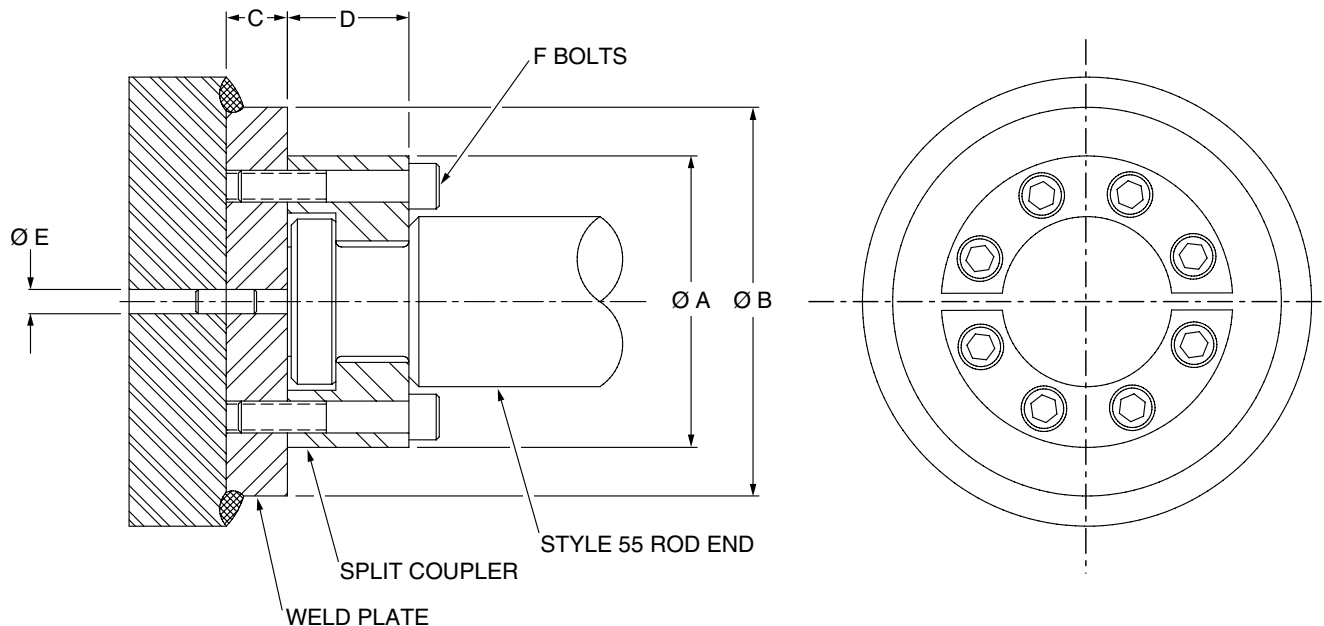

⚠ WARNING: Piston rod separation from the machine member can result in severe personal injury or even death to nearby personnel. The cylinder user must make sure the weld holding the weld plate to the machine is of sufficient quality and size to hold the intended load. The cylinder user must also make sure the bolts holding split coupler to the weld plate are of sufficient strength to hold the intended load and installed in such a way that they will not become loose during the machine's operation.

Part Numbers and Dimensions

Rod Ø	A Ø	B Ø	C	D	E Ø	F	Bolt Size	Bolt Circle	Split Coupler Part Number	Weld Plate Part Number
0.625	1.50	2.00	.50	.56	.250	4	#10-24 x .94 LG	1.125	147234 0062	148174 0062
1.000	2.00	2.50	.50	.88	.250	6	.250-20 x 1.25 LG	1.500	147234 0100	148174 0100
1.375	2.50	3.00	.63	1.00	.250	6	.312-18 x 1.50 LG	2.000	147234 0138	148174 0138
1.750	3.00	4.00	.63	1.25	.250	8	.312-18 x 1.75 LG	2.375	147234 0175	148174 0175
2.000	3.50	4.00	.75	1.63	.375	12	.375-16 x 2.25 LG	2.687	147234 0200	148174 0200
2.500	4.00	4.50	.75	1.88	.375	12	.375-16 x 2.50 LG	3.187	147234 0250	148174 0250
3.000	5.00	5.50	1.00	2.38	.375	12	.500-13 x 3.25 LG	4.000	147234 0300	148174 0300
3.500	5.88	7.00	1.00	2.63	.375	12	.625-11 x 3.50 LG	4.687	147234 0350	148174 0350
4.000	6.38	7.00	1.00	2.63	.375	12	.625-11 x 3.50 LG	5.187	147234 0400	148174 0400
4.500	6.88	8.00	1.00	3.13	.375	12	.625-11 x 4.00 LG	5.687	147234 0450	148174 0450
5.000	7.38	8.00	1.00	3.13	.375	12	.625-11 x 4.00 LG	6.187	147234 0500	148174 0500
5.500	8.25	9.00	1.25	3.88	.375	12	.750-10 x 5.00 LG	6.875	147234 0550	148174 0550
7.000	10.38	11.00	1.75	4.00	.500	12	1.00-8 x 5.50 LG	8.750	147234 0700	148174 0700
8.000	11.38	12.00	2.00	4.00	.500	16	1.00-8 x 5.50 LG	9.750	147234 0800	148174 0800
9.000	13.12	14.00	2.25	4.00	.500	12	1.25-7 x 6.00 LG	11.125	147234 0900	148174 0900
10.000	14.12	15.00	2.50	4.50	.500	16	1.25-7 x 6.50 LG	12.125	147234 1000	148174 1000

Note: Bolts are not included with split coupler or weld plate.



Dual Axis Knuckle

Using a Dual Axis Knuckle permits increased angular movement from the cylinder center line. Clevis or Eye mounted cylinders often require movement beyond the plane that two pivot pins allow. Spherical bearing mounts permit angular movement up to 4.5° within the pivoting plane. A Dual Axis Knuckle, with two pin holes 90° apart, installed at the cap and rod end of a mounting style BB cylinder adds two pivot points, thereby providing up to 30° movement in another plane at each end.

Dual Axis Knuckle Benefits

- Increased angular movement range compared to spherical bearing mount.
- Significantly higher dynamic load rating than spherical bearing mount.
- Reduced bearing loads and wear that results from misalignment.
- Allows faster assembly of pivoting cylinders to the machine.

Maximum Achievable Angular Movement from Cylinder Centerline¹

Inboard Pin -

15° maximum movement for cylinder misalignment only.

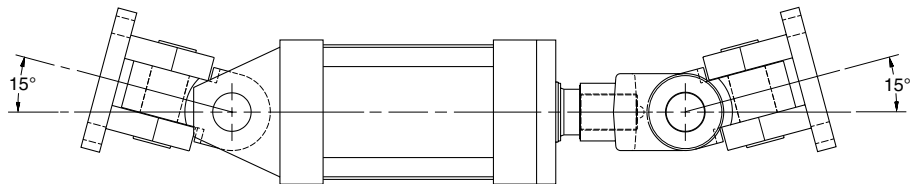

Outboard Pin -

30° maximum movement when applying force to a load moving in a curved plane.

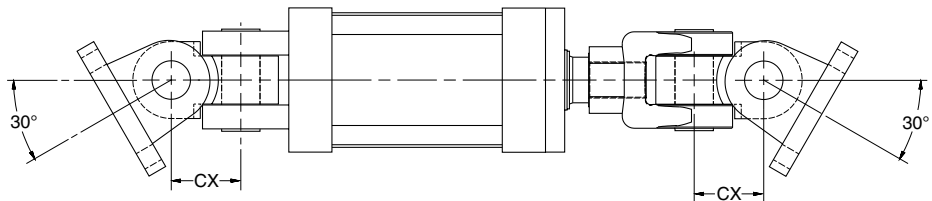

¹ Maximum movement is achieved with cast clevis brackets. Movement is reduced when using fabricated clevis brackets.

Dual Axis Knuckle Dimensions and Usage

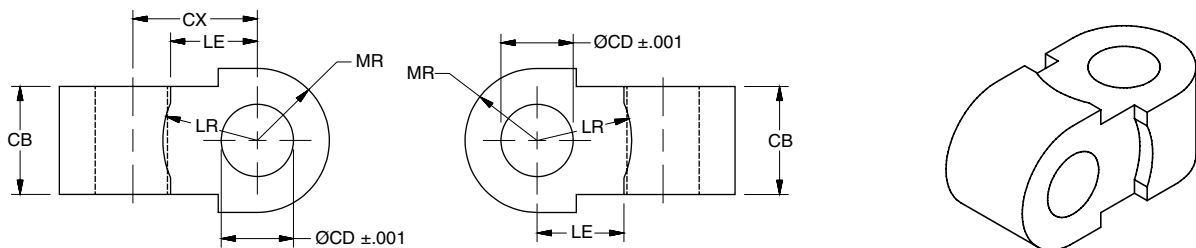

Part Number	Pin Ø	Load Capacity (lb)	CB	CD Ø	CX	LE	LR	MR	Mating Parts		BB Mount Usage by Series & Bore 2H
									Clevis Bracket	Rod Clevis	
0952670000	0.500	4380	0.75	0.503	0.88	0.54	0.63	0.50	0960160050	0509400000, 0509410000	1.50
0952680000	0.750	12370	1.25	0.753	1.19	0.80	0.94	0.75	0960160075	0509420000, 1332840000	2.00, 2.50
0952690000	1.000	20500	1.50	1.003	1.69	1.05	1.22	1.00	0960160100	0509430000, 0509440000, 1332850000	3.25
0952700000	1.375	30500	2.00	1.378	2.38	1.44	1.69	1.38	0960160138	0509450000, 1332860000	4.00
0952710000	1.750	49500	2.50	1.753	3.06	1.81	2.19	1.75	0960160175	0509460000	5.00
0952720000	2.000	68000	2.50	2.003	3.63	2.09	2.44	2.00	0960160200	0509470000, 0509480000	6.00

1.50" - 6.00" Bore Series 2H

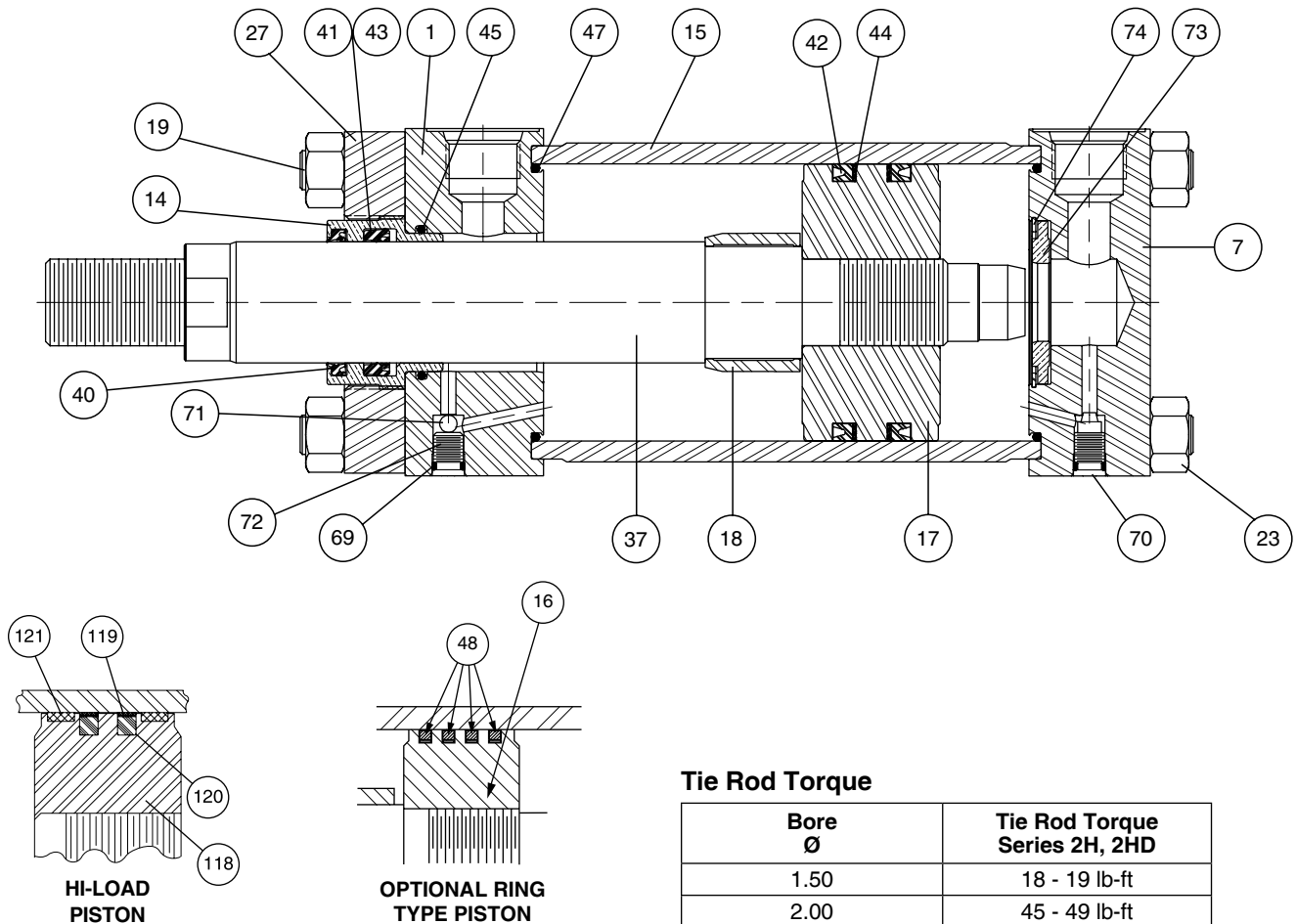

Tie Rod Torque

Bore Ø	Tie Rod Torque Series 2H, 2HD
1.50	18 - 19 lb-ft
2.00	45 - 49 lb-ft
2.50	45 - 49 lb-ft
3.25	120 - 124 lb-ft
4.00	131 - 135 lb-ft
5.00	312 - 316 lb-ft
6.00	528 - 544 lb-ft

Note: The tie rod torque values are for cylinders rated at 3,000 psi. Consult factory for torque values for cylinders rated above 3,000 psi.

Piston and Rod Assemblies

Factory assembled piston and rod assemblies (that include seals for piston type specified) are recommended.

Parts List — 1.50" through 6.00" Bore

Symbol	Description
1	Head
7	Cap
14	Rod Gland
15	Cylinder tube
16	Piston, ring type
17	Piston, lipseal type
18	Cushion plunger, rod head cushion
19	Tie rod
23	Tie rod nut
27	Retainer
37	Piston rod, single rod type
40	Rod Wiper
41	Rod Seal
42	Lipseal, piston
43	Back-up washer, rod seal

Symbol	Description
44	Back-up washer, piston seal
45	Gland O-ring
47	O-ring, cylinder tube to head and cap seal
48	Piston ring, iron
69	O-ring, cushion adjustment and check valve plug screw
70	Needle, cushion adjustment valve
71	Ball, cushion check valve
72	Plug screw, cushion check valve
73	Bushing, float check, cushion on cap end
74	Retaining ring, float check cushion bushing
118	Piston, Hi-Load type
119	Outer Ring
120	Inner Ring
121	Wear Ring

1.50" - 6.00" Bore Series 2H

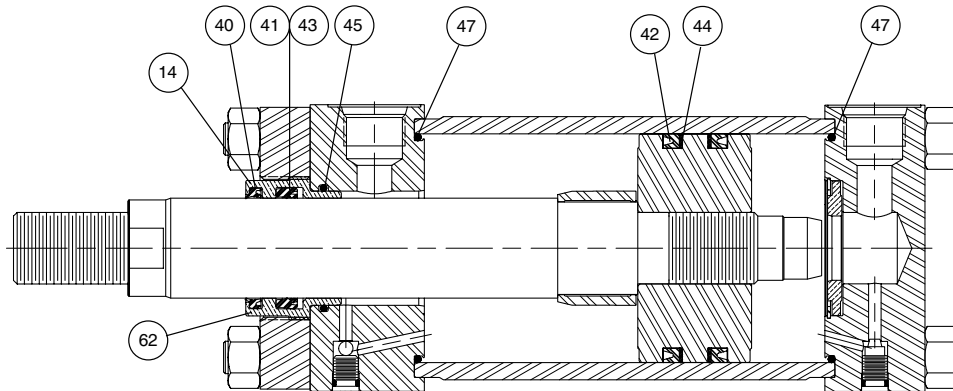

Symbol	Description
14	Rod Gland
40	Rod Wiper
41	Rod Seal
42	Piston Lipseal
43	Rod Seal Back-up Washer
44	Piston Seal Back-up Washer
45	Gland to head o-ring
47	End seal o-ring
48	Piston ring
62	Rod Gland Kit ¹
119	Outer Ring
120	Inner Ring
121	Wear Ring

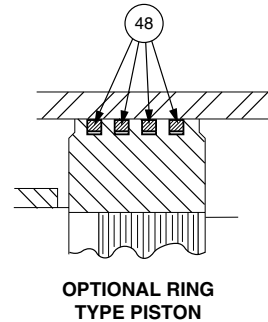
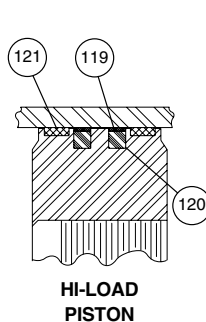

¹Gland Cartridge Kit contains: 14, 40, 41, 43 and 45.

Retainer Bolt Torque for Cylinders with Round Gland Retainers

Torque values are for bolts installed with lubrication.

Bolt Size	Torque
#10	56 - 58 lb-in
1/4	11 - 12 lb-ft
5/16	23 - 24 lb-ft
3/8	41 - 43 lb-ft
7/16	65 - 68 lb-ft

Piston Seal Kits and Body Seal Kits Series 2H

Bore Ø	Class 1 & 2 Service ²			
	Piston Seal Type ³			Body Seal Kits ⁴
	Piston Lipseal Kits ⁴	Piston Ring Kits ⁴	Hi-Load Piston Seal Kits ⁴	
	Series 2H, 3H	Series 2H, 3H	Series 2H, 3H	Series 2H, 3H
1.50	PK152HLL01	PR152H0001	PK152HK001	CB152HL001
2.00	PK202HLL01	PR202H0001	PK202HK001	CB202HL001
2.50	PK252HLL01	PR252H0001	PK252HK001	CB252HL001
3.25	PK322HLL01	PR322H0001	PK322HK001	CB322HL001
4.00	PK402HLL01	PR402H0001	PK402HK001	CB402HL001
5.00	PK502HLL01	PR502H0001	PK502HK001	CB502HL001
6.00	PK602HLL01	PR602H0001	PK602HK001	CB602HL001

² Rod gland cartridge kit & rod seal kit part numbers shown identify class 2 seals. To order class 5 or 6 seals substitute 5 or 6 as required for the last digit of the kit number.

³ Contents and Part Numbers of Seal Kits for Pistons & Bodies

Piston Lipseal Kits – (includes cylinder body end seals) contains two each of items 47, 42, & 44.

Piston Ring Kits – (includes cylinder body end seals) contains qty. 4 of item 48 and qty. 2 of 47.

Hi Load Piston Seal Kits – (includes cylinder body end seals) contains qty. 2 of 119, 120, 121 and 47. Piston seal kit & body seal kit part numbers shown identify class 1 & 2 seals. To order class 5 or 6 seals substitute 5 or 6 as required for the last digit of the kit number.

⁴ Piston seal kit & body seal kit part numbers shown identify class 1 & 2 seals. To order class 5 or 6 seals substitute 5 or 6 as required for the last digit of the kit number.

Service Kit Numbers – Gland Cartridge Kits and Rod Seal Kits – Series 2H

Rod Ø	Seal Type			
	Class 1 Service (Polyurethane & Nitrile)		Class 2 Service ² (Nitrile)	
	Gland Cartridge Kits ⁵	Rod Seal Kits ⁵	Gland Cartridge Kits ⁵	Rod Seal Kits ⁵
0.625	RG2HLTS061	RK2HLTS061	RG2AHL0061	RK2AHL0061
1.000	RG2HLTS101	RK2HLTS101	RG2AHL0101	RK2AHL0101
1.375	RG2HLTS131	RK2HLTS131	RG2AHL0131	RK2AHL0131
1.750	RG2HLTS171	RK2HLTS171	RG2AHL0171	RK2AHL0171
2.000	RG2HLTS201	RK2HLTS201	RG2AHL0201	RK2AHL0201
2.500	RG2HLTS251	RK2HLTS251	RG2AHL0251	RK2AHL0251
3.000	RG2HLTS301	RK2HLTS301	RG2AHL0301	RK2AHL0301
3.500	RG2HLTS351	RK2HLTS351	RG2AHL0351	RK2AHL0351
4.000	RG2HLTS401	RK2HLTS401	RG2AHL0401	RK2AHL0401

⁵ Gland Cartridge Kits contain items 14, 40, 41, 45 (43 class 2, 5 & 6 only). Rod Seal Kits contain items 40, 41, 45 (43 class 2, 5 & 6 only).



7.00" & 8.00" Bore Series 3H

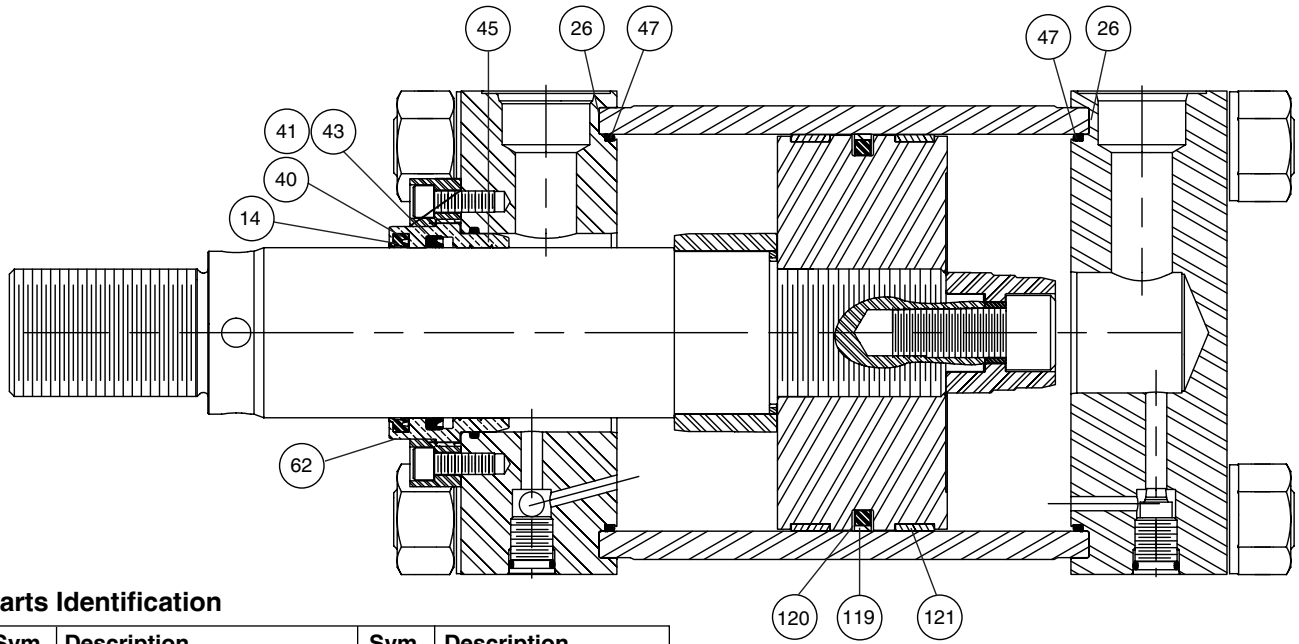

Parts Identification

Sym. No.	Description	Sym. No.	Description
14	Rod Gland	47	End Seal O-Ring
40	Rod Wiper	48	Piston Ring
41	Rod Seal	62	Rod Gland Kit ¹
43	Rod Seal Back Up Washer	119	Outer Ring
26	End Seal Back Up Washer	120	Inner Ring
45	Rod Gland to Head O-Ring	121	Wear Ring

¹Rod Gland Kit contains 14, 40, 41, 43 and 45.

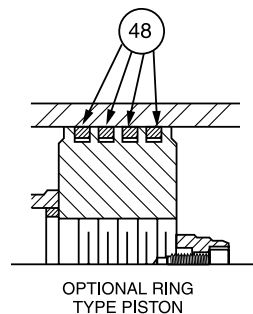

Class 1 Hydraulic Service Only²

Rod. Ø	Gland Cartridge Kits (Sym. #62)	Rod Seal Kits
	Class 1 (Std.)	Class 1 (Std.)
	Buna-N (Nitrile) & Polyurethane	Buna-N (Nitrile) & Polyurethane
3.000	RG2HLTS301	RK2HLTS301
3.500	RG2HLTS351	RK2HLTS351
4.000	RG2HLTS401	RK2HLTS401
4.500	RG2HLTS451	RK2HLTS451
5.000	RG2HLTS501	RK2HLTS501
5.500	RG2HLTS551	RK2HLTS551

²For other classes of service, refer to Bulletin 1110-M3.

Bore Ø	Cylinder Body Seal Kit	Piston Seal Kits ³		Tie Rod Torque 7.00 & 8.00
	CB	PR	Hi-Load	
	Includes 2 ea. Symbol 47 & 26	Includes 2 ea. Sym. 47 & 26; 4 ea. Sym. 48	Includes 2 ea. Sym. 26, 47 & 121; 1 ea. Sym. 119 & 120	
7.00	CB703H0001	PR703H0001	PK703HK001	800-816 lb-ft
8.00	CB803H0001	PR803H0001	PK803HK001	1168-1184 lb-ft

³CB, PR & hi-load piston seal kit part numbers shown identify class 1, 2 & 6 service only. To order Class 5 seals substitute 5 for the last digit of kit number.

Retainer Bolt Torque for Cylinders with Round Gland Retainers

Torque values are for bolts installed with lubrication.

Bolt Size	Torque
#10	56 - 58 lb-in
1/4	11 - 12 lb-ft
5/16	23 - 24 lb-ft
3/8	41 - 43 lb-ft
7/16	65 - 68 lb-ft

Piston Seal Kits for Series 2H with Magnetic Piston Option

Bore Ø	Piston Seal Kit ¹ for Magnetic Piston	
	Class 1 Service	Class 5 Service
1.50	PK152HM001	PK152HM005
2.00	PK202HM001	PK202HM005
2.50	PK252HM001	PK252HM005
3.25	PK322HM001	PK322HM005
4.00	PK402HM001	PK402HM005
5.00	PK502HM001	PK502HM005
6.00	PK602HM001	PK602HM005

¹ Kit includes 1 piece each of bi-directional piston seal, piston seal energizer o-ring, piston wear band and 2 pieces each of cylinder tube to head and cap o-ring seal.

Gland Cartridge Wrenches

Parker's exclusive gland cartridge design makes gland replacement only a minute's work...and the Gland Cartridge Wrench Set makes it even simpler. A specially designed face-type gland wrench with flared lugs slips into an exact, sure fit on the gland, while a self-locking spanner wrench grips the gland wrench securely. No fumbling for adjustment – no accidental scoring of the piston rod, the job is done quickly...easily...safely.

You can order the Cartridge Wrench or Spanner Wrench to fit the piston rod size used in your Parker Hannifin Cylinder.

Rod Ø	Gland Wrench (Symbol 63)	Spanner Wrench (Symbol 63-A)
0.625	0695900000	0116760000
1.000	0695910000	
1.375	0695920000	0117030000
1.750	0695930000	0116770000
2.000	0695940000	
2.500	0695950000	0116770000
3.000	0695960000	
3.500	0695970000	
4.000	0695980000	0116780000
4.500	0838770000	
5.000	0695990000	
5.500	0696000000	

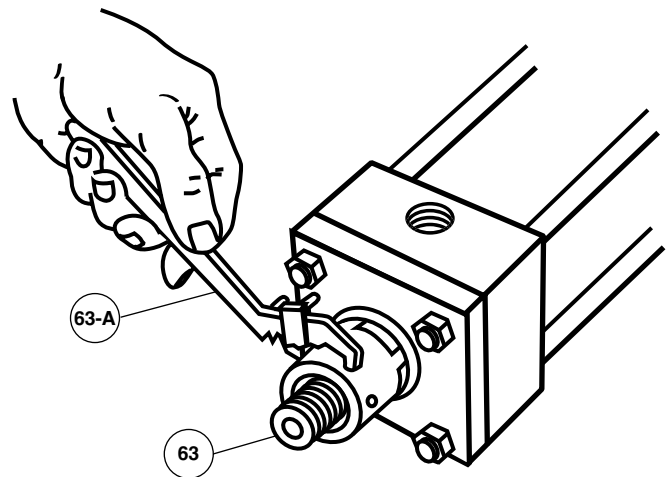

10.00" - 20.00" Bore Series 3H

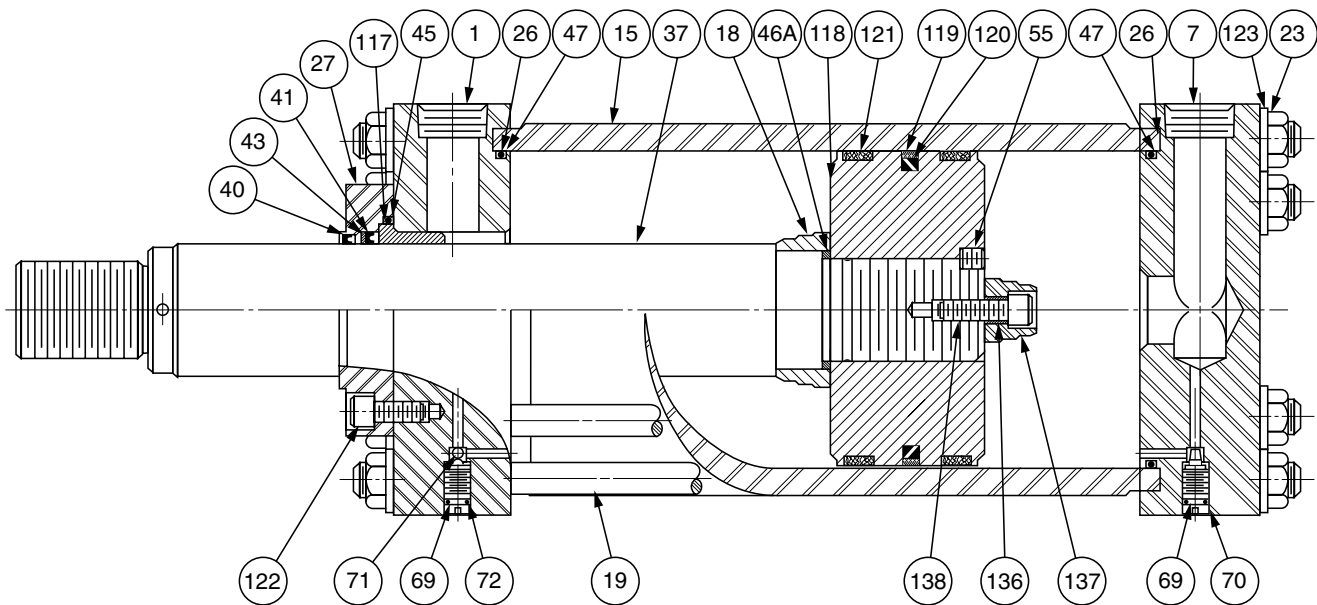

Sym. No.	
1	Head
7	Cap
16	Piston Tube – Ring Type Piston
17	Lipseal Piston
18	Cushion Sleeve
19	Tie Rod
23	Tie Rod Nut – Non-Locking
26	Back-Up Washer, Cylinder Tube
27	Retainer
37	Piston Rod
40	Wiperseal
41	Rod Seal (Polypak)
42	Lipseal Back-Up Washer
43	Back-Up Washer, Polypak
44	Piston Lipseal
45	O-Ring, Gland to Head
46A	Cushion Sealing Ring

Sym. No.	
47	O-Ring Cylinder Tube
48	Piston Ring
55	Piston Lock Pin
69	O-Ring, Cushion Adj. & Check Screws
70	Cushion Adjusting Needle Screw
71	Check Valve Ball
72	Check Valve Screw
117	Rod Bearing (Gland)
118	Piston – Hi-Load
119	Outer Piston Ring
120	Inner Piston Ring
121	Wear Ring
122	Retainer Bolt
123	Washer, Tie Rod Nut
136	Spacer, Cushion
137	Cushion Spear, Detachable
138	Bolt, Cushion Spear

10.00" - 20.00" Bore Series 3H

Optional Piston Lipseal Kit

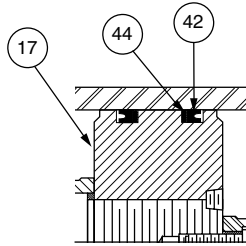

Optional Cast Iron Piston Ring Kit

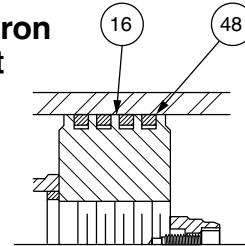

3H Large Bore Seal Kits

Bore Ø	Rod Dia.	Rod Seal Kits		Rod Seal Kits Including Bearing	
		Contains Symbol 40, 41, 43, 45		Contains Symbol 40, 41, 43, 45 & 117	
		Group 1 Kit No.	Group 5 Kit No.	Group 1 Kit No.	Group 5 Kit No.
10.00	4.500	RK3H000451	RK3H000455	RG3H000451	RG3H000455
	7.000	RK3H000701	RK3H000705	RG3H000701	RG3H000705
	5.000	RK3H000501	RK3H000505	RG3H000501	RG3H000505
	5.500	RK3H000551	RK3H000555	RG3H000551	RG3H000555
12.00	5.500	RK3H000551	RK3H000555	RG3H000551	RG3H000555
	8.000	RK3H000801	RK3H000805	RG3H000801	RG3H000805
	7.000	RK3H000701	RK3H000705	RG3H000701	RG3H000705
14.00	7.000	RK3H000701	RK3H000705	RG3H000701	RG3H000705
	10.000 ¹	RK3H001001	RK3H001005	RG3H001001	RG3H001005
	8.000 ¹	RK3H000801	RK3H000805	RG3H000801	RG3H000805

Bore Ø	Tie Rod Torque
10.00	700 - 716 lb-ft
12.00	1320 - 1336 lb-ft
14.00	1000 - 1016 lb-ft
16/18/20	2900 - 3000 lb-ft

Retainer Bolt Torque for Cylinders with Round Gland Retainers

Torque values are for bolts installed with lubrication.

Bolt Size	Torque
1/2	100 - 105 lb-ft
5/8	185 - 194 lb-ft
3/4	330 - 346 lb-ft

¹For 16.00", 18.00" and 20.00" Bore 3H Cylinders with 8.000" and 10.000" rods use the seal kits listed above for 14.00" Bore 3H with 8.000" and 10.000" rods.

3H Piston Ring & Piston Lipseal Kits

Bore Ø	Piston Ring Kit		Piston Lip Seal Kit	
	Contains 2 ea. Symbol # 26 & 47, & 4 ea. Symbol # 48		Contains Symbol # 40, 41, 43, 45 & 117	
	Service Class 1	Service Class 5	Service Class 1	Service Class 5
10.00	PR9023H001	PR9023H005	PK9023H001	PK9023H005
12.00	PR9223H001	PR9223H005	PK9223H001	PK9223H005
14.00	PR9423H001	PR9423H005	PK9423H001	PK9423H005

3H Hi Load Piston Seal Kits

Bore Ø	Hi Load Piston Seal Kit		Cylinder Body End Seal Kit	
			Contains 2 ea. Symbol # 26 & 47	
	Service Class 1	Service Class 5	Service Class 1	Service Class 5
10.00	PK903HK001	PK903HK005	CB9023H001	CB9023H005
12.00	PK923HK001	PK923HK005	CB9223H001	CB9223H005
14.00	PK943HK001	PK943HK005	CB9423H001	CB9423H005
16.00	PK963HK001	PK963HK005	CB9623H001	CB9623H005
18.00	PK983HK001	PK983HK005	CB9823H001	CB9823H005
20.00	PK9A3HK001	PK9A3HK005	CB9A23H001	CB9A23H005



1.50" - 6.00" Bore Series 2HD

7.00" & 8.00" Bore Series 3HD

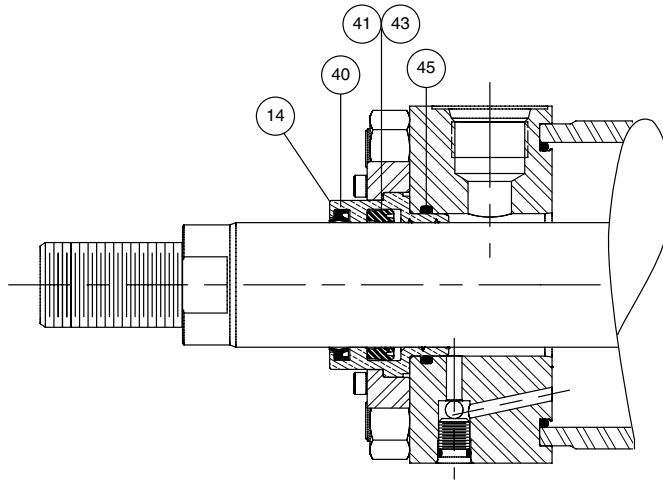

Symbol Number	Description
14	Rod Gland
40	Rod Wiperseal
41	Rod Seal
43	Rod Seal Back-up Washer
45	Gland to Head O-Ring

Rod Gland and Rod Seal Kits for 2HD & 3HD Option Cylinders

Rod Ø	Class 1 Polyurethane & Buna-N		Class 5 Fluorocarbon		Retainer Bolt Torque (Torque values are for bolts installed with lubrication.)
	Rod Gland Kits (Contains: 1 Each Sym. #14, 40, 41, & 45)	Rod Seal Kits (Contains: 1 Each Sym. #40, 41, & 45)	Rod Gland Kits (Contains: 1 Each Sym. #14, 40, 41, 43 ¹ , 45)	Rod Seal Kits (Contains: 1 Each Sym. #40, 41, 43 ¹ , & 45)	
0.625	RG2HDL0061	RK2HDL0061	RG2HDL0065	RK2HDL0065	56 - 58 lb-in
1.000	RG2HDL0101	RK2HDL0101	RG2HDL0105	RK2HDL0105	56 - 58 lb-in
1.375	RG2HDL0131	RK2HDL0131	RG2HDL0135	RK2HDL0135	56 - 58 lb-in
1.750	RG2HDL0171	RK2HDL0171	RG2HDL0175	RK2HDL0175	56 - 58 lb-in
2.000	RG2HDL0201	RK2HDL0201	RG2HDL0205	RK2HDL0205	11 - 12 lb-ft
2.500	RG2HDL0251	RK2HDL0251	RG2HDL0255	RK2HDL0255	11 - 12 lb-ft
3.000	RG2HDL0301	RK2HDL0301	RG2HDL0305	RK2HDL0305	41 - 43 lb-ft
3.500	RG2HDL0351	RK2HDL0351	RG2HDL0355	RK2HDL0355	41 - 43 lb-ft
4.000	RG2HDL0401	RK2HDL0401	RG2HDL0405	RK2HDL0405	41 - 43 lb-ft
4.500	RG2HDL0451	RK2HDL0451	RG2HDL0455	RK2HDL0455	41 - 43 lb-ft
5.000	RG2HDL0501	RK2HDL0501	RG2HDL0505	RK2HDL0505	41 - 43 lb-ft
5.500	RG2HDL0551	RK2HDL0551	RG2HDL0555	RK2HDL0555	41 - 43 lb-ft

Parker Crown Wiper™ Rod Gland and Rod Seal Kits for 2HD & 3HD Option Cylinders

Rod Ø	Class 1 Polyurethane & Buna-N		Class 5 Fluorocarbon		Retainer Bolt Torque (Torque values are for bolts installed with lubrication.)
	Rod Gland Kits (Contains: 1 Each Sym. #14, 40, 41, & 45)	Rod Seal Kits (Contains: 1 Each Sym. #40, 41, & 45)	Rod Gland Kits (Contains: 1 Each Sym. #14, 40, 41, 43 ¹ , & 45)	Rod Seal Kits (Contains: 1 Each Sym. #40, 41, 43 ¹ , & 45)	
0.625	RGCW2HD061	RKCW2HD061	RGCW2HD065	RKCW2HD065	56 - 58 lb-in
1.000	RGCW2HD101	RKCW2HD101	RGCW2HD105	RKCW2HD105	56 - 58 lb-in
1.375	RGCW2HD131	RKCW2HD131	RGCW2HD135	RKCW2HD135	56 - 58 lb-in
1.750	RGCW2HD171	RKCW2HD171	RGCW2HD175	RKCW2HD175	56 - 58 lb-in
2.000	RGCW2HD201	RKCW2HD201	RGCW2HD205	RKCW2HD205	11 - 12 lb-ft
2.500	RGCW2HD251	RKCW2HD251	RGCW2HD255	RKCW2HD255	11 - 12 lb-ft
3.000	RGCW2HD301	RKCW2HD301	RGCW2HD305	RKCW2HD305	41 - 43 lb-ft
3.500	RGCW2HD351	RKCW2HD351	RGCW2HD355	RKCW2HD355	41 - 43 lb-ft
4.000	RGCW2HD401	RKCW2HD401	RGCW2HD405	RKCW2HD405	41 - 43 lb-ft
4.500	RGCW2HD451	RKCW2HD451	RGCW2HD455	RKCW2HD455	41 - 43 lb-ft
5.000	RGCW2HD501	RKCW2HD501	RGCW2HD505	RKCW2HD505	41 - 43 lb-ft
5.500	RGCW2HD551	RKCW2HD551	RGCW2HD555	RKCW2HD555	41 - 43 lb-ft

¹ Item 43 not required for 0.625" and 1.000" rod diameter.

Section D

.....

Series 2H / 3H Custom Modifications

Water Submersible Options	84, 85
Hi Load Piston	86, 87
Low Friction Seals	88, 89
Common Modifications:	
Metallic Rod Wiper	90
Parker Crown Wiper™	90
Rod End Boots	90
Gland Drain	90
Air Bleed Ports	90
Tie Rod Supports	91
Stroke Adjusters	91
Thrust Key Mountings	91
Metric Piston Rod Thread	91
End of Stroke Proximity Switches	92-95



Water Submersible Option for Series 2H and 3H Hydraulic Cylinders

Optional Polypak Inner and Outer Rod Seals resist internal and external pressure. Required for depths over 25 ft and up to 5000 ft.

Optional Dual Cylinder Body Seals resist external pressure. Required for depths over 25 ft and up to 5000 ft.

Optional 17-4 stainless steel tie rods and Bumax 88 stainless steel nuts resist corrosion.

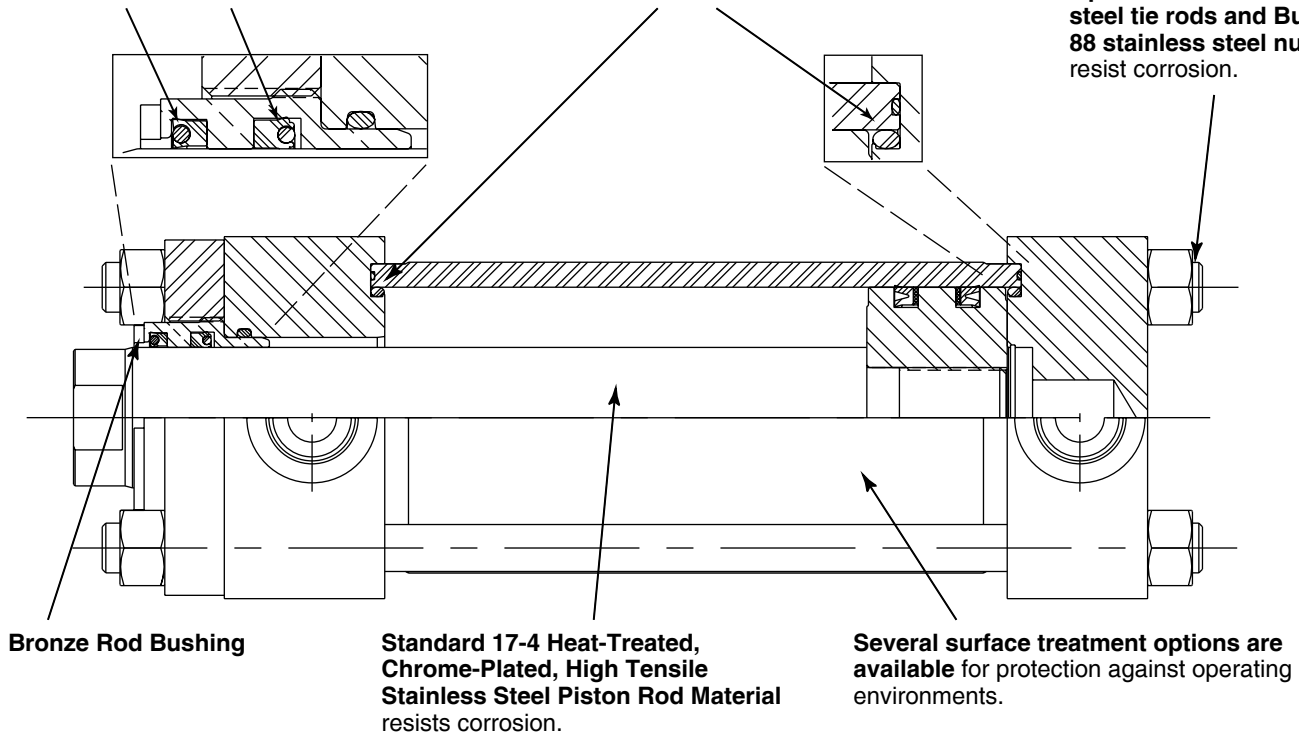

Specifications:

- Submersion Depth: up to 5000 ft
- Heavy Duty Service – ANSI (NFPA) T3.6.7R2 – 1996 Specifications and Mounting Dimension Standards
- Nominal Pressure – 3000 psi
- Operating Temperature – -10°F to +165°F
- 17-4 PH chrome plated stainless steel piston rod
- Stainless steel name tag affixed with stainless steel wire around tie rod

Cylinder Seal Construction:

- Up to 25 ft – Standard rod seal and body seals
- Over 25 ft to 5000 ft
 - Subsea rod seal package that includes a Polypak oil seal and an outward facing Polypak wiper to seal against water intrusion.
 - Subsea body seal package with ID oil seal and body-end o-ring to seal against water intrusion.
 - Not available with 0.625 Ø piston rod

Standard Options for Water Submersible Cylinders:

Material

- 17-4 PH stainless steel tie rods and Bumax 88 stainless steel tie rod nuts
- Chrome plated body ID

Surface Treatments for Corrosion Protection

- Electroless nickel plated exterior (head, cap, body and retainer)
- Inorganic zinc primer (zinc primer only – without bond coating)
- Inorganic zinc primer with epoxy undercoat and anacrylic topcoat
- Epoxy undercoat and topcoat

Custom Options available for Special Order:

- End-of-Stroke Switches
- All stainless steel construction

Water Submersible Option for Series 2H and 3H Hydraulic Cylinders

How to order:

1. Specify the complete Parker Cylinder Model Number.
2. Put an "S" in the model number to indicate a special cylinder.
3. Include the 3 digit Submersible Code.
4. For custom options, such as switches, provide a complete description or drawing of your requirements.

Submersible Code

When selecting the submersible option, an S must be placed in the Model Number. Select Submersible Code values for the required Submersion Depth, Cylinder Body, and Corrosion Protection. See the example Model Number below:

Feature	Code	Specification	For
Submersion Depth	1	Conventional rod gland and body seal design	Depths to 25 ft
	2	Submersible rod gland & dual cylinder body seals	Depths to 5000 ft
	3	Other	Specify depth / requirements
Cylinder Body	P	Plain ID	
	C	Chrome plated ID	
Corrosion Protection	1	Inorganic zinc primer	Splash & short term immersion service where equipment is top coated by the customer
	2	Inorganic zinc primer with stainless steel tie rods, nuts, & fasteners	
	3	Electroless nickel plated exterior with stainless steel tie rods, nuts, & fasteners	
	4	Inorganic zinc primer, epoxy undercoat, & anacrylic topcoat.	Splash & short term immersion service
	5	Inorganic zinc primer, epoxy undercoat, & anacrylic topcoat with stainless steel tie rods, nuts, & fasteners	
	6	Epoxy base & top coat.	
	7	Epoxy base & top coat. with stainless steel tie rods, nuts, & fasteners	Long term immersion service
9	Other	Specify requirements	

Example:

4.00 BB 2HK T S 14 X 24.00

S=Submersible Code: 2P1

(describes a 4" x 24" cylinder for submersion up to 5000 ft, with a plain cylinder body ID and Inorganic Zinc Primer corrosion protection.)

Water Submersible Codes and Features Supplied

Depths to 5000 ft¹

Submersible Cylinder Feature	Water Submersible Code ¹													
	2P1	2P2	2P3	2P4	2P5	2P6	2P7	2C1	2C2	2C3	2C4	2C5	2C6	2C7
17-4 PH piston rod	X	X	X	X	X	X	X	X	X	X	X	X	X	X
Stainless steel tag	X	X	X	X	X	X	X	X	X	X	X	X	X	X
Submersible rod gland	X	X	X	X	X	X	X	X	X	X	X	X	X	X
Dual cylinder body seals	X	X	X	X	X	X	X	X	X	X	X	X	X	X
Chrome plated cylinder ID								X	X	X	X	X	X	X
SS tie rods, nuts, & fasteners		X	X		X		X		X	X		X		X
Electroless nickel plated exterior			X							X				
Inorganic zinc primer	X	X						X	X					
Inorganic zinc primer with topcoats				X	X						X	X		
Epoxy base & topcoat						X	X						X	X

¹ Corresponding submersible codes for depths to 25 ft begin with 1 (e.g. 1P1, 1P2, etc.) and include all of the features marked for 5000 ft depth **except** Submersible Rod Gland and Dual Cylinder Body Seals.



The Exclusive Parker Hi Load Piston

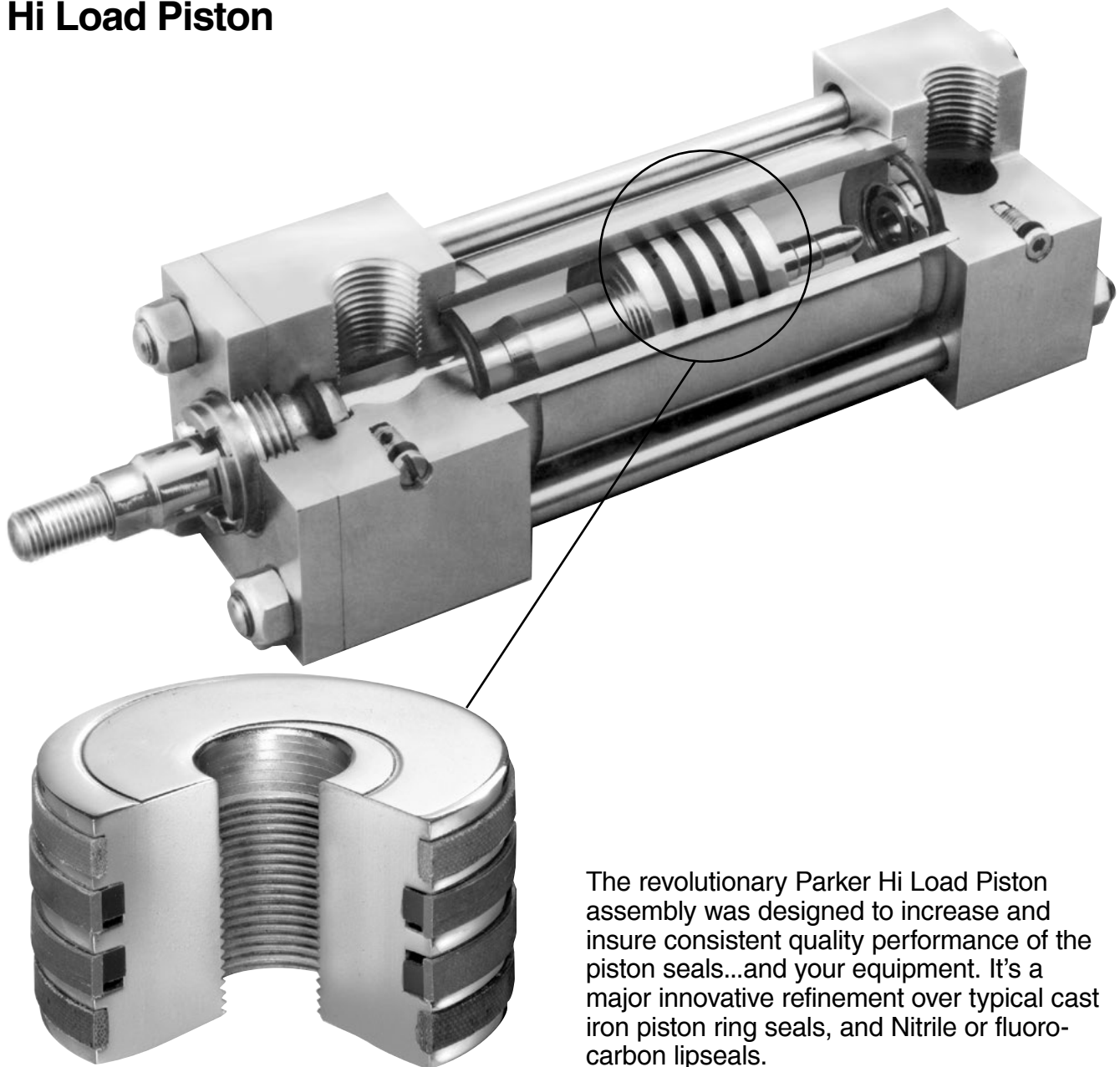

- Virtually eliminates leakage
- Hi Load capacity
- High contamination tolerance
- Long life
- Low friction
- Standard on Series 3H cylinders

The revolutionary Parker Hi Load Piston assembly was designed to increase and insure consistent quality performance of the piston seals...and your equipment. It's a major innovative refinement over typical cast iron piston ring seals, and Nitrile or fluoro-carbon lipseals.

The Hi Load piston assembly overcomes the inherent problems commonly associated with these conventional types of seals, such as scoring of the cylinder bore due to contamination, and it virtually eliminates leakage flow. It can also reduce or eliminate the need for stop tubing. It has much greater side load carrying capacity, and most importantly, even at pressures up to 3,000 psi, it has a longer wearing life than any seal we have tested to date.

The Exclusive Parker Hi Load Piston

The effective difference... Parker's bronze-filled PTFE ring design.

The Hi Load piston assembly is comprised of two square-cut bronze-filled PTFE piston rings (A) with Nitrile rubber expanders underneath (B) and two non-metallic wear rings (C) which uniquely work together, incorporating the best qualities of both elements to achieve dramatic efficiency.

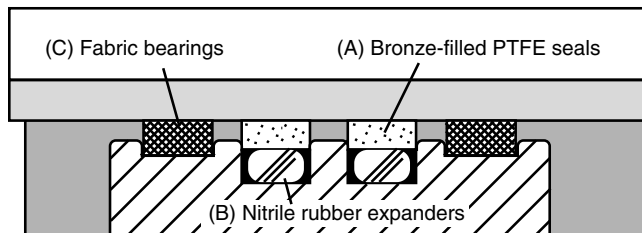

Reduced scoring. Low friction. The non-metallic wear rings eliminate all metal-to-metal contact between the piston and cylinder body. Some scoring may occur even with the use of compatible materials such as cast iron or bronze for the piston and steel for the cylinder body. The combination of the high imbeddability factor and the wiping action of the wear rings prevent contamination from getting between the piston bearing and sealing surfaces, therefore, scoring is greatly reduced. This also contributes to the extended life of the bronze-filled PTFE rings. Other benefits of the Hi Load piston are excellent lubricity and minimum wear when using water-based fluids, soluble oil and water and biodegradable fluids.

Extensive controlled contamination tests in our laboratory have shown the Hi Load piston to operate more than **4 times longer** than lip seals when high degrees of contamination are present.

Note: Because the Hi Load piston prevents metal-to-metal contact with the cylinder bore, steel pistons may be used which are stronger than other types.

Higher side load carrying capacity. Under severe side load conditions such as long stroke or pivot mounted cylinders the characteristics of non-metallic wear rings provides increased side load carrying capability, which is another distinctive benefit. Non-metallic bearings can also absorb shock, and with increased side load can give and thus conform more to piston and cylinder body. The action of deformation increases the area of contact, which in turn keeps the contact stresses from increasing and permits the Hi Load piston to have a higher side load carrying capacity. This can often reduce or eliminate the need for stop tubing.

Comparative Piston Seal Friction

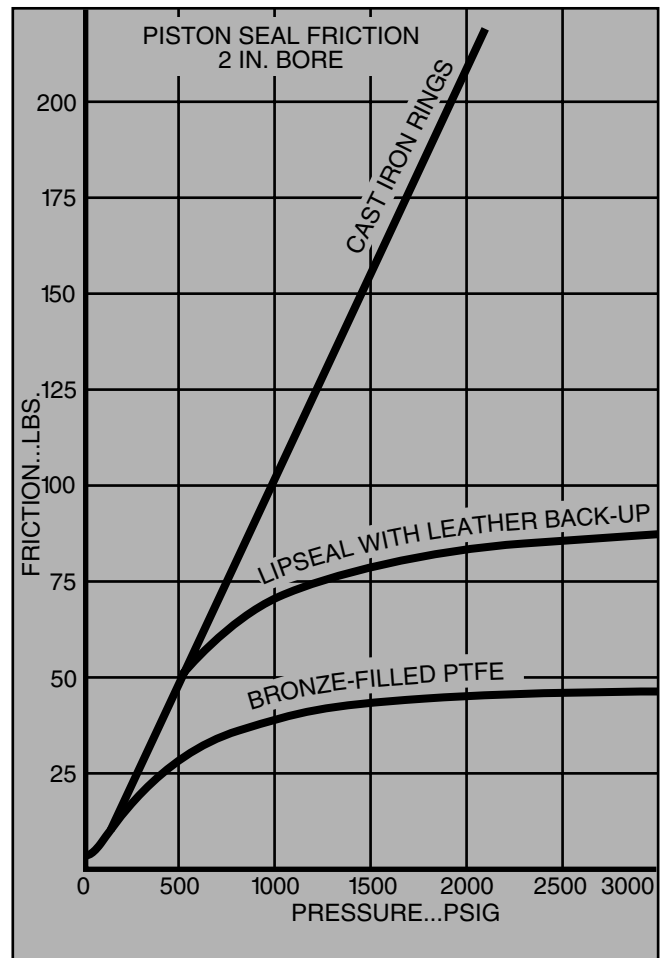

Virtually zero leakage. The Hi Load piston assembly means virtually zero leakage with hydraulic and/or water base fluids because of the continuous bronze-filled PTFE rings with a homogenous inner ring of Nitrile rubber to apply seal preloading. The Nitrile expanders provide enough initial radial force to eliminate low pressure leakage. At higher pressure (above 2,000 psi) the seals are pressurized underneath, and are therefore dynamically self-sealing just as cast iron rings are.

The bronze-filled PTFE resists extrusion in the clearance between the piston much better than Nitrile, and, as a result, provides at least double the life, increasing life spans as pressure goes up.

When ordering the Hi Load piston option for Series 2H cylinders, please specify K in the piston seal field of the model code. The Hi Load piston is standard on all Series 3H cylinders.

Parker Series 2H/3H Hydraulic Cylinders with Low Friction Seal Option

High Performance Cylinders for Your Demanding Applications

- Smooth-running operation – reduces “slip-stick” or “chatter”
- Ideally suited for use in servo applications
- Bronze-filled PTFE material for low friction, rapid break-in and long service life
- Innovative seal geometry for maximum sealing efficiency

Low Friction Rod Gland

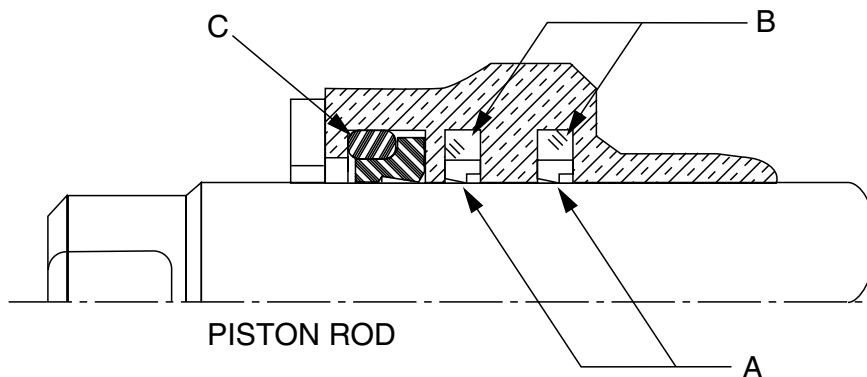

A - Dual step-seal rod seals ensure positive sealing and smooth operation up to 3,000 psi.

B - Square ring elastomer expander for pressure compensation and low pressure effectiveness.

C - Energized filled PTFE wiper keeps contaminants out.

D - Available in 1.000", 1.375", 1.750", 2.000", 2.500", 3.000", 3.500", 4.000", 4.500", 5.000", 5.500" diameter piston rods (1.50" - 8.00" Bore).

Low Friction Piston

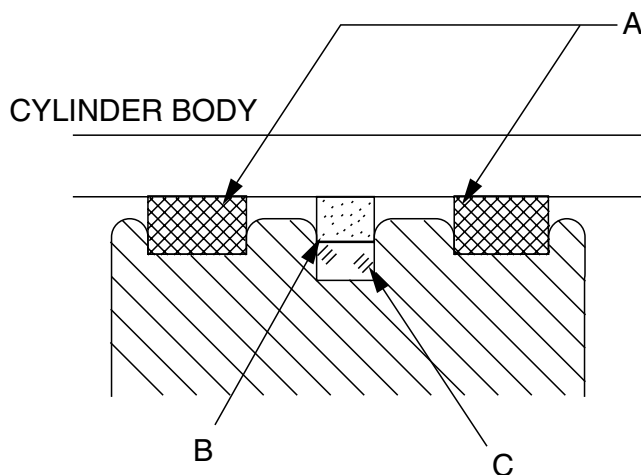

A - Dual bronze-filled PTFE piston bearings for high load capacity, low friction and no metal-to-metal contact.

B - Bronze filled PTFE piston seal ensures maximum sealing efficiency.

C - Square-ring elastomer expander for pressure compensation

D - Available in 1.50" - 8.00" bore diameters

Seal Friction:

Seal friction under a given set of working conditions is not easily calculated due to the multiplicity of variables involved. The following graphs are offered as a guide for use in performance calculations, but for critical application measurements should be made under simulated or actual working conditions.

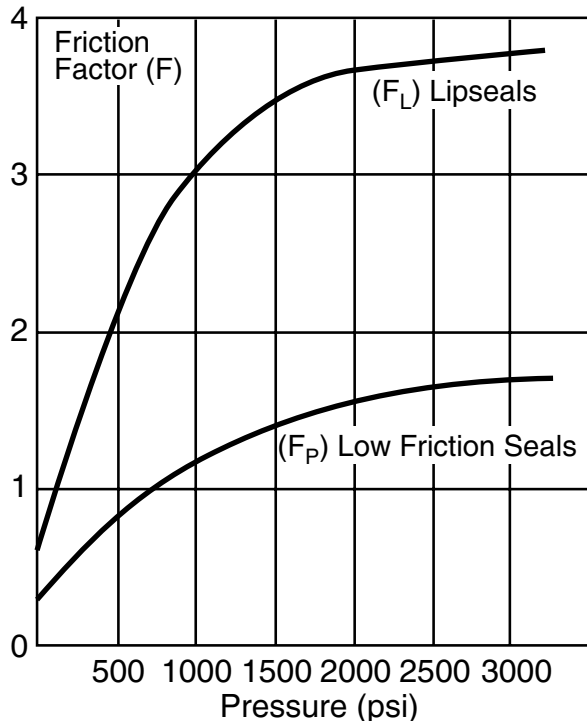

Calculation of Running Friction:

The seal friction attributable to the cylinder is calculated as the sum of the friction due to the individual sealing elements = (wiper seal friction + rod seal friction + piston seal friction), using the following formulae:

Option:	Formula:
Lipseal Rod + Piston	$12d + 12 F_L d + 24 F_L D$
Lipseal Rod w/Low Friction Piston	$12d + 12 F_L d + 12 F_p D$
Low Friction Rod + Piston	$12d + 30 F_p d + 6 F_p D$

Where: d = rod dia. (in.) D = bore dia. (in.)
 F_L = friction factor for lipsels (F_L)
 F_p = friction factor for PTFE (F_p)

Breakaway Friction:

Breakaway friction may be calculated by applying the following correction factors:

Correction factors:
 Lipsels: $F_L \times 1.5$
 Low Friction: $F_p \times 1.0$

Sample Calculation:

2HX Cylinder with 3.25 dia. bore + 1.75 dia. piston rod with low friction seals at 1500 psi.

Running Friction Calculation:

$$\text{Friction (lbs. force)} \approx 12d + 30F_p d + 6F_p D$$

$$\text{Friction (lbs. force)} \approx 12 (1.75) + 30 (1.3 \times 1.75) + 6 (1.3 \times 3.25)$$

$$\text{Friction (lbs. force)} \approx 115$$

Breakaway Friction Calculation:

$$F_p \times 1.0 \approx F_p$$

Based on zero pressure:

$$\text{Friction (lbs. force)} \approx 12d + 30F_p d + 6F_p D$$

$$\text{Friction (lbs. force)} \approx 12 (1.75) + 30 (.3 \times 1.75) + 6 (.3 \times 3.25)$$

$$\text{Friction (lbs. force)} \approx 43$$

Specifications for Low Friction Options:

Operating Pressure: 0 - 3000 psi

Operating Temperature: -10°F to +160°F.
 For higher temperatures, consult factory.

Fluid Media: Petroleum based hydraulic oils.
 For other fluids, consult factory.

How to Order Low Friction Option for Series 2H/3H Cylinders

When ordering Series 2H or 3H cylinders, place an "F" in the piston field for low friction seals.

Consult factory for availability of gland drain or other options.



Modifications: The following modifications can be supplied on most Parker cylinders.

Metallic Rod Wiper

When specified metallic rod wipers can be supplied instead of the standard synthetic rubber wiperseal. Recommended in applications where contaminants tend to cling to the extended piston rod and would damage the synthetic rubber wiperseal. Installation of metallic rod wiper does not affect cylinder dimensions. It is available at extra cost.

Parker Crown Wiper™ for Series 2HD and 7" & 8" bore 3HD

For environments that contain fine abrasive particulate specify the Crown Wiper option. The Crown Wiper is a proven superior alternative to piston rod end boots or metallic wipers that can ingest particulate. It has a sharp leading edge to effectively clean the piston rod and a beveled shape to prevent contaminant intrusion by channeling it away from the gland. It also acts as a secondary seal to wipe clean any oil film adhering to the rod on the extend stroke.

Standard Crown Wiper material for Seal Class 1 and 2 service is durable polyurethane. Optional FKM material is available for Class 5 service. The Crown Wiper requires a unique gland but does not change cylinder mounting dimensions

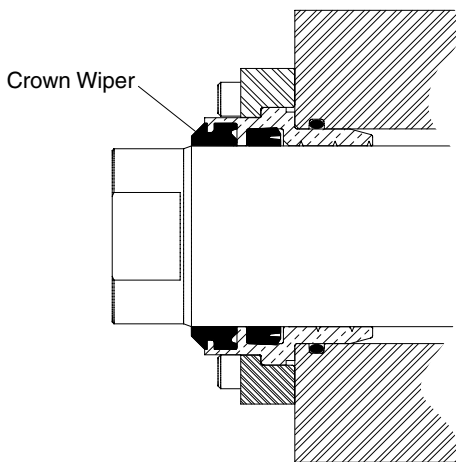

Crown Wiper Rod Gland Kits are available to retrofit existing 2HD & 3HD cylinders. See 2HD/3HD Parts List and Seal Kits page.

Rod End Boots

Cylinders have a hardened bearing surface on the piston rod to resist external damage, and are equipped with the high efficiency "Wiperseal" to remove external dust and dirt. Exposed piston rods that are subjected to contaminants with air hardening properties, such as paint, should be protected. In such applications, the use of a collapsing cover should be considered. This is commonly referred to as a "boot". Calculate the longer rod end required to accommodate the collapsed length of the boot from the following data.

LF	.13	.13	.13	.13	.13	.13	.13	.10	.10	.10	.10	.10
OD	2.25	2.25	2.63	3.00	3.38	3.75	4.38	5.13	5.63	6.25	7.00	7.50
MM	.500	.625	1.000	1.380	1.750	2.000	2.500	3.000	3.500	4.000	5.000	5.500

To determine extra length of piston rod required to accommodate boot, calculate

$BL = \text{Stroke} \times LF + 1.13"$

$BL + \text{Std. W} + A = \text{length of piston rod to extend beyond the retainer.}$

NOTE: Check all Boot O.D's against std. "E" dimension from catalog. This may be critical on foot mounted cylinders.

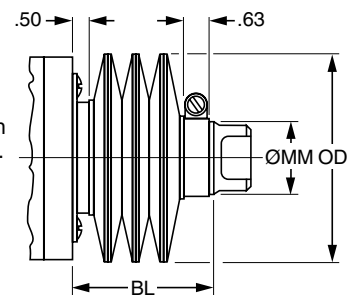

Gland Drain

Hydraulic fluids tend to adhere to the piston rods, during the extend stroke, and an accumulation of fluid can collect in the cavity behind the gland wiperseal on long stroke cylinders.

A 1/8" NPTF gland drain port can be provided in the gland retainer. A passage in the gland between the wiperseal and lipseal is provided to drain off any accumulation of fluid between the seals. See drawing below.

It is recommended that the gland drain port be piped back to the fluid reservoir and that the reservoir be located below the level of the head of the cylinder.

On 1.50" bore with 0.625" rod the drain port is located in the head adjacent to the port. The retainer thickness on 1.50" bore with 1.000" rod and gland drain is increased to 0.63".

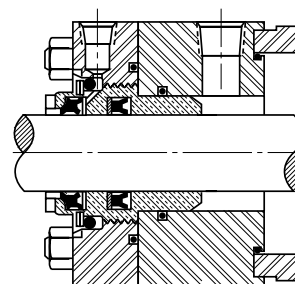

On 2.00"-8.00" bore sizes the drain port is located in the retainer as shown. On Style JJ with gland drain and 1.000"-4.000" rods the retainer thickness is increased by 0.25".

Air Bleeds

In most hydraulic circuits, cylinders are considered self-bleeding when cycled full stroke. If air bleeds are required and specified, 1/8" NPTF Air Bleed Ports for venting air can be provided at both ends of the cylinder body, or on the head or cap. To order, specify "Bleed Port", and indicate position desired.

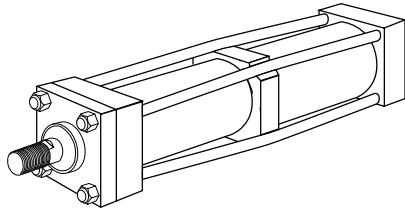

Tie Rod Supports

Rigidity of Envelope – The pre-stressed tie rod construction of Parker cylinders has advantages in rigidity within the limits of the cylinder tube to resist buckling. For long stroke cylinders within practical limits. Parker provides exclusive TIE ROD SUPPORTS (see table below) which move the tie rod centerlines radially outward.

Standard tie rod supports are kept within the envelope dimensions of the head and cap, and generally do not interfere with mounting a long cylinder.

Number of Supports Required	Bore Ø	Stroke (Inches)												
		36	48	60	72	84	96	108	120	132	144	156	168	
	1.00	—	1	1	1	2	Consult Factory							
	1.50	—	—	1	1	1	2	2	2	3	3	3	4	
	2.00	—	—	—	1	1	1	1	2	2	2	2	3	
	2.50	—	—	—	—	—	1	1	1	1	1	2	2	
	3.25	—	—	—	—	—	—	—	1	1	1	1	1	
	4.00	—	—	—	—	—	—	—	—	—	1	1	1	

Note: 5.00" through 14.00" bore sizes — no supports required.

Stroke Adjusters

For the requirement where adjusting the stroke is specified. Parker has several designs to offer, one of which is illustrated below. This is suitable for infrequent adjustment and is economical¹.

Bore Ø Series 2H & 3H	D	J	K	L (Max.)
1.50	1/2 - 20	0.31	0.94	5
2.00	3/4 - 16	0.44	1.25	8
2.50, 3.25	1 - 14	0.63	1.69	9
4.00	1 1/2 - 12	0.94	2.13	18
5.00	2 - 12	0.94	2.69	20
6.00	2 1/2 - 12	1.69	3.13	20
7.00	3 - 12	2.00	3.25	20
8.00	3 1/2 - 12	2.38	3.50	20

Here a "retracting stroke adjuster" must be called for in specifications, and the length of the adjustment must be specified.

Where frequent adjustment or cushions at the cap end are required, other designs are available according to application needs.

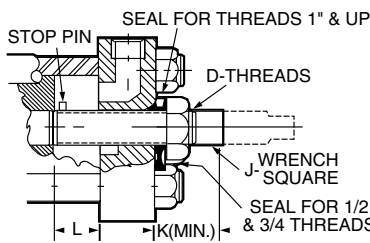

¹ Infrequent is defined by positioning the retract stroke in a couple of attempts at original machine set up. The frequent stroke adjuster is recommended for adjustments required after the original equipment has been adjusted by the original machine manufacturer.

Thrust Key Mountings (2H, 3H, 2HD, 3HD)

Thrust key mountings eliminate the need of using fitted bolts or external keys on side mounted cylinders. Parker cylinders in mounting styles CP and FP can be provided with the gland retainer plate extended below the mounting side of the cylinder (see illustration below). This extended retainer plate can then be fitted into a keyway milled into the mounting surface of the machine member. This is referred to as the "P" Modification of any side mounting style.

Note: Please consult factory when replacing HD Series cylinders.

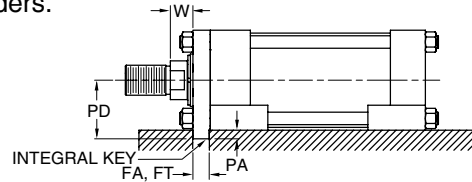

Bore Ø	FA (Series 2HD/3HD)	FT (Series 2H/3H)	PA	PD Mtg. Styles CP & FP
1.50	.361 -0.001 +0.000	.312 -0.002 +0.000	0.19	1.44
2.00	.611 -0.001 +0.000	.562 -0.002 +0.000	0.31	1.81
2.50	.611 -0.001 +0.000	.562 -0.002 +0.000	0.31	2.06
3.25	.736 -0.001 +0.000	.687 -0.003 +0.000	0.38	2.63
4.00	.861 -0.001 +0.000	.812 -0.003 +0.000	0.44	2.94
5.00	.861 -0.001 +0.000	.812 -0.003 +0.000	0.44	3.69
6.00	.986 -0.001 +0.000	.937 -0.003 +0.000	0.50	4.25
7.00	.986 -0.001 +0.000	.937 -0.003 +0.000	0.50	4.75
8.00	.986 -0.001 +0.000	.937 -0.003 +0.000	0.50	5.25

Metric Piston Rod Thread

The table below lists the standard thread supplied when Piston Rod Thread type M is specified in the cylinder model code.

MM Rod Ø	Thread		A
	Styles 4M & 9M KK	Style 8M CC	
0.625	M10x1.5	M12x1.5	0.75
1.000	M20x1.5	M22x1.5	1.13
1.375	M26x1.5	M30x2	1.63
1.750	M33x2	M39x2	2.00
2.000	M39x2	M45x2	2.25
2.500	M48x2	M56x2	3.00
3.000	M58x2	M68x2	3.50
3.500	M64x2	M76x2	3.50
4.000	M76x2	M95x2	4.00
4.500	M80x2	M110x2	4.50
5.000	M90x2	M110x2	5.00
5.500	M100x2	M130x2	5.50
7.000	M125x4	-	7.00
8.000	M140x4	-	8.00
9.000	M160x4	-	9.00
10.000	M180x4	-	10.00



Cylinder End-of-Stroke Proximity Switches



“EPS” Style Inductive Sensors
For General Industrial AC and DC Applications

“CLS” Style Magnetic Sensors
Including Extreme Temperature Applications

All Sensors Are:
Non-Contacting
Water Resistant
Weld-Field Immune
Shock and Vibration Resistant
Flange-Mounted to Cylinder End Caps

**EPS 7 & 6 Sensors
Inductive Proximity**

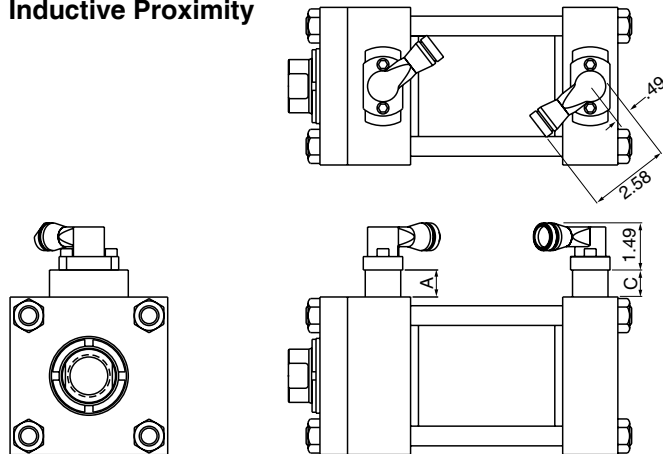

**CLS 1 & 4 Sensors
Non-Contacting
Magnetically
Actuated**

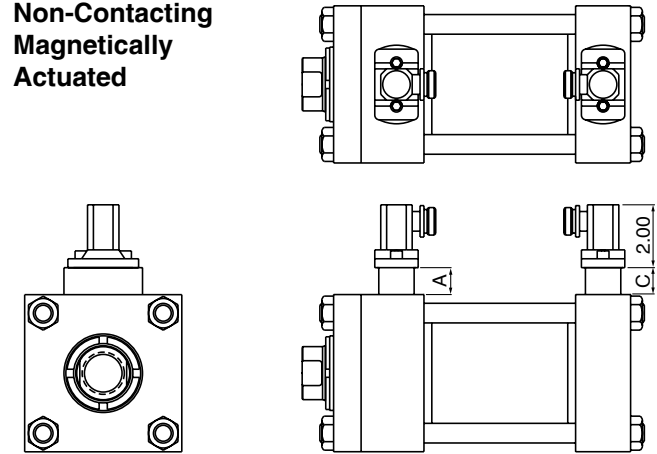

**Spacer Height
EPS & CLS Sensors**

A max.	C max.
.86	1.75

For exact dimensions, see Bulletin 0840-G-E1.

Connector Pin Numbering

3-Pin Mini

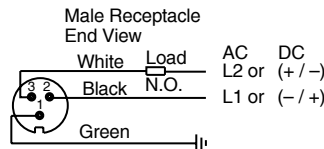

EPS-7

5-Pin Mini

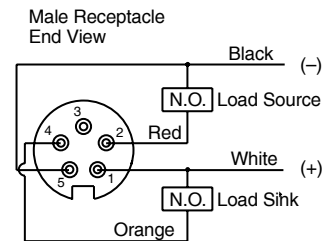

EPS-6

Series and Parallel Wiring

When Parker EPS-6 or 7 sensors are used as inputs to programmable controllers the preferred practice is to connect each sensor to a separate input channel of the PLC. Series or parallel operations may then be accomplished by the internal PLC programming.

Parker EPS-6 or 7 sensors may be hard wired for series operation, but the voltage drop through the sensors (see specifications) must not reduce the available voltage below what is needed to actuate the load.

Parker EPS-6 or 7 sensors may also be hard wired for parallel operation. However, the leakage current of each sensor will pass through the load. The total of all leakage currents must not exceed the current required to actuate the load. In most cases, the use of two or more EPS-6 or 7 sensors in parallel will require the use of a bypass (shunt) resistor.

Minimum Stroke

The minimum stroke for EPS-6 or 7 and CLS-1 or 4 sensors, utilizing standard components, is the cushion sleeve or spear length for the cylinder series in which the sensor is installed. See the Cushion Length Chart in this catalog for details. Contact the factory if a shorter stroke is required.



Specifications				
Style:	EPS-7	EPS-6	CLS-1	CLS-4
Code Designator:	H	D	F	B
Description:	Economical, General Purpose, 2 wire device, primarily for AC applications. (Not suitable for 3 wire 24 volt Sinking or Sourcing applications.) Also for automotive industry applications.	Economical, General Purpose, 3 wire, DC sensor, dual output: sinking and sourcing	Functional replacement for AB (Mechanical) Limit Switches in many applications, or where customer needs NC contacts, zero leakage, zero voltage drop, higher or lower load current than EPS-style	Functional replacement for AB (Mechanical) Limit Switches in many High Temperature applications, or where customer needs NC contacts, zero leakage, zero voltage drop, higher or lower load current than EPS-style.
Supply Voltage:	20 to 250 VAC/DC	10 to 30 VDC	24 to 240 VAC/DC	24 to 240 VAC/DC
Load Current, min:	8 mA	N/A	NA	NA
Load Current, max:	300 mA	200 mA	4 AMPS @ 120 VAC 3 AMPS @ 24VDC	4 AMPS @ 120 VAC 3 AMPS @ 24 VDC
Leakage Current:	1.7 mA, max.	10 micro amps max	–	–
Voltage Drop:	7 V, max.	2 VDC max.	N/A	NA
Operating Temperature:	-14° to +158° F	-14° to +158°F	-40°F to +221°F	-40°F to +400°F
Sensor Type:	Inductive proximity	Inductive proximity	non-contacting magnetically actuated	non-contacting magnetically actuated
Part Number:	148897 ¹	148896 ¹	148275 ¹	149109 ¹
Part Number Suffix ¹ :	¹4-digit suffix indicates probe length: 0125=1.25", 0206=2.06", 0287=2.875", 0456=4.562"			
Connection:	3 pin mini	5 pin mini	3 pin mini	144" PTFE Coated Flying Leads with 1/2" conduit hub
Enclosure Rating:	IEC IP67	IEC IP67	NEMA 1, 2, 3, 4, 4x, 5, 6, 6P, 11, 12, 12K, 13	NEMA 1, 2, 3, 4, 4x, 5
LED indication:	Yes	Yes	Yes	No
Short Circuit Protection:	Yes	Yes	No	No
Weld Field Immunity:	Yes	Yes	Yes	Yes
Output:	2 wire, Normally Open with leakage current	Dual Output: DC Sinking and DC Sourcing, user selectable via wiring	SPDT (Single Pole Double Throw), Normally Open/Normally Closed, Form C	SPDT (Single Pole Double Throw), Normally Open/Normally Closed, Form C
Approvals/Marks:	CE, UL, CSA	CE, UL, CSA	UL or CSA ²	UL or CSA ²
Make/Break Location:	0.13" from end of stroke, typical. Tolerance is +0/-0.13"			
Wiring Instructions:	Pin 1: AC Ground (Green) Pin 2: Output (Black) Pin 3: AC Line (White)	Pin 1) +10 to 30 VDC (White) Pin 2) Sourcing Output (Red) Pin 3) Grounded (not connected or required) Pin 4) Sinking Output (Orange) Pin 5) DC Common (Black)	Pin 1: Common (Green) Pin 2: Normally Closed (Black) Pin 3: Normally Open (White)	Common: (Black) Normally Open: (Blue) Normally Closed: (Red)
Cable: 6'	0853550006	0859170006	0853550006	–
Cable: 12'	0853550012	0859170012	0853550012	–
Cable: 6', Right Angle	0875470006	–	0875470006	–

²CSA available upon request – contact factory.

How to Specify EPS Proximity Switches

Parker EPS proximity switches may be ordered on Series 2H & 3H cylinders as follows:

- 1) Complete the basic cylinder model number.
- 2) Place an "S" in the model number to denote switches and/or special features.
- 3) Mounting styles D, DB, JJ, J, or H should be used with caution because of possible mounting interferences. Consult bulletin 0840-G-E1 for additional information.
- 4) Special modifications to cylinders other than switches must have a written description.

5) Specify letter prefix "H" for EPS-7, "D" for EPS-6, and "F" for CLS-1, or "B" for CLS-4, then fill in the four blanks specifying port location, switch orientation and actuation point for both head and cap. If only one switch is used, place "XXXX" in the unused blanks.

Example = H13AGG-XXXX denotes a switch on the head end only, EPS-7

Example = XXXX-H42AGG denotes a switch on the cap end only, CLS-4

Head End

H	1	3	A	GG
Specify: "H" = EPS-7 "D" = EPS-6 "F" = CLS-1 ¹ "B" = CLS-4 ¹ "N" = Prep for EPS-6 and EPS-7 switches "P" = Prep for CLS-1 and CLS-4 switches "T" = Prep for CLS-2 switch	Port Location See Figure 1.	Switch Location See Figure 1.	Switch Orientation See Figure 2 for EPS-7, EPS-6, CLS-1 and CLS-4.	Actuation Point GG = End of Stroke FF = Stroke to Go; See Bulletins 0840-G-E1, 2 or 3 for stroke remaining.

Cap End

H	4	2	A	GG
Specify: "H" = EPS-7 "D" = EPS-6 "F" = CLS-1 ¹ "B" = CLS-4 ¹ "N" = Prep for EPS-6 and EPS-7 switches "P" = Prep for CLS-1 and CLS-4 switches "T" = Prep for CLS-2 switch	Port Location See Figure 1.	Switch Location See Figure 1.	Switch Orientation See Figure 2 for EPS-7, EPS-6, CLS-1 and CLS-4.	Actuation Point GG = End of Stroke FF = Stroke to Go; See Bulletins 0840-G-E1, 2 or 3 for stroke remaining.

Note: All specified switch and port locations are as seen from rod end of cylinder.

¹ CLS-1 and CLS-4 proximity switches are not available on the head end of 1.50" bore with 1.00" rod and 2.00" bore with 1.375" rod

Figure 1

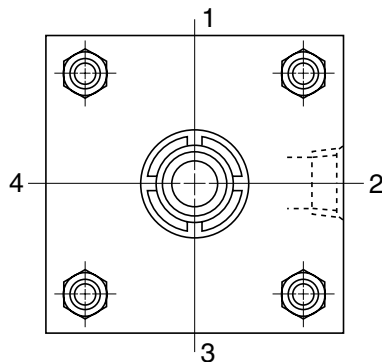
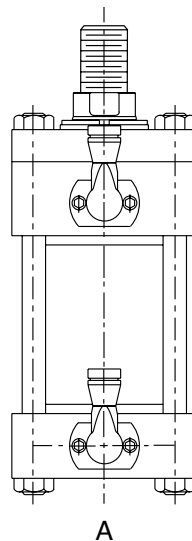

Figure 2



Notes

Section E

Series 2H / 3H Engineering Data

Theoretical Push and Pull Forces	98, 99
Cylinder Weights	100
Operating Fluids and Seals / Temperature Range	101
Fluids and Temperature Range / Pressure Ratings	102
Ports	103, 104
Stroke Data / Mounting Groups	105
Stop Tubing	106
Piston Rod Selection Data	107-109
Cushioning	110-115
Manufacturing Locations	117
Cylinder Safety Guide	118, 119
Offer of Sale	120



Theoretical Push Forces for Hydraulic Cylinders

Cylinder Bore Ø	Piston Area (Sq. In.)	Cylinder Push Stroke Force in Pounds at Various Pressures						
		100	250	500	1000	1500	2000	3000
1.50	1.77	177	443	885	1770	2651	3540	5310
2.00	3.14	314	785	1570	3140	4712	6280	9420
2.50	4.91	491	1228	2455	4910	7363	9820	14730
3.25	8.30	830	2075	4150	8300	12444	16600	24900
4.00	12.57	1257	3143	6285	12570	18850	25140	37710
5.00	19.64	1964	4910	9820	19640	29453	39280	58920
6.00	28.27	2827	7068	14135	28270	42412	56540	84810
7.00	38.49	3849	9623	19245	38490	57727	76980	115470
8.00	50.27	5027	12568	25135	50270	75398	100540	150810
10.00	78.54	7854	19635	39270	78540	117810	157080	235620
12.00	113.10	11310	28275	56550	113100	169650	226200	339300
14.00	153.94	15394	38485	76970	153940	230910	307880	461820
16.00	201.06	20106	50265	100530	201060	301590	402120	603180
18.00	254.47	25447	63620	127230	254470	381700	508940	763410
20.00	314.16	31416	78540	157080	314160	471240	628320	942480

General Formula

The cylinder output forces are derived from the formula:

$$F = P \times A$$

Where F = Force in pounds.

P = Pressure at the cylinder in pounds per square inch, gauge.

A = Effective area of cylinder piston in square inches.

Theoretical Pull Forces for Hydraulic Cylinders

Cylinder Bore Ø	Piston Rod Ø	Piston Rod Area (Sq. In.)	Cylinder Pull Force in Pounds at Various Pressures (psi)						
			100	250	500	1000	1500	2000	3000
1.50	0.625	0.307	146	365	730	1460	2190	2920	4380
	1.000	0.785	98	245	491	982	1473	1964	2946
2.00	1.000	0.785	236	589	1178	2355	3533	4710	7065
	1.375	1.48	166	414	828	1655	2483	3310	4965
2.50	1.000	0.785	413	1031	2063	4125	6188	8250	12375
	1.375	1.48	343	856	1713	3425	5138	6850	10275
	1.750	2.41	250	625	1250	2500	3750	5000	7500
3.25	1.375	1.48	682	1704	3408	6815	10223	13630	20445
	1.750	2.41	589	1473	2945	5890	8835	11780	17670
	2.000	3.14	516	1290	2580	5160	7740	10320	15480
4.00	1.750	2.41	1016	2540	5080	10160	15240	20320	30480
	2.000	3.14	943	2358	4715	9430	14145	18860	28290
	2.500	4.91	766	1915	3830	7660	11490	15320	22980
5.00	2.000	3.14	1650	4125	8250	16500	24750	33000	49500
	2.500	4.91	1473	3683	7365	14730	22095	29460	44190
	3.000	7.07	1257	3143	6285	12570	18855	25140	37710
	3.500	9.62	1002	2505	5010	10020	15030	20040	30060
6.00	2.500	4.91	2336	5840	11680	23360	35040	46720	70080
	3.000	7.07	2120	5300	10600	21200	31800	42400	63600
	3.500	9.62	1865	4663	9325	18650	27975	37300	55950
	4.000	12.57	1570	3925	7850	15700	23550	31400	47100
7.00	3.000	7.07	3142	7855	15710	31420	47130	62840	94260
	3.500	9.62	2887	7218	14435	28870	43305	57740	86610
	4.000	12.57	2592	6480	12960	25920	38880	51840	77760
	4.500	15.90	2259	5648	11295	22590	33885	45180	67770
	5.000	19.63	1886	4715	9430	18860	28290	37720	56580
8.00	3.500	9.62	4065	10163	20325	40650	60975	81300	121950
	4.000	12.57	3770	9425	18850	37700	56550	75400	113100
	4.500	15.90	3437	8593	17185	34370	51555	68740	103110
	5.000	19.63	3064	7660	15320	30640	45960	61280	91920
	5.500	23.76	2651	6628	13255	26510	39765	53020	79530
10.00	4.500	15.90	6264	15660	31320	62640	93960	125280	187920
	5.000	19.63	5891	14728	29455	58910	88365	117820	176730
	5.500	23.76	5478	13695	27390	54780	82170	109560	164340
	7.000	38.48	4006	10015	20030	40060	60090	80120	120180
12.00	5.500	23.76	8934	22335	44670	89340	134010	178680	268020
	7.000	38.48	7462	18655	37310	74620	111930	149240	223860
	8.000	50.26	6284	15710	31420	62840	94260	125680	188520
14.00	7.000	38.48	11546	28865	57730	115460	173190	230920	346380
	8.000	50.26	10368	25920	51840	103680	155520	207360	311040
	10.000	78.54	7540	18850	37700	75400	113100	150800	226200
16.00	8.000	50.26	15080	37700	75400	150800	226200	301600	452400
	9.000	63.62	13744	34360	68720	137440	206160	274880	412320
	10.000	78.54	12252	30630	61260	122520	183780	245040	367560
18.00	9.000	63.62	19085	47713	95425	190850	286275	381700	572550
	10.000	78.54	17593	43983	87965	175930	263895	351860	527790
20.00	10.000	78.54	23562	58905	117810	235620	353430	471240	706860



Cylinder Weights

**Heavy Duty Hydraulic Cylinders
Series 2H / 3H Engineering Data**

The weights shown below are for standard Series 2H and 3H hydraulic cylinders equipped with various diameter piston rods. To determine the net weights of a cylinder, first select the proper basic weight for zero stroke, then calculate the weight of the cylinder stroke and add the result to the basic weight. For extra rod

extension use piston rod weights per inch shown in Table C. Weights of cylinders with intermediate rods may be estimated from table below by taking the difference between the piston rod weights per inch and adding it to the Code 1 weight for the cylinder bore size involved.

Table A Cylinder Weights, in pounds, for Series 2H, 3H (7.00" & 8.00") hydraulic cylinders

Bore Ø	Rod Ø	Rod Code	Single Rod Cylinders Basic Wt. Zero Stroke		Add Per Inch of Stroke	Double Rod Cylinders Basic Wt. Zero Stroke		Add Per Inch of Stroke
			F, H, HB, J, JB T, TB, TC, TD	BB, C, CB, D, DB DD, DE, G, HH, JJ		KF, KJ, KJB KT, KTB, KTD	DE, KC, KCB, KD KDD, KE, KJJ	
1.50	0.625	1	7.8	9.0	0.5	9.7	10.8	0.6
	1.000	2	8.4	9.3	0.6	9.1	10.7	0.8
2.00	1.000	1	11.6	13.2	0.8	14.6	16.8	1.0
	1.375	2	13.5	17.1	1.0	19.4	20.6	1.4
2.50	1.000	1	17.0	19.5	1.1	21.0	24.5	1.3
	1.750	2	22.5	25.5	1.5	27.0	30.0	2.2
3.25	1.375	1	32.0	41.0	1.8	43.0	52.0	2.2
	2.000	2	37.0	46.0	2.2	48.0	57.0	3.1
4.00	1.750	1	48.0	53.0	2.5	59.0	63.0	3.2
	2.500	2	52.0	58.0	3.2	92.0	97.0	4.6
5.00	2.000	1	76.0	82.0	3.4	96.0	102.0	4.8
	3.500	2	88.0	86.0	5.2	117.0	123.0	7.9
6.00	2.500	1	125.0	133.0	5.2	153.0	159.0	6.6
	4.000	2	133.0	140.0	7.3	182.0	190.0	10.9
7.00	3.000	1	233.0	242.0	6.7	320.0	339.0	8.7
	5.000	2	240.0	253.0	10.3	341.0	360.0	15.9
8.00	3.500	1	262.0	276.0	9.0	323.0	331.0	11.7
	5.500	2	300.0	309.0	13.0	390.0	411.0	19.7

Table B Cylinder Weights, in pounds, for Series 3H large bore hydraulic cylinders

Bore Ø	Rod Ø	Rod Code	Single Rod Cylinders Basic Wt. Zero Stroke				Add Per Inch of Stroke	Double Rod Cylinders	
			D, DB	DD, JJ, HH	JB, HB	BB, C		Basic Wt. Zero Stroke Add to All Mtg. Styles	Add Per Inch of Stroke
10.00	4.500	1	562	646	684	607	15	43	20
	5.000	3	574	656	695	619	16	50	21
	5.500	4	583	667	705	628	17	64	24
	7.000	2	620	704	742	665	21	101	32
12.00	5.500	1	924	1057	1136	1000	22	64	29
	7.000	3	961	1094	1173	1036	26	101	37
	8.000	2	1022	1155	1234	1097	29	162	43
14.00	7.000	1	1335	1520	1582	1485	28	101	39
	8.000	3	1396	1581	1643	1546	31	162	45
	10.000	2	1496	1681	1743	1646	39	262	61

Bore Ø	Rod Ø	Rod Code	Single Rod Cylinders Basic Wt. Zero Stroke			Add Per Inch of Stroke	Double Rod Cylinders	
			JJ, HH	JB, HB	BB		Basic Wt. Zero Stroke Add to All Mtg. Styles	Add Per Inch of Stroke
16.00	8.000	1	2073	2257	2226	35	149	49
	9.000	3	2122	2305	2275	39	198	57
	10.000	4	2181	2364	2334	43	257	65
18.00	9.000	1	3165	3256	3330	45	198	63
	10.000	3	3224	3315	3390	50	257	72
20.00	10.000	1	4231	4406	4551	57	257	79

Table C Extra weight for longer than standard rod extensions can be calculated from table below.

Rod Ø	Piston Rod Wt. Per Inch	Rod Ø	Piston Rod Wt. Per Inch	Rod Ø	Piston Rod Wt. Per Inch
0.625	0.09	2.500	1.40	5.000	5.56
1.000	0.22	3.000	2.00	5.500	6.72
1.375	0.42	3.500	2.72	7.000	10.89
1.750	0.68	4.000	3.56	8.000	14.22
2.000	0.89	4.500	4.51	10.000	22.23



Operating Fluids and Temperature Range

Fluidpower cylinders are designed for use with pressurized air, hydraulic oil and fire resistant fluids, in some cases special seals are required.

Standard Seals (class 1)

Class 1 seals are what is normally provided in a cylinder unless otherwise specified. They are intended for use with fluids such as: air, nitrogen, mineral base hydraulic oil or MIL-H-5606 within the temperature range of -10°F (-23°C) to +165°F (+74°C). Generally they are nitrile except for piston rod seals in hydraulic cylinders. However the individual seals may be nitrile (Buna-N) enhanced polyurethane, polymyte, PTFE or filled PTFE

Water Base Fluid Seals (class 2)

Generally class 2 seals are intended for use with water base fluids within the temperature of -10°F (-23°C) to +165°F (+74°C) except for High Water Content Fluids (HWCF) in which case Class 6 seals should be used. Typical water base fluids are: Water, Water-Glycol, Water-in Emulsion, Houghto-Safe 27, 620, 5040, Mobil Pyrogard D, Shell Iruis 905, Ucon Hydrolube J-4. These seals are nitrile. Lipseal will have polymyte or PTFE back-up washer when required. O-rings will have nitrile back-up washers when required.

Ethylene Propylene (EPR) Seals (class 3)

Class 3 seals are intended for use with some Phosphate Ester Fluids between the temperatures of -10°F (-23°C) to +130°F (+54°C). Typical fluids compatible with EPR seals are Skydrol 500 and 700. EPR are Ethylene Propylene. Lipseals will have a PTFE back-up washer when required. O-rings will have EPR back-up washers when required.

Note: EPR seals are not compatible with mineral base hydraulic oil or greases. Even limited exposure to these fluids will cause severe swelling. PTFE back-up washer may not be suitable when used in a radiation environment.

Low Temperature Nitrile Seals (class 4)

Class 4 seals are intended for low temperature service with the same type of fluids as used with Class 1 seals within the temperature range of -50°F (-46°C) to +150°F (+66°C). Lipseals will have leather, polymyte or PTFE back-up washers when required. O-rings will have nitrile back-up washers when required. **Note:** Certain fluids may react adversely with Class 4 seals compared to Class 1 seals.

Fluorocarbon Seals (class 5)

Class 5 seals are intended for elevated temperature service or for some Phosphate Ester Fluids such as Houghto-Safe 1010, 1055, 1120; Fyrquel 150, 220, 300, 350; Mobile Pyrogard 42, 43, 53, and 55. **Note:** In addition, class 5 seals can be used with fluids listed below under standard service. However, they are not compatible with Phosphate Ester Fluids such as Skydrols. Class 5 seals can operate with a temperature range of -10°F (-23°C) to +250°F (+121°C). Class 5 seals may be operated to +400°F (+204°C) with limited service life. For temperatures above +250°F (+121°C) the cylinder must be manufactured with non-studded piston rod and thread and a pinned piston to rod connection. Class 5 Lipseals will have PTFE back-up washers when required. O-rings will have fluorocarbon back-up when required.

HWCF Seals (class 6)

Class 6 seals are intended for High Water Content Fluids (HWCF) such as Houghton, Hydrolubric 120B and Sonsol Lubrizol within the temperature range of +40°F (+4°C) to +120°F (+49°C). Class 6 seals are special nitrile compound dynamic seals. Lipseals will have PTFE and/or polymyte back-up washers when required. O-rings will have nitrile back-up washers when required. Because of the viscosity of these fluids, cylinders specified with class 6 seals, will also be modified to have lip seal piston seals and straight cushions.

Energized PTFE Seals (class 8)

Class 8 seals consist of PTFE piston lipseals, rod seal and wiperseal. Piston seals have an internal stainless steel spring to energize both the static and dynamic sealing lips. They are intended for high temperature applications, to 400° F (204° C), where longer seal life and improved high temperature sealing performance is required. Minimum operating temperature is -15°F (-26°C). Body and gland o-ring seals will be fluorocarbon. Fluid resistance is comparable to Class 5. Cylinders incorporating Class 8 Seals will not have studded piston rods.

Warning ⚠

The piston rod stud and the piston rod to piston threaded connections are secured with an anaerobic adhesive which is temperature sensitive. Cylinders are assembled with anaerobic adhesive having a maximum temperature rating of +250°F (+121°C). Cylinders specified with all other seal compounds (built before 1997) were assembled with anaerobic adhesive having a maximum operating temperature rating +165°F (+74°C). These temperature limitations are necessary to prevent the possible loosening of the threaded connections. Cylinders

originally manufactured (before 1997) with class 1 seals (Nitrile) that will be exposed to ambient temperatures above +165°F (+74°C) must be modified for higher temperature service. Contact the factory immediately and arrange for the piston to rod and the stud to piston rod connections to be properly re-assembled to withstand the higher temperature service.

Hi-Load Seals

Hi-load seals consist of one or two filled PTFE dynamic piston seals with an elastomer expander underneath. Hi-load piston arrangement normally consists of a wear ring on each end of the piston with the seals in the middle. These types of seals are virtually leak free seals under static conditions and can tolerate high pressure. The wear rings on the piston can also tolerate high side loads. The dynamic portion of the seal is bronze filled PTFE and compatible with all conditions and fluids listed on this page. However, carbon filled PTFE will provide better seal life when used with class 6 fluids. A nitrile expander will be provided unless Class 3 or 5 seals are specified. In those cases the expander will be of EPR or fluorocarbon respectively. **Note:** It may be necessary to cycle the piston seals 40 or 50 times before achieving leakage free performance.

Lipseal Pistons

Under most conditions lipseals provide the best all around service for pneumatic applications. Lipseals with a back-up washer are often used for hydraulic applications when virtually zero static leakage is required. Lipseals will function properly in these applications when used in conjunction with moderate hydraulic pressures. A high load piston option is recommended when operating at high pressures and especially with large bore hydraulic cylinders.

Low Friction Hydraulic Seals

Low Friction hydraulic seals are available as an option for both piston and rod seals for Series 2H and 3H cylinders. They are sometimes used when a cylinder is controlled by servo or proportional valve. The seal assembly itself is a two piece assembly consisting of a filled PTFE dynamic seal with an elastomer expander. A piston seal assembly consists of one seal assembly in the middle of the piston with a filled PTFE wear ring on each side of the piston. The piston rod seal assembly consists of two seal assemblies and an elastomer wiper seal. The filled PTFE seals are compatible with the fluids listed on this page and provide virtually leak free sealing. The expanders and rod wiper will be fluorocarbon unless EPR or fluorocarbon seals are specified. In those cases the expanders and wiper will be EPR and fluorocarbon respectively. When specifying low friction seals specify if piston, piston rod seals or both are required. **Note:** It may be necessary to cycle these seals 40 or 50 times before achieving leakage free performance.

Cast Iron Piston Rings

Cast iron rings are the standard piston seals for Series 2H cylinders. They offer the widest operating conditions by tolerating high operating pressures, wide temperature range and are compatible with most fluids. The only drawback of cast iron rings is that they allow a small amount of leakage. The leakage for a 4" bore cylinder, operating at 2000 psi, with mineral base hydraulic fluid will be less than 10in³/min. Leakage will increase as pressure and bore size increase, and viscosity of the operating hydraulic fluid decreases. For these reasons cast iron rings are not recommended when using water or (HWCF) fluids.

Water Service

Series 2H cylinders can be modified to make them more suitable for use with water as the operating medium. The modifications include chrome-plated cylinder bore; electroless nickel-plated head, cap and piston; chrome-plated 17-4 stainless steel piston rod; chrome plated cushion sleeve or cushion spear.

Modified cylinders may also be used for higher operating pressures, up to 2000 psi, depending on bore size. See pressure rating for Hydraulic Cylinders on the next page. Series 2H and 3H hydraulic cylinders can also be modified for water operation and supplied with chrome-plated cylinder bore; electroless nickel-plated head, cap and piston; chrome-plated precipitation hardened stainless steel piston rod, chrome-plated cushion sleeve or cushion spear. When high water base fluids are the operating medium, hydraulic cylinders are usually supplied with high water base rod wiper and seals. Water and high water base fluid operated cylinders are best used on short stroke applications or where high pressure is applied only to clamp the load.

Warranty

Parker Hannifin will warrant cylinders modified for water or high water content fluid service to be free of defects in materials or workmanship, but cannot accept responsibility to premature failure due to excessive wear due to lack of lubricity or where failure is caused by corrosion, electrolysis or mineral deposits within the cylinder.

Fluids and Temperature Range

Class No.	Typical Fluids	Temperature Range
1 (Standard) (Nitrile Polyurethane)	Air, Nitrogen Hydraulic Oil, Mil-H-5606 Oil	-10°F (-23°C) to +165°F (+74°C)
2 Optional Water Base Fluid Seal	Water, Water-Glycol, HWCF — See Class 6 below. Water-in-Oil Emulsion Houghto-Safe, 271, 620, 5040. Mobil Pyrogard D, Shell IruS 905. Ucon Hydrolube J-4	-10°F (-23°C) to +165°F (+74°C)
3 Special (EPR) (at extra cost) Note: (EPR) seals are not compatible with Hydraulic Oil	Some Phosphate Ester Fluids Skydrol 500, 7000	-10°F (-23°C) to +130°F (+54°C)
4 Special (Nitrile) (at extra cost)	Low Temperature Air or Hydraulic Oil	-50°F (-46°C) to +150°F (+66°C)
5 Optional (at extra cost) (Fluorocarbon Seals) Note: Fluorocarbon seals are not suitable for use with Skydrol fluid, but can be used with hydraulic oil if desired.	High Temperature Houghto-Safe 1010, 1055, 1120 Fyrquel 150, 220, 300, 550 Mobil Pyrogard 42,43,53,55	See paragraph on Fluorocarbon seals for recommended temperature range.
6 Optional (HWCF) (at extra cost)	Houghton, Hydrolubric 120B Sonsol Lubrizol, for other HWCF — consult factory.	+40°F (+4°C) to +120°F (+49°C)
8 Optional (at extra cost) Energized PTFE	See Class 5 Seals	-15°F (-26°C) to +400°F (+204°C)

Application Data

The proper application of a fluid power cylinder requires consideration of the operating pressure, the fluid medium, the mounting style, the length of stroke, the type of piston rod connection to the load, thrust or

tension loading on the rod, mounting attitude, the speed of stroke, and how the load in motion will be stopped. Information given here provides pressure rating data for pneumatic and hydraulic cylinders.

Pressure Ratings

Standard operating fluid — clean, filtered hydraulic oil. Pressure ratings for heavy-duty hydraulic cylinders are shown in the table.

Series 2H and 3H hydraulic cylinders are recommended for pressures to 3000 psi for heavy-duty service with hydraulic oil. The 4:1 design factor ratings shown are based on tensile strength of material and are for standard rod diameter only. The rating is conservative for continuous severe applications. Design factors at other pressures can be calculated from this rating. In addition, mounting styles, stroke, etc., should be considered because of the limiting effect they may have on these ratings.

**Series 2H & 3H Hydraulic Cylinders
Maximum Pressure Ratings**

Bore Ø	Rod Ø	4:1 ¹ Design Factor (Tensile) (psi)	Heavy-Duty Service (psi)
1.50	0.625	2530	3000
2.00	1.000	2950	3000
2.50	1.000	2340	3000
3.25	1.375	2250	3000
4.00	1.750	2130	3000
5.00	2.000	2170	3000
6.00	2.500	2270	3000
7.00	3.000	2030	3000
8.00	3.500	2040	3000
10.00	4.500	2720	3000
12.00	5.500	2580	3000
14.00	7.000	2320	3000
16.00	8.000	2750	3000
18.00	9.000	2900	3000
20.00	10.000	2640	3000

¹ Applies to all mountings except Styles J, JB, H, D, DB, DD.



Ports

Ports

Series 2H and 3H cylinders can be supplied with SAE straight O-ring ports or NPTF pipe thread ports. If specified on your order, extra ports can be provided on the sides of heads or caps that are not occupied by mountings or cushion valve.

Standard port location is position 1 as shown on line drawings in product catalog and Figure 1 below. Cushion adjustment needle and check valves are at positions 2 and 4 (or 3), depending on mounting style. Heads or caps which do not have an integral mounting can be rotated and assembled with ports at 90° or 180° from standard position. Mounting styles on which head or cap can be rotated at no extra charge are shown in Table A below. To order, specify by position number. In such assemblies the cushion adjustment needle and check valve rotate accordingly since their relationship with port position does not change.

Figure 1

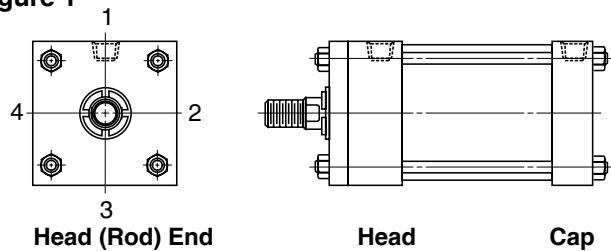

Table A

Mounting Style	Port Position Available	
	Head End	Cap End
TB, TC, TD, J, H, JB, HB, DD, DE	1, 2, 3 or 4	1, 2, 3 or 4
HH, DB, BB, SB	1, 2, 3 or 4	1 or 3
JJ, D	1 or 3	1, 2, 3 or 4
C, F	1	1

Ports can be supplied at positions other than those shown in Table A at an extra charge. To order, specify port position as shown in Figure 1.

Straight Thread Ports

The SAE straight thread O-ring port is recommended for hydraulic applications. Parker will furnish this port configuration at positions shown in Table A. This port can also be provided at positions other than those shown in Table A at an extra charge. SAE port size numbers are listed next to the NPTF pipe thread counterparts for each bore size in the respective product catalogs. Size number, tube O.D., and port thread size for SAE ports are listed in Table B.

Table B

SAE Straight Thread O-Ring Ports

Size No.	Tube O.D. (In.)	Thread Size	Size No.	Tube O.D. (In.)	Thread Size
2	0.13	5/16 - 24	12	0.75	1 1/16 - 12
3	0.19	3/8 - 24	—	—	—
4	0.25	7/16 - 20	16	1.00	1 5/16 - 12
5	0.31	1/2 - 20	20	1.25	1 5/8 - 12
6	0.38	9/16 - 18	24	1.50	1 7/8 - 12
8	0.50	3/4 - 16	32	2.00	2 1/2 - 12
10	0.63	7/8 - 14	—	—	—

Note: For the pressure ratings of individual connectors, contact your connector supplier. Hydraulic cylinders applied with meter out or deceleration circuits are subject to intensified pressure at the cylinder piston rod end. The rod end pressure is approximately equal to:

$$\frac{\text{Effective Cap End Piston Area}}{\text{Effective Rod End Piston Area}} \times \text{Operating Pressure}$$

International Ports

Other port configurations to meet international requirements are available at extra cost. Parker Series 2H and 3H cylinders can be supplied, on request, with British standard taper port (BSPT). Such port has a taper of 1 in 16 measured on the diameter (1/16" per inch). The thread form is Whitworth System, and size and number of threads per inch are as follows:

Table C

British Standard Pipe Threads

Nominal Pipe Size	No. Threads Per Inch	Pipe O.D.
1/8	28	0.383
1/4	19	0.518
3/8	19	0.656
1/2	14	0.825
3/4	14	1.041
1	11	1.309
1 1/4	11	1.650
1 1/2	11	1.882
2	11	2.347

British standard parallel internal threads are designated as BSPP and have the same thread form and number of threads per inch as the BSPT type and can be supplied, on request, at extra cost. Unless otherwise specified, the BSPP or BSPT port size supplied will be the same nominal pipe size as the NPTF port for a given bore size cylinder.

Metric ports can also be supplied to order at extra cost. See table below for standard port size for each bore.

Table D – Standard Port Sizes

Bore Ø	T SAE	U NPTF	P SAE Code 61 Flange	Y ISO 6149	B BSPT R BSPP	G Metric
1.50	10	1/2	N/A	M22 x 1.5	1/2	M22 x 1.5
2.00	10	1/2	N/A	M22 x 1.5	1/2	M22 x 1.5
2.50	10	1/2	1/2'	M22 x 1.5	1/2	M22 x 1.5
3.25	12	3/4	3/4	M27 x 2	3/4	M27 x 2
4.00	12	3/4	3/4	M27 x 2	3/4	M27 x 2
5.00	12	3/4	3/4	M27 x 2	3/4	M27 x 2
6.00	16	1	1	M33 x 2	1	M33 x 2

Bore Ø	T SAE	U NPTF	P SAE Code 61 Flange	Y ISO 6149	B BSPT R BSPP	G Metric
7.00	20	1 1/4	1 1/4	M42 x 2	1 1/4	M42 x 2
8.00	24	1 1/2	1 1/2	M48 x 2	1 1/2	M48 x 2
10.00	24	2	2	M48 x 2	2	M48 x 2
12.00	24	2 1/2	2 1/2	M48 x 2	2 1/2	M48 x 2
14.00	24	2 1/2	2 1/2	M48 x 2	2 1/2	M48 x 2
16.00-20.00	24	—	3	—	—	—

¹Available with 1.000 inch rod diameter only.



Oversize Ports

Oversize NPTF or SAE straight thread ports can be provided, at an extra charge. For ports one size larger than standard, welded port bosses which protrude from the side of the head or cap are supplied. For dimensions, see drawings and tables below. Series 2H and 3H cylinders equipped with cushions at the cylinder cap end can sustain damage to the cushion check valve (cushion bushing) if excessive oil flow enters the cylinder from the cap end port. Cylinders which are equipped with cap end cushions and ordered with one size oversize ports having hydraulic fluid flow exceeding 25 ft./sec. in the

line entering the cap end of the cylinder should be ordered with a "solid cushion" at cap end. All cylinders ordered with double oversize ports should always be ordered with a "solid cushion" at cap end.

Cylinders which are connected to a meter out flow control with flow entering the cap end of a cylinder provided by an accumulator may also experience damage to the cushion bushing due to high instantaneous fluid flows. This condition can be eliminated by using a meter in flow control or "solid cushions" at cap end.

Oversize NPTF Port Boss Dimensions

Bore Ø	EE (NPTF)	A Ø	B	C	D	P
1.50	3/4	1.38	1.00	0.75	0.78	2.91
2.00	3/4	1.38	1.00	0.75	0.78	2.91
2.50	3/4	1.38	1.00	0.75	0.78	3.03
3.25	1	1.75	1.19	0.91	0.88	3.53
4.00	1	1.75	1.19	0.91	0.88	3.78
5.00	1	1.75	1.19	0.91	0.88	4.28
6.00	1 1/4	2.25	1.31	1.13	1.13	5.13
7.00	1 1/2	2.50	1.56	1.38	1.38	5.75
8.00	2	3.00	1.69	1.50	1.50	6.50

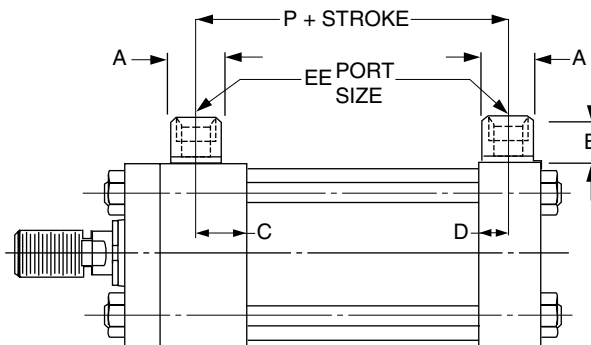

Oversize SAE Straight Thread Port Boss Dimensions

Bore Ø	EE (SAE)		A Ø	B	C	D	P
	2H	2HD					
1.50	12 ¹	12	1.38	1.00	0.81	0.78	2.97
2.00	12 ¹	12	1.38	1.00	0.81	0.78	2.97
2.50	12 ²	12 ³	1.38	1.00	0.81	0.81	3.13
3.25	16	16	1.75	1.19	0.91	0.91	3.56
4.00	16	16	1.75	1.19	0.91	0.91	3.81
5.00	16	16	1.75	1.19	0.91	0.91	4.31
6.00	20 ²	20 ²	-	-	1.13	1.17	5.19
7.00	24 ²	24 ²	-	-	-	-	5.63
8.00	N/A	N/A	-	-	-	-	6.38

¹ Port tapped directly in head with code 1 rod these bores.
² Port tapped directly in head (all rod codes) and cap these bores.
³ Port tapped directly in cap this bore.

Flange Ports (Code 61, 3000 psi) SAE 4 Bolt Flange Ports

Bore Ø	Rod No.	SAE Dash No.	A Ø	AA	GG	P	Q	W	X	Y	Z
2.50 ^{4,5}	1	8	.50	.81	.69	2.97	1.50	.75	.34	2.38	5/16 - 18
	1									2.75	
3.25 ⁴	2	12	.75	.75	.87	3.47	1.87	.94	.44	3.13	3/8 - 16
	3									3.00	
4.00 ⁴	1									3.00	
	2	12	.75	.75	.87	3.72	1.87	.94	.44	3.38	3/8 - 16
	3									3.13	
5.00 ⁴	1									3.13	
	2	12	.75	.75	.87	4.22	1.87	.94	.44	3.38	3/8 - 16
	3									3.38	
	4									3.38	
6.00	All	16	1.00	.87	1.03	4.85	2.06	1.03	.52	3.50	3/8 - 16
7.00	All	20	1.25	1.00	1.19	5.47	2.31	1.16	.59	3.75	7/16 - 14
8.00	All	24	1.50	1.06	1.41	6.19	2.75	1.37	.70	3.88	1/2 - 13

⁴ 2.50", 3.25", 4.00" & 5.00" bores cap-flange port not available on Style HB
 Style H not available at position 2 or 4. Port flange overhangs cap on Style HH.
⁵ 2.50" bore head flange port available with 1.000" rod only.

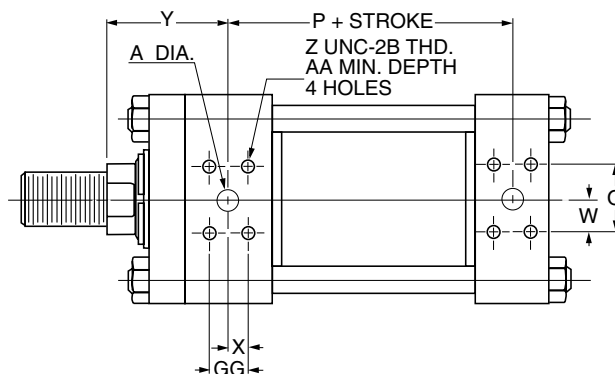

Stroke Data

Parker cylinders are available in any practical stroke length. The following information should prove helpful to you in selecting the proper stroke for your cylinder application.

Stroke Tolerances

Stroke length tolerances are required due to buildup of tolerances of piston, head, cap and cylinder tube. Standard production of stroke tolerances run $+0.031"$ to

$-0.015"$ up to 20" stroke, $+0.031"$ to $-0.020"$ for 21" to 60" and $+0.031"$ to $-0.031"$ for greater than 60" stroke. For closer tolerances on stroke length, it is necessary to specify the required tolerance plus the pressure and temperature at which the cylinder will operate. Stroke tolerances smaller than $.015"$ are not generally practical due to elasticity of cylinders. If machine design requires such close tolerances, use of a stroke adjuster may achieve the desired result.

Mounting Groups

Standard mountings for fluid power cylinders fall into three basic groups. The groups can be summarized as follows:

Group 1 Straight Line Force Transfer with fixed mounts which absorb force on cylinder centerline.

Group 2 Pivot Force Transfer. Pivot mountings permit a cylinder to change its alignment in one plane.

Group 3 Straight Line Force Transfer with fixed mounts which do not absorb force on cylinder centerline.

Because a cylinder's mounting directly affects the maximum pressure at which the cylinder can be used, the chart below should be helpful in selection of the proper mounting combination for your application. Stroke length, piston rod connection to load, extra piston rod length over standard, etc., should be considered for thrust loads. Alloy steel mounting bolts are recommended for all mounting styles, and thrust keys are recommended for Styles C and F.

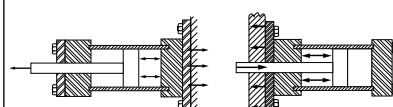
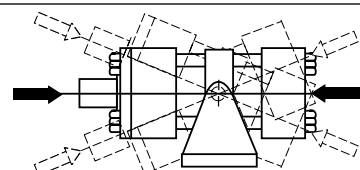
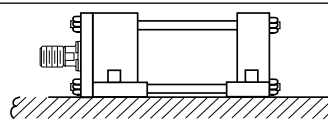
Group 1 FIXED MOUNTS which absorb force on cylinder centerline.	
<p>Heavy-Duty Service For Thrust Loads For Tension Loads</p>	 <p>Styles HB, HH, TC Styles JB, JJ, TB</p>
<p>Medium-Duty Service For Thrust Loads For Tension Loads</p>	<p>Styles H, HB Styles J, JB</p>
<p>Light-Duty Service For Thrust Loads For Tension Loads</p>	<p>Style H Style J</p>
Group 2 PIVOT MOUNTS which absorb force on cylinder centerline.	
<p>Heavy-Duty Service For Thrust Loads For Tension Loads</p>	 <p>Styles DD, D, DE Styles BB, DD, D, DB, DE</p>
<p>Medium-Duty Service For Thrust Loads For Tension Loads</p>	<p>Styles BB, SB Styles BB, SB</p>
Group 3 FIXED MOUNTS which do not absorb force on the centerline.	
<p>Heavy-Duty Service For Thrust Loads For Tension Loads</p>	 <p>Styles C, CP Styles C, CP</p>
<p>Medium-Duty Service For Thrust Loads For Tension Loads</p>	<p>Styles F, FP Styles F, FP</p>



Stop Tubing

Stop tube is recommended to lengthen the distance between the rod bearing and piston bearing to reduce bearing loads on long push stroke cylinders when the cylinder is fully extended. This is especially true of horizontally mounted cylinders. As part of the piston assembly and positioned between the piston and head, a stop tube restricts the extended position of the rod using the increased distance to achieve additional stability.

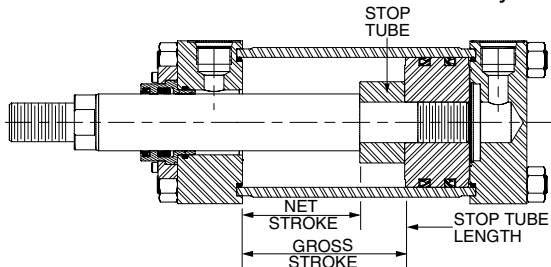

Use the following steps to determine the need for stop tube and, if required, how long it should be.

1. Examine the groups of cylinder illustrations below and determine which mounting and rod guiding group type match the required cylinder application.

2. Establish the Basic Length (L), with the piston rod fully extended, for the selected illustration by using the dimensional tables on previous pages of this catalog. For pivot mounted cylinders, the pin-to-pin dimension with the piston rod fully extended must be used. Regardless of mounting style, be sure to include any extended piston rod length beyond the catalog standard.

3. In the Stop Tube Table select the column for the appropriate mounting style and rod end guiding type. In the Basic Length (L) column, find the row with the range that includes the value calculated in Step 2. The next respective column to the right has the required length of stop tube.

Note: Mounting Styles BB, DB, H, HB, HH and SB that are mounted horizontally should also be checked for turning moments and loads between the rod bearing and piston to ensure they are not excessive. Weight of oil must be included in determining bearing loads.

When specifying cylinders with stop tube be sure to call out the net stroke and the length of the stop tube. Machine design can be continued without delay by laying in a cylinder equivalent in length to the NET STROKE PLUS STOP TUBE LENGTH, which is referred to as GROSS STROKE.

Stop Tube Length vs Basic Length (L)

Pivot Mounts (BB, D, DB, DD, DE and SB)		Fixed Mounts (C, F, H, HB, HH, J, JB, JJ, TB, TC, TD)					
Pivoted and Rigidly Guided Rod End		Fixed & Rigidly Guided Rod End		Pivoted & Rigidly Guided Rod End		Unguided Rod End	
Basic Length (L)	Stop Tube Length	Basic Length (L)	Stop Tube Length	Basic Length (L)	Stop Tube Length	Basic Length (L)	Stop Tube Length
0 - 40	0	0 - 80	0	0 - 57	0	0 - 20	0
41 - 50	1	81 - 100	1	58 - 71	1	21 - 25	1
51 - 60	2	101 - 120	2	72 - 86	2	26 - 30	2
61 - 70	3	121 - 140	3	87 - 100	3	31 - 35	3
71 - 80	4	141 - 160	4	101 - 114	4	36 - 40	4
81 - 90	5	161 - 180	5	115 - 129	5	41 - 45	5
91 - 100	6	181 - 200	6	130 - 143	6	46 - 50	6
101 - 110	7	201 - 220	7	144 - 157	7	51 - 55	7
111 - 120	8	221 - 240	8	158 - 171	8	56 - 60	8
121 - 130	9	241 - 260	9	172 - 186	9	61 - 65	9
131 - 140	10	261 - 280	10	187 - 200	10	66 - 70	10
141 - 150	11	281 - 300	11	201 - 214	11	71 - 75	11
151 - 160	12			215 - 229	12	76 - 80	12
161 - 170	13			230 - 243	13	81 - 85	13
171 - 180	14			244 - 257	14	86 - 90	14
181 - 190	15			258 - 271	15	91 - 95	15
191 - 200	16			272 - 286	16	96 - 100	16
201 - 210	17			287 - 300	17	101 - 105	17
211 - 220	18					106 - 110	18
221 - 230	19					111 - 115	19
231 - 240	20					116 - 120	20
241 - 250	21					121 - 125	21
251 - 260	22					126 - 130	22
261 - 270	23					131 - 135	23
271 - 280	24					136 - 140	24
281 - 290	25					141 - 145	25
291 - 300	26					146 - 150	26
Consult Factory						Consult Factory	

Cylinder Mounting and Rod Guiding Groups

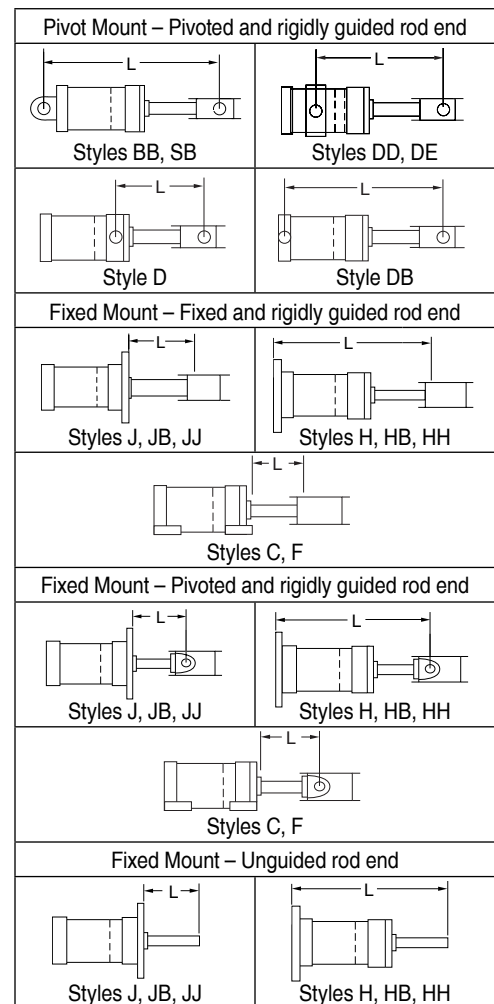

Piston Rod Diameter Selection

Long stroke cylinders that work on push with the piston rod loaded in compression should be checked, using the following steps, to ensure an appropriate piston rod diameter is specified.

1. First, determine whether stop tubing is required as described on the previous page.
2. Use the Basic Length (L) that was established for determining the stop tube length and then add the required stop tube length to the Basic Length to obtain an Adjusted Basic Length (L_A).
3. In the table below, for the mounting style and rod end guiding condition that will be used, find the row for the Bore and Rod combination that is required.
4. Follow the Bore and Rod row to the right and find the Operating Pressure column that is closest, but

exceeds the system pressure. The intersection of the Bore and Rod row and Operating Pressure column displays the maximum allowable L_A. If L_A in the table is greater than or equal to the calculated L_A, the rod diameter selected is satisfactory for the application.

5. If L_A in the table is less than the calculated Adjusted Basic Length move down the column to a rod diameter with an L_A that exceeds the requirement.
6. If the L_A specifies a rod diameter in a larger bore then restart the process of sizing the stop tube and re-check the rod diameter. Contact the factory if L_A exceeds 300 inches.

Note: Data in these tables assume standard rod extension (W dimension) and standard rod end accessories. If different, consult factory.

Maximum Basic Lengths (L_A) (all dimensions in inches)

Bore Ø	Rod Ø	Front and Side Fixed Mounts (J ¹ , JB ¹ , JJ, TB, TD, C, F)																		
		Fixed and Rigidly Guided Rod End Max. Allowable Basic Length (L _A) at psi:						Pivoted and Rigidly Guided Rod End Max. Allowable Basic Length (L _A) at psi:						Unguided Rod End Max. Allowable Basic Length (L _A) at psi:						
		500	1000	1500	2000	2500	3000	500	1000	1500	2000	2500	3000	500	1000	1500	2000	2500	3000	
1.50	0.625	50	35	29	25	22	20	36	25	21	18	16	15	13	9	7	6	6	5	
	1.000	128	91	74	64	57	52	92	65	53	46	41	37	32	23	19	16	14	13	
2.00	1.000	96	68	56	48	43	39	69	49	40	34	31	28	24	17	14	12	11	10	
	1.375	182	129	105	91	81	74	130	92	75	65	58	53	45	32	26	23	20	19	
2.50	1.000	77	54	44	38	34	31	55	39	32	27	25	22	19	14	11	10	9	8	
	1.375	146	103	84	73	65	59	104	73	60	52	46	42	36	26	21	18	16	15	
3.25	1.750	236	167	136	118	105	96	168	119	97	84	75	69	59	42	34	29	26	24	
	1.375	112	79	65	56	50	46	80	57	46	40	36	33	28	20	16	14	13	11	
4.00	1.750	181	128	105	91	81	74	130	92	75	65	58	53	45	32	26	23	20	19	
	2.000	237	167	137	118	106	97	169	120	98	85	76	69	59	42	34	30	26	24	
5.00	1.750	147	104	85	74	66	60	105	74	61	53	47	43	37	26	21	18	16	15	
	2.000	192	136	111	96	86	79	137	97	79	69	61	56	48	34	28	24	22	20	
6.00	2.500	300	213	174	150	134	123	215	152	124	107	96	88	75	53	43	38	34	31	
	2.000	154	109	89	77	69	63	110	78	63	55	49	45	38	27	22	19	17	16	
7.00	2.500	241	170	139	120	108	98	172	121	99	86	77	70	60	43	35	30	27	25	
	3.000	300	245	200	173	155	141	247	175	143	124	111	101	87	61	50	43	39	35	
8.00	3.500	300	300	272	236	211	192	300	238	194	168	151	137	118	83	68	59	53	48	
	2.500	200	142	116	100	90	82	143	101	83	72	64	58	50	35	29	25	22	20	
9.00	3.000	289	204	167	144	129	118	206	146	119	103	92	84	72	51	42	36	32	29	
	3.500	300	278	227	196	176	160	281	198	162	140	125	115	98	69	57	49	44	40	
10.00	4.000	300	300	296	257	229	209	300	259	212	183	164	150	128	91	74	64	57	52	
	3.000	247	175	143	124	111	101	177	125	102	88	79	72	62	44	36	31	28	25	
11.00	3.500	300	238	194	168	151	137	241	170	139	120	108	98	84	60	49	42	38	34	
	4.000	300	300	254	220	197	180	300	222	181	157	140	128	110	78	63	55	49	45	
12.00	4.500	300	300	300	278	249	227	300	281	230	199	178	162	139	98	80	70	62	57	
	5.000	300	300	300	300	300	281	300	300	283	245	220	200	172	121	99	86	77	70	
13.00	3.500	295	208	170	147	132	120	210	149	122	105	94	86	74	52	43	37	33	30	
	4.000	300	272	222	192	172	157	275	194	159	137	123	112	96	68	56	48	43	39	
14.00	4.500	300	300	281	244	218	199	300	246	201	174	156	142	122	86	70	61	54	50	
	5.000	300	300	300	300	269	245	300	300	248	215	192	175	150	106	87	75	67	61	
15.00	5.500	300	300	300	300	300	297	300	300	300	260	232	212	182	129	105	91	81	74	
	4.500	300	276	225	195	174	159	278	197	161	139	124	114	97	69	56	49	44	40	
16.00	5.000	300	300	278	241	215	196	300	243	198	172	154	140	120	85	69	60	54	49	
	5.500	300	300	300	291	260	238	300	294	240	208	186	170	146	103	84	73	65	59	
17.00	7.000	300	300	300	300	300	300	300	300	300	300	300	275	236	167	136	118	105	96	
	5.500	300	300	280	243	217	198	300	245	200	173	155	141	121	86	70	61	54	50	
18.00	7.000	300	300	300	300	300	300	300	300	300	300	281	251	229	196	139	113	98	88	80
	8.000	300	300	300	300	300	300	300	300	300	300	300	300	299	257	181	148	128	115	105
19.00	7.000	300	300	300	300	300	275	300	300	278	241	215	196	168	119	97	84	75	69	
	8.000	300	300	300	300	300	300	300	300	300	300	281	256	220	155	127	110	98	90	
20.00	10.000	300	300	300	300	300	300	300	300	300	300	300	300	300	243	198	172	154	140	
	8.000	300	300	300	300	300	300	300	300	300	300	275	246	224	192	136	111	96	86	79
21.00	9.000	300	300	300	300	300	300	300	300	300	300	300	300	284	244	172	141	122	109	99
	10.000	300	300	300	300	300	300	300	300	300	300	300	300	300	213	174	150	134	123	
22.00	9.000	300	300	300	300	300	300	300	300	300	300	277	252	216	153	125	108	97	88	
	10.000	300	300	300	300	300	300	300	300	300	300	300	300	267	189	154	134	120	109	
23.00	10.000	300	300	300	300	300	300	300	300	300	300	300	281	241	170	139	120	108	98	

¹ Maximum operating pressure is limited for Mounting Styles J and JB. Please refer to maximum operating pressure per bore in Pressure Ratings table located on the dimension page for each of these mounting styles.



Maximum Basic Lengths (L_A) (all dimensions in inches)

Bore Ø	Rod Ø	Rear Fixed Mounts (H ¹ , HB ¹ , HH, TC)																		
		Fixed and Rigidly Guided Rod End Max. Allowable Basic Length (L _A) at psi:						Pivoted and Rigidly Guided Rod End Max. Allowable Basic Length (L _A) at psi:						Unguided Rod End Max. Allowable Basic Length (L _A) at psi:						
		500	1000	1500	2000	2500	3000	500	1000	1500	2000	2500	3000	500	1000	1500	2000	2500	3000	
1.50	0.625	70	50	40	35	31	29	50	35	29	25	22	20	18	12	10	9	8	7	
	1.000	170	120	98	85	76	69	121	86	70	61	54	50	42	30	25	21	19	17	
2.00	1.000	132	93	76	66	59	54	94	67	54	47	42	38	33	23	19	16	15	13	
	1.375	232	164	134	116	104	95	166	117	96	83	74	68	58	41	33	29	26	24	
2.50	1.000	107	76	62	54	48	44	77	54	44	38	34	31	27	19	16	13	12	11	
	1.375	197	140	114	99	88	81	141	100	81	70	63	58	49	35	28	25	22	20	
	1.750	300	213	174	151	135	123	215	152	124	108	96	88	75	53	43	38	34	31	
3.25	1.375	156	110	90	78	70	64	111	79	64	56	50	45	39	28	22	19	17	16	
	1.750	246	174	142	123	110	100	176	124	102	88	79	72	62	44	36	31	28	25	
	2.000	300	221	181	157	140	128	224	158	129	112	100	91	78	55	45	39	35	32	
4.00	1.750	203	144	117	102	91	83	145	103	84	73	65	59	51	36	29	25	23	21	
	2.000	261	185	151	131	117	107	187	132	108	93	83	76	65	46	38	33	29	27	
5.00	2.500	300	274	224	194	173	158	277	196	160	138	124	113	97	69	56	48	43	40	
	2.000	214	151	123	107	96	87	153	108	88	76	68	62	53	38	31	27	24	22	
	2.500	300	231	188	163	146	133	233	165	135	117	104	95	82	58	47	41	36	33	
6.00	3.000	300	300	261	226	202	184	300	228	186	161	144	132	113	80	65	56	50	46	
	3.500	300	300	300	289	259	236	300	292	239	207	185	169	145	102	83	72	65	59	
	2.500	278	197	161	139	124	114	199	141	115	99	89	81	70	49	40	35	31	28	
	3.000	300	278	227	197	176	161	281	199	162	140	126	115	98	70	57	49	44	40	
	3.500	300	300	300	260	233	212	300	263	215	186	166	152	130	92	75	65	58	53	
7.00	4.000	300	300	300	300	292	266	300	300	269	233	208	190	163	115	94	82	73	67	
	3.000	300	241	197	171	153	139	244	172	141	122	109	100	85	60	49	43	38	35	
	3.500	300	300	263	228	204	186	300	230	188	163	146	133	114	81	66	57	51	46	
	4.000	300	300	300	289	259	236	300	292	239	207	185	169	145	102	83	72	65	59	
	4.500	300	300	300	300	300	288	300	300	290	252	225	205	176	124	102	88	79	72	
8.00	5.000	300	300	300	300	300	300	300	300	300	296	264	241	207	146	119	103	93	84	
	3.500	300	288	235	203	182	166	291	205	168	145	130	119	102	72	59	51	45	42	
	4.000	300	300	300	261	234	213	300	264	216	187	167	152	131	92	75	65	58	53	
	4.500	300	300	300	300	290	264	300	300	267	231	207	189	162	114	93	81	72	66	
	5.000	300	300	300	300	300	300	300	300	300	277	248	226	194	137	112	97	87	79	
10.00	5.500	300	300	300	300	300	300	300	300	300	300	289	264	226	160	131	113	101	92	
	4.500	300	300	300	269	241	220	300	272	222	192	172	157	135	95	78	67	60	55	
	5.000	300	300	300	300	300	300	300	300	300	300	300	300	296	209	171	148	132	121	
	5.500	300	300	300	300	294	268	300	300	271	235	210	192	164	116	95	82	73	67	
12.00	7.000	300	300	300	300	300	300	300	300	300	280	250	229	196	139	113	98	88	80	
	5.500	300	300	300	300	299	273	300	300	276	239	213	195	167	118	96	84	75	68	
	7.000	300	300	300	300	300	300	300	300	300	300	300	300	300	231	189	163	146	133	
14.00	8.000	300	300	300	300	300	300	300	300	300	300	300	300	300	260	184	150	130	116	106
	7.000	300	300	300	300	300	300	300	300	300	300	300	291	266	228	161	132	114	102	93
	8.000	300	300	300	300	300	300	300	300	300	300	300	300	300	293	240	207	186	169	157
16.00	10.000	300	300	300	300	300	300	300	300	300	300	300	300	300	290	205	167	145	129	118
	8.000	300	300	300	300	300	300	300	300	300	300	300	300	300	260	184	150	130	116	106
	9.000	300	300	300	300	300	300	300	300	300	300	300	300	300	227	186	161	144	131	119
18.00	10.000	300	300	300	300	300	300	300	300	300	300	300	300	300	272	222	192	172	157	144
	9.000	300	300	300	300	300	300	300	300	300	300	300	300	300	293	207	169	146	131	119
20.00	10.000	300	300	300	300	300	300	300	300	300	300	300	300	300	250	204	177	158	144	133
	10.000	300	300	300	300	300	300	300	300	300	300	300	300	300	231	188	163	146	133	121

¹ Maximum operating pressure is limited for Mounting Styles H and HB. Please refer to maximum operating pressure per bore in Pressure Ratings table located on the dimension page for each of these mounting styles.



Maximum Basic Lengths (L_A) (all dimensions in inches)

Bore Ø	Rod Ø	Rear Pivot Mounts (BB, SB ¹ , DB)						Front and Intermediate Pivot Mounts (D, DD, DE)					
		Pivoted & Rigidly Guided Rod End Max. Allowable Basic Length (L _A) at psi:						Pivoted & Rigidly Guided Rod End Max. Allowable Basic Length (L _A) at psi:					
		500	1000	1500	2000	2500	3000	500	1000	1500	2000	2500	3000
1.50	0.625	35	25	20	18	16	14	25	18	14	13	11	10
	1.000	85	60	49	42	38	35	64	45	37	32	29	26
2.00	1.000	66	47	38	33	29	27	48	34	28	24	22	20
	1.375	116	82	67	58	52	47	91	64	53	45	41	37
2.50	1.000	54	38	31	27	24	22	38	27	22	19	17	16
	1.375	99	70	57	49	44	40	73	51	42	36	33	30
3.25	1.750	151	106	87	75	67	61	118	83	68	59	53	48
	1.375	78	55	45	39	35	32	56	40	32	28	25	23
4.00	1.750	123	87	71	62	55	50	91	64	52	45	41	37
	2.000	157	111	90	78	70	64	118	84	68	59	53	48
5.00	1.750	102	72	59	51	45	41	74	52	43	37	33	30
	2.000	131	92	75	65	58	53	96	68	56	48	43	39
6.00	2.500	194	137	112	97	87	79	150	106	87	75	67	61
	2.000	107	76	62	53	48	44	77	54	44	38	34	31
7.00	2.500	163	115	94	82	73	67	120	85	69	60	54	49
	3.000	226	160	130	113	101	92	173	122	100	87	77	71
8.00	3.500	289	204	167	145	129	118	236	167	136	118	105	96
	2.500	139	98	80	70	62	57	100	71	58	50	45	41
9.00	3.000	197	139	114	98	88	80	144	102	83	72	65	59
	3.500	260	184	150	130	116	106	196	139	113	98	88	80
10.00	4.000	300	231	188	163	146	133	257	181	148	128	115	105
	3.000	171	121	99	85	76	70	124	87	71	62	55	50
11.00	3.500	228	161	132	114	102	93	168	119	97	84	75	69
	4.000	289	204	167	145	129	118	220	155	127	110	98	90
12.00	4.500	300	249	203	176	157	144	278	197	161	139	124	114
	5.000	300	293	239	207	185	169	300	243	198	172	154	140
13.00	3.500	203	144	117	102	91	83	147	104	85	74	66	60
	4.000	261	185	151	131	117	107	192	136	111	96	86	79
14.00	4.500	300	229	187	162	145	132	244	172	141	122	109	99
	5.000	300	274	224	194	174	158	300	213	174	150	134	123
15.00	5.500	300	300	261	226	202	185	300	257	210	182	163	149
	4.500	269	190	155	135	120	110	195	138	112	97	87	80
16.00	5.000	300	300	300	296	265	242	241	170	139	120	108	98
	5.500	300	232	190	164	147	134	291	206	168	146	130	119
17.00	7.000	300	277	226	196	175	160	300	300	272	236	211	192
	5.500	300	236	193	167	149	136	243	171	140	121	108	99
18.00	7.000	300	300	300	300	292	267	300	278	227	196	176	160
	8.000	300	300	300	260	233	213	300	300	296	257	229	209
19.00	7.000	300	300	263	228	204	186	300	238	194	168	151	137
	8.000	300	300	300	300	300	300	300	300	254	220	197	180
20.00	10.000	300	300	300	290	259	236	300	300	300	300	300	281
	8.000	300	300	300	260	233	213	300	272	222	192	172	157
21.00	9.000	300	300	300	300	288	263	300	300	281	244	218	199
	10.000	300	300	300	300	300	300	300	300	300	300	269	245
22.00	9.000	300	300	300	293	262	239	300	300	250	216	194	177
	10.000	300	300	300	300	300	289	300	300	300	267	239	218
23.00	10.000	300	300	300	300	292	267	300	300	278	241	215	196

¹ Maximum operating pressure is limited for Mounting Style SB. Please refer to maximum operating pressure per bore in Pressure Ratings table located on the dimension page for Mounting Styles SB.



An Introduction to Cushioning

Cushioning is recommended as a means of controlling the deceleration of masses, or for applications where piston speed is in excess of 4 in/sec and the piston will make full stroke. Cushioning extends cylinder life and reduces undesirable noise and hydraulic shock. Built-in “cushions” are optional and can be supplied at the head and cap ends of a cylinder without affecting its envelope or mounting dimensions.

Standard Cushioning

Ideal cushion performance shows an almost uniform absorption of energy along the cushioning length, as shown. Many forms of cushioning exist, and each has its own specific merits and advantages.

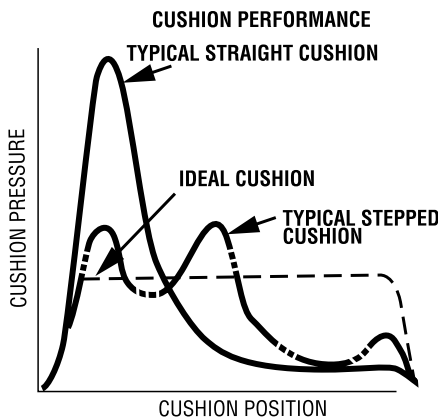

In order to cover the majority of applications, 2H/3H cylinders are supplied with profiled cushioning as standard. Final speed may be adjusted using the cushion screw. The performance of profiled cushioning is indicated on the diagram, and

cushion performance for each of the rod sizes available is illustrated graphically in the charts on the following pages.

Note: Cushion performance will be affected by the use of water or high water based fluids. Please consult factory for details.

Cushion Length

Where specified, 2H/3H cylinder incorporates the longest cushion sleeve and spear that can be accommodated within the standard envelope without reducing the rod bearing and piston bearing length. See cushion lengths on the next page. Cushions are adjustable via recessed needle valves.

Cushion Calculation

The charts on the cushion energy absorption capacity data page show the energy absorption capacity for each bore/rod combination at the head (annulus) and the cap (full bore) ends of cylinder. The charts are valid for piston velocities within a range of 0.33 to 1 ft/s. For velocities between 1ft/s and 1.64 ft/s the energy values derived from the charts should be reduced by 25%. For velocities less than 0.33 ft/s where large masses are involved, and for velocities greater than 1.60 ft/s, a special cushion profile may be required. Please consult the factory for details.

The cushion capacity of the head end is less than the cap, and reduces to zero at high drive pressures due to the pressure intensification effect across the piston.

The energy absorption capacity of the cushion decreases with drive pressure.

Formula

Cushioning calculations are based on the formula $E=(1/2)mv^2$ for horizontal applications. For inclined or vertically downward or upward applications, this is modified to:

$$E = (1/2)mv^2 + mg(L/12) \times \sin(a)$$

(for inclined or vertically downward direction of mass)

$$E = (1/2)mv^2 - mg(L/12) \times \sin(a)$$

(for inclined vertically upward direction of mass)

where:

E = energy absorbed in ft-lb

g = acceleration due to gravity = 32.2 ft/s²

v = velocity in ft/s

L = length of cushion in inches (see cushion length chart on the next page).

m = mass of load in slug (including piston, rod and rod end accessories).

a = angle to the horizontal in degrees

p = pressure in psi

Example:

The following example shows how to calculate the energy developed by masses moving in a straight line. For non-linear motion, other calculations are required; please consult the factory. The example assumes that the bore and rod diameter are already appropriate for the application. The effects of friction on the cylinder and load have been ignored.

Selected bore/rod 6.00" bore x 2.50" rod (No. 1 rod)

Cushion at the cap end.

Pressure = 2,500 psi

Mass = 685 slugs = weight in lb / (32.2 ft/s²)

Velocity = 1.3 ft/s

Cushion length = 1.313 inch

a = 45°

Sin (a) = 0.70

$$E = (1/2)mv^2 + mgl/12 \times \sin(a)$$

$$= (1/2) \times 685 \times 1.3^2 + 685 \times 32.2 \times 1.313/12 \times 0.70$$

$$= 2,268 \text{ ft-lb}$$

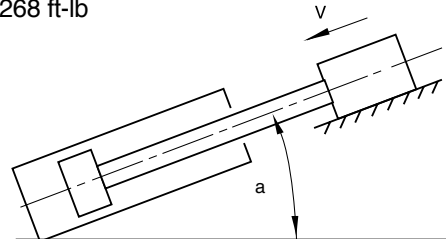

Note: In the above example velocity is greater than 1 ft/s. Therefore, a de-rating factor of 0.75 must be applied to the calculated value of E. Applying this correction factor will increase the energy value to 3024 ft-lb (2268/0.75 = 3024 ft-lb). A review of the graph for the cap end cushion of a 6 inch bore x 2.50" rod cylinder operating at 2500 psi indicates that it can absorb approximately 3200 ft-lb maximum of energy. Since 3024 ft-lb is less than the maximum allowable of 3200 ft-lb, the cylinder can be applied as indicated. If the calculated energy exceeds the value shown on the curve, select a larger bore cylinder and/or reduce the operating pressure and recalculate the energy. Compare the newly calculated energy value to the appropriate curve to ensure it does not exceed the maximum allowable energy.

Cushion Length Chart (Series 2H/3H Cylinders)

Bore Ø	Rod Ø	Effective Cushion Length	
		Head	Cap
1.50	0.625	0.924	1.000
	1.000	0.927	1.000
2.00	1.000	0.927	0.938
	1.375	0.925	0.938
2.50	1.000	0.927	0.938
	1.750	0.928	0.938
	1.375	0.925	0.938
3.25	1.375	1.175	1.125
	2.000	0.862	1.125
	1.750	1.178	1.125
4.00	1.750	1.178	1.063
	2.500	0.869	1.063
	2.000	0.862	1.063
5.00	2.000	0.862	0.938
	3.500	0.869	0.938
	2.500	0.869	0.938
	3.000	0.869	0.938
6.00	2.500	1.119	1.313
	4.000	1.119	1.313
	3.000	1.119	1.313
	3.500	0.869	1.313
7.00	3.000	1.619	1.750
	5.000	1.496	1.750
	3.500	1.619	1.750
	4.000	1.119	1.750
	4.500	1.496	1.750
8.00	3.500	1.869	1.813
	5.500	1.745	1.813
	4.000	1.119	1.813
	4.500	1.496	1.813
	5.000	1.496	1.813

Cushion Energy Absorption Capacity Data

The cushion energy absorption data shown below is based on the maximum fatigue-free pressure developed in the tube. For application with a life cycle of less than 10⁶ cycles, greater

energy absorption figures can be applied. Please consult the factory if further information is required.

Head End

STANDARD ROD DIA.

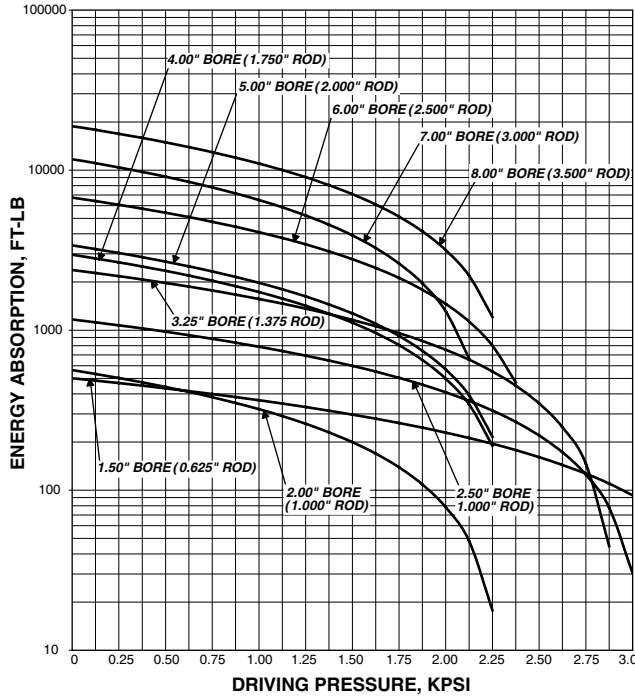

MAXIMUM ROD DIA.

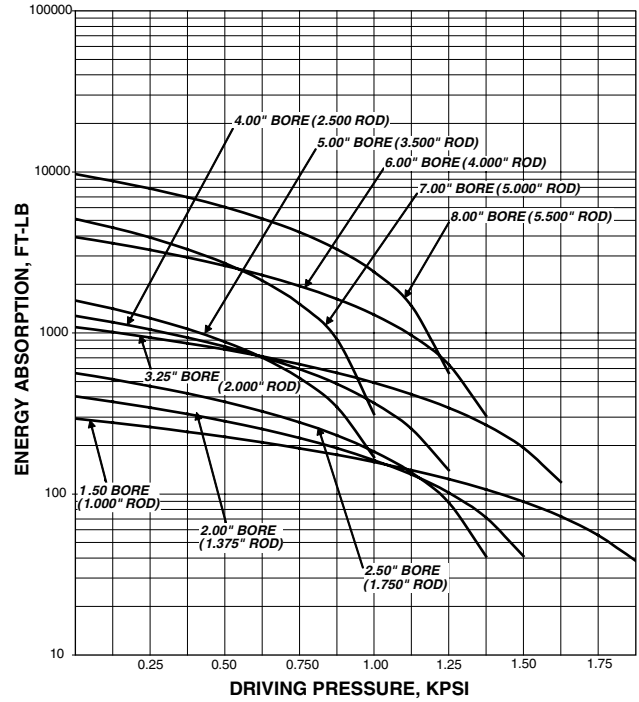

FIRST OVERSIZE ROD DIA.

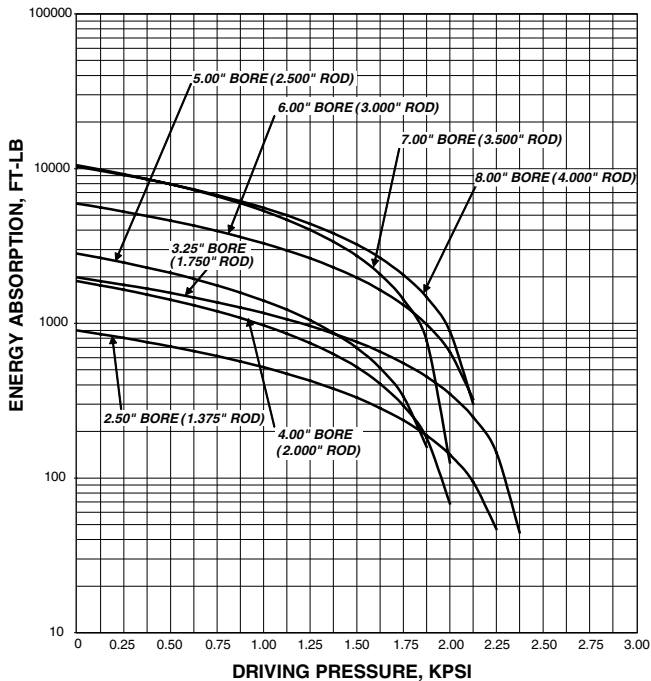

SECOND OVERSIZE ROD DIA.

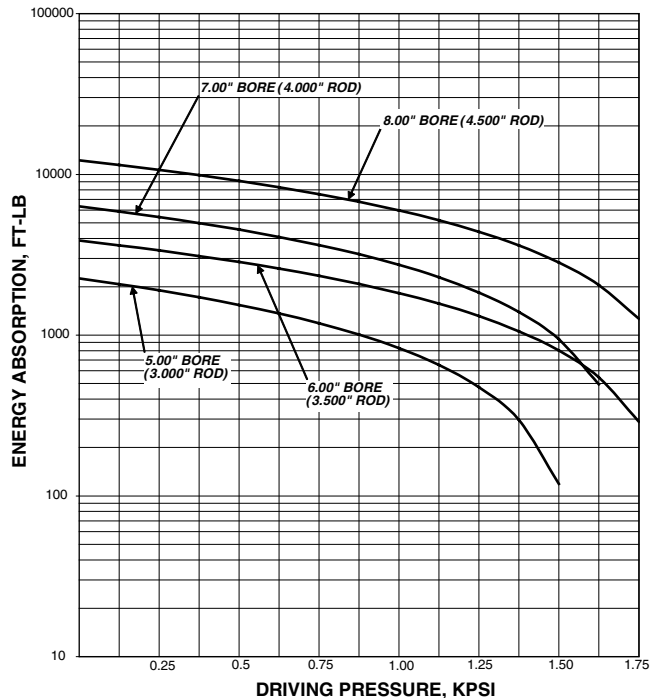

Cushion Energy Absorption Capacity Data

The cushion energy absorption data shown below is based on the maximum fatigue-free pressure developed in the tube. For application with a life cycle of less than 10⁶ cycles, greater

energy absorption figures can be applied. Please consult the factory if further information is required.

Head End

THIRD OVERSIZE ROD DIA.

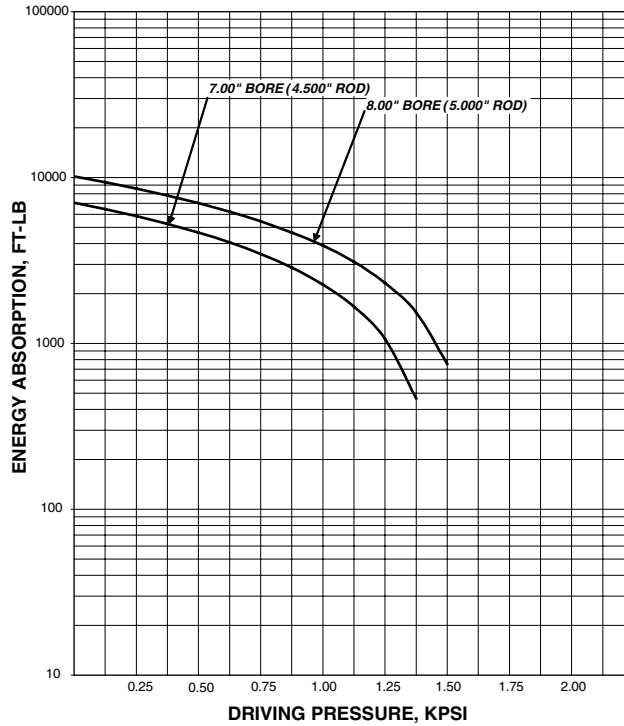

Cushion Energy Absorption Capacity Data

The cushion energy absorption data shown below is based on the maximum fatigue-free pressure developed in the tube. For application with a life cycle of less than 10^6 cycles, greater

energy absorption figures can be applied. Please consult the factory if further information is required.

Cap End

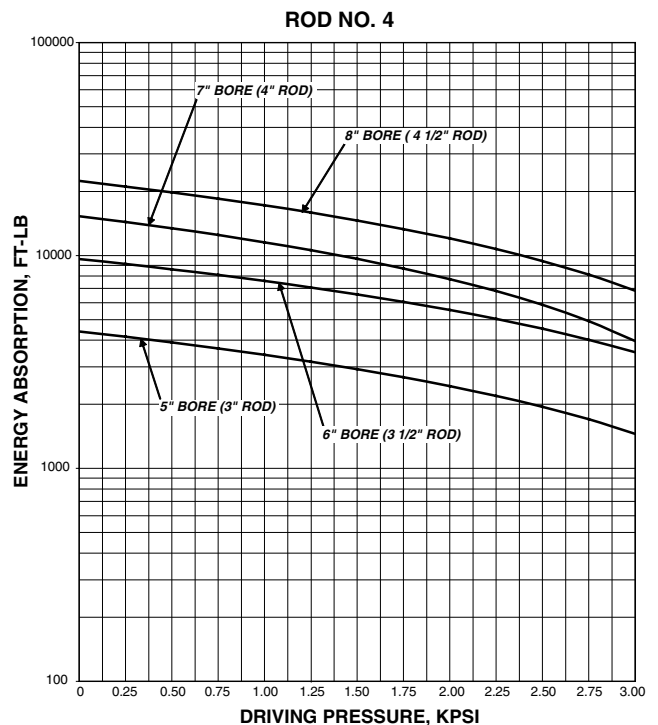
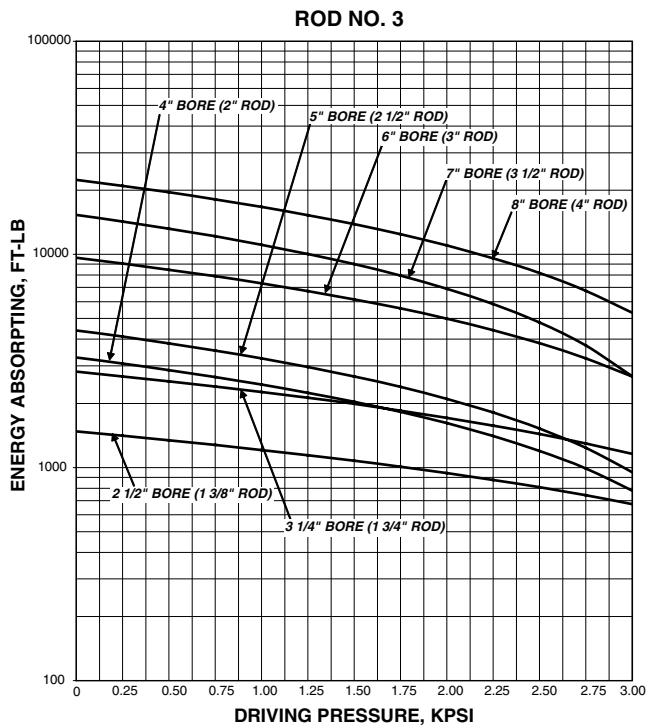
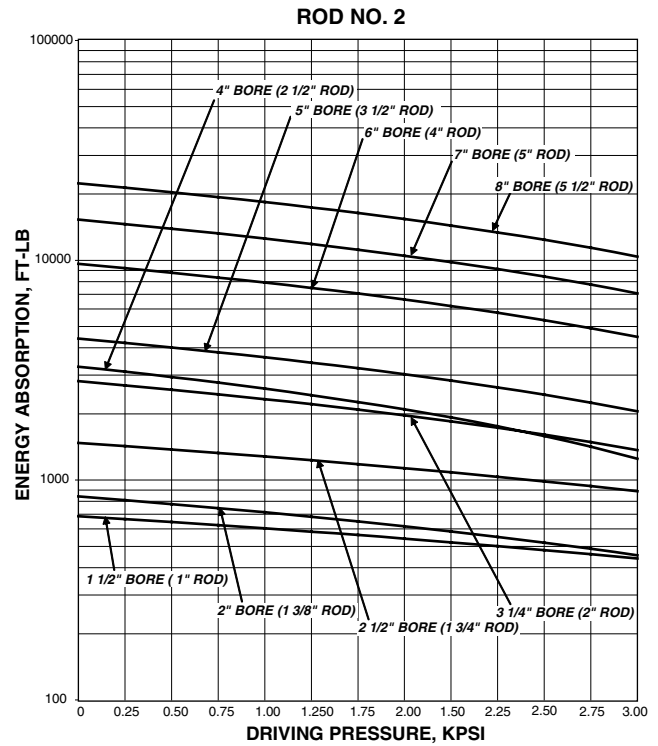
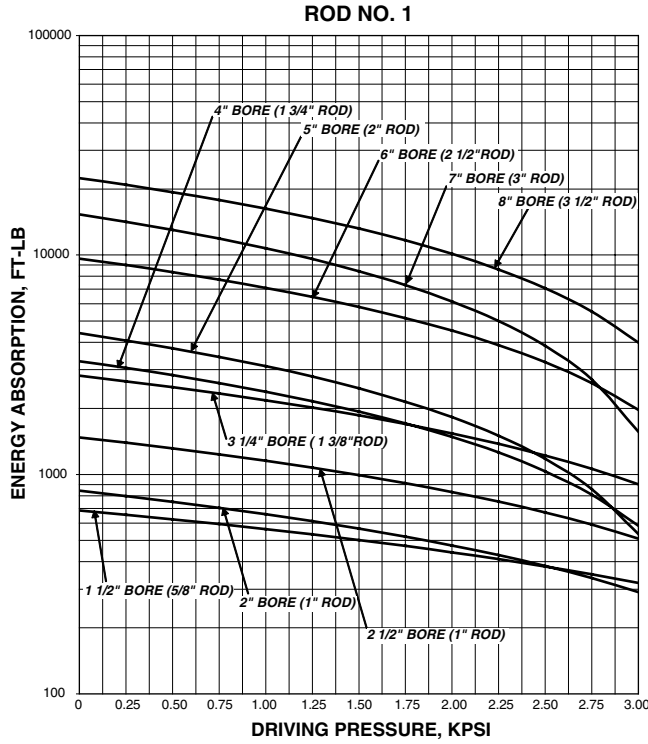

Cushion Energy Absorption Capacity Data

The cushion energy absorption data shown below is based on the maximum fatigue-free pressure developed in the tube. For application with a life cycle of less than 10^6 cycles, greater

energy absorption figures can be applied. Please consult the factory if further information is required.

Cap End

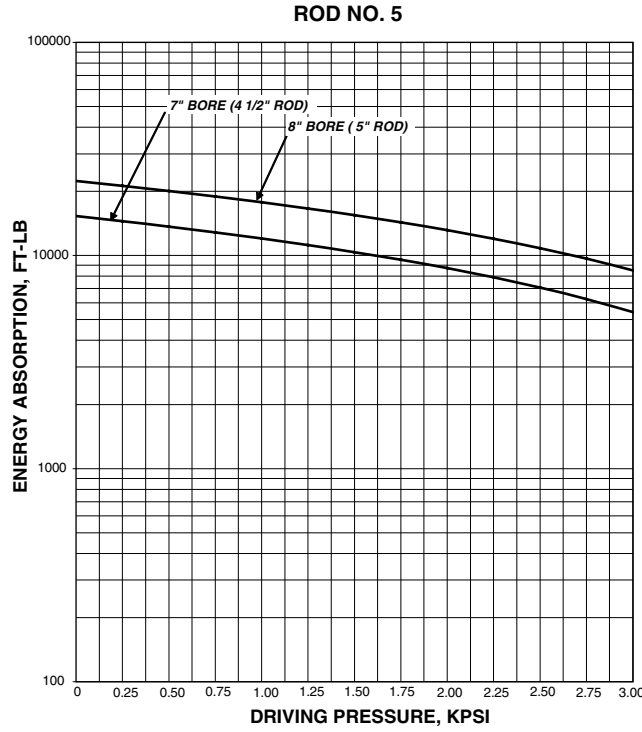

Manufacturing Locations

Regional Plants

California

221 Helicopter Circle
Corona, CA 92880
Tel.: (951) 280-3800
Fax: (951) 280-3808
Fax: (800) 869-9886

Connecticut

80 Shaker Road
Enfield, CT 06082
Tel.: (860) 749-2215
Fax: (800) 323-0105

Georgia

1300 Six Flags Road
Lithia Springs, GA 30122
Tel.: (770) 819-3400
Fax: (800) 437-3498

Indiana

Goodland Plant
715 South Iroquois Street
Goodland, IN 47948
Tel.: (219) 297-3182
Fax: (800) 328-8120

Michigan

900 Plymouth Road
Plymouth, MI 48170
Tel.: (734) 455-1700
Fax: (734) 455-1007

Oregon

29289 Airport Road
Eugene, OR 97402-0079
Tel.: (541) 689-9111
Fax: (541) 688-6771
Fax: (800) 624-7996

Safety Guide for Selecting and Using Hydraulic, Pneumatic Cylinders and Their Accessories

WARNING: ⚠ FAILURE OF THE CYLINDER, ITS PARTS, ITS MOUNTING, ITS CONNECTIONS TO OTHER OBJECTS, OR ITS CONTROLS CAN RESULT IN:

- Unanticipated or uncontrolled movement of the cylinder or objects connected to it.
- Falling of the cylinder or objects held up by it.
- Fluid escaping from the cylinder, potentially at high velocity.

THESE EVENTS COULD CAUSE DEATH OR PERSONAL INJURY BY, FOR EXAMPLE, PERSONS FALLING FROM HIGH LOCATIONS, BEING CRUSHED OR STRUCK BY HEAVY OR FAST MOVING OBJECTS, BEING PUSHED INTO DANGEROUS EQUIPMENT OR SITUATIONS, OR SLIPPING ON ESCAPED FLUID.

Before selecting or using Parker Hannifin Corporation (the Company) cylinders or related accessories, it is important that you read, understand and follow the following safety information. Training is advised before selecting and using the Company's products.

1.0 General Instructions

1.1 Scope – This safety guide provides instructions for selecting and using (including assembling, installing, and maintaining) cylinder products. This safety guide is a supplement to and is to be used with the specific Company publications for the specific cylinder products that are being considered for use.

1.2 Fail Safe – Cylinder products can and do fail without warning for many reasons. All systems and equipment should be designed in a fail-safe mode so that if the failure of a cylinder product occurs people and property won't be endangered.

1.3 Distribution – Provide a free copy of this safety guide to each person responsible for selecting or using cylinder products. Do not select or use the Company's cylinders without thoroughly reading and understanding this safety guide as well as the specific Company publications for the products considered or selected.

1.4 User Responsibility – Due to very wide variety of cylinder applications and cylinder operating conditions, the Company does not warrant that any particular cylinder is suitable for any specific application. This safety guide does not analyze all technical parameters that must be considered in selecting a product. The hydraulic and pneumatic cylinders outlined in this catalog are designed to the Company's design guidelines and do not necessarily meet the design guideline of other agencies such as American Bureau of Shipping, ASME Pressure Vessel Code etc. The user, through its own analysis and testing, is solely responsible for:

- Making the final selection of the cylinders and related accessories.
- Determining if the cylinders are required to meet specific design requirements as required by the Agency(s) or industry standards covering the design of the user's equipment.
- Assuring that the user's requirements are met, OSHA requirements are met, and safety guidelines from the applicable agencies such as but not limited to ANSI are followed and that the use presents no health or safety hazards.
- Providing all appropriate health and safety warnings on the equipment on which the cylinders are used.

1.5 Additional Questions – Call the appropriate Company technical service department if you have any questions or require any additional information. See the Company publication for the product being considered or used, or call 1-847-298-2400, or go to www.parker.com, for telephone numbers of the appropriate technical service department.

2.0 Cylinder and Accessories Selection

2.1 Seals – Part of the process of selecting a cylinder is the selection of seal compounds. Before making this selection, consult the "seal information page(s)" of the publication for the series of cylinders of interest.

The application of cylinders may allow fluids such as cutting fluids, wash down fluids etc. to come in contact with the external area of the cylinder. These fluids may attack the piston rod wiper and or the primary seal and must be taken into account when selecting and specifying seal compounds.

Dynamic seals will wear. The rate of wear will depend on many operating factors. Wear can be rapid if a cylinder is mis-aligned or if the cylinder has been improperly serviced. The user must take seal wear into consideration in the application of cylinders.

2.2 Piston Rods – Possible consequences of piston rod failure or separation of the piston rod from the piston include, but are not limited to are:

- Piston rod and or attached load thrown off at high speed.
- High velocity fluid discharge.
- Piston rod extending when pressure is applied in the piston retract mode.

Piston rods or machine members attached to the piston rod may move suddenly and without warning as a consequence of other conditions occurring to the machine such as, but not limited to:

- Unexpected detachment of the machine member from the piston rod.

- Failure of the pressurized fluid delivery system (hoses, fittings, valves, pumps, compressors) which maintain cylinder position.
- Catastrophic cylinder seal failure leading to sudden loss of pressurized fluid.
- Failure of the machine control system.

Follow the recommendations of the "Piston Rod Selection Chart and Data" in the publication for the series of cylinders of interest. The suggested piston rod diameter in these charts must be followed in order to avoid piston rod buckling.

Piston rods are not normally designed to absorb bending moments or loads which are perpendicular to the axis of piston rod motion. These additional loads can cause the piston rod to fail. If these types of additional loads are expected to be imposed on the piston rod, their magnitude should be made known to our engineering department.

The cylinder user should always make sure that the piston rod is securely attached to the machine member.

On occasion cylinders are ordered with double rods (a piston rod extended from both ends of the cylinder). In some cases a stop is threaded on to one of the piston rods and used as an external stroke adjuster. On occasions spacers are attached to the machine member connected to the piston rod and also used as a stroke adjuster. In both cases the stops will create a pinch point and the user should consider appropriate use of guards. If these external stops are not perpendicular to the mating contact surface, or if debris is trapped between the contact surfaces, a bending moment will be placed on the piston rod, which can lead to piston rod failure. An external stop will also negate the effect of cushioning and will subject the piston rod to impact loading. Those two (2) conditions can cause piston rod failure. Internal stroke adjusters are available with and without cushions. The use of external stroke adjusters should be reviewed with our engineering department.

The piston rod to piston and the stud to piston rod threaded connections are secured with an anaerobic adhesive. The strength of the adhesive decreases with increasing temperature. Cylinders which can be exposed to temperatures above +250°F (+121°C) are to be ordered with a non studded piston rod and a pinned piston rod joint.

2.3 Cushions – Cushions should be considered for cylinder applications when the piston velocity is expected to be over 4 inches/second.

Cylinder cushions are normally designed to absorb the energy of a linear applied load. A rotating mass has considerably more energy than the same mass moving in a linear mode. Cushioning for a rotating mass application should be reviewed by our engineering department.

2.4 Cylinder Mountings – Some cylinder mounting configurations may have certain limitations such as but not limited to minimum stroke for side or foot mounting cylinders or pressure de-ratings for certain mounts. Carefully review the catalog for these types of restrictions.

Always mount cylinders using the largest possible high tensile alloy steel socket head cap screws that can fit in the cylinder mounting holes and torque them to the manufacturer's recommendations for their size.

2.5 Port Fittings – Hydraulic cylinders applied with meter out or deceleration circuits are subject to intensified pressure at piston rod end.

The rod end pressure is approximately equal to:

$$\frac{\text{operating pressure} \times \text{effective cap end area}}{\text{effective rod end piston area}}$$

Contact your connector supplier for the pressure rating of individual connectors.

3.0 Cylinder and Accessories Installation and Mounting

3.1 Installation

3.1.1 – Cleanliness is an important consideration, and cylinders are shipped with the ports plugged to protect them from contaminants entering the ports. These plugs should not be removed until the piping is to be installed. Before making the connection to the cylinder ports, piping should be thoroughly cleaned to remove all chips or burrs which might have resulted from threading or flaring operations.

3.1.2 – Cylinders operating in an environment where air drying materials are present such as fast-drying chemicals, paint, or weld splatter, or other hazardous conditions such as excessive heat, should have shields installed to prevent damage to the piston rod and piston rod seals.

3.1.3 – Proper alignment of the cylinder piston rod and its mating component on the machine should be checked in both the extended and retracted positions. Improper alignment will result in excessive rod gland and/or cylinder bore wear. On fixed mounting cylinders attaching the piston rod while the rod is retracted will help in achieving proper alignment.

3.1.4 – Sometimes it may be necessary to rotate the piston rod in order to thread the piston rod into the machine member. This operation must always be done with zero pressure being applied to either side of the piston. Failure to follow this procedure may result in loosening the piston to rod-threaded connection. In some rare cases the turning of the piston rod may rotate a threaded piston rod gland and loosen it from the cylinder head. Confirm that this condition is not occurring. If it does, re-tighten the piston rod gland firmly against the cylinder head.

For double rod cylinders it is also important that when attaching or detaching the piston rod from the machine member that the torque be applied to the piston rod end of the cylinder that is directly attaching to the machine member with the opposite end unrestrained. If the design of the machine is such that only the rod end of the cylinder opposite to where the rod attaches to the machine member can be rotated, consult the factory for further instructions.

3.2 Mounting Recommendations

3.2.1 – Always mount cylinders using the largest possible high tensile alloy steel socket head screws that can fit in the cylinder mounting holes and torque them to the manufacturer's recommendations for their size.

3.2.2 – Side-Mounted Cylinders – In addition to the mounting bolts, cylinders of this type should be equipped with thrust keys or dowel pins located so as to resist the major load.

3.2.3 – Tie Rod Mounting – Cylinders with tie rod mountings are recommended for applications where mounting space is limited. The standard tie rod extension is shown as BB in dimension tables. Longer or shorter extensions can be supplied. Nuts used for this mounting style should be torqued to the same value as the tie rods for that bore size.

3.2.4 – Flange Mount Cylinders – The controlled diameter of the rod gland extension on head end flange mount cylinders can be used as a pilot to locate the cylinders in relation to the machine. After alignment has been obtained, the flanges may be drilled for pins or dowels to prevent shifting.

3.2.5 – Trunnion Mountings – Cylinders require lubricated bearing blocks with minimum bearing clearances. Bearing blocks should be carefully aligned and rigidly mounted so the trunnions will not be subjected to bending moments. The rod end should also be pivoted with the pivot pin in line and parallel to axis of the trunnion pins.

3.2.6 – Clevis Mountings – Cylinders should be pivoted at both ends with centerline of pins parallel to each other. After cylinder is mounted, be sure to check to assure that the cylinder is free to swing through its working arc without interference from other machine parts.

4.0 Cylinder and Accessories Maintenance, Troubleshooting and Replacement

4.1 Storage – At times cylinders are delivered before a customer is ready to install them and must be stored for a period of time. When storage is required the following procedures are recommended.

4.1.1 – Store the cylinders in an indoor area which has a dry, clean and noncorrosive atmosphere. Take care to protect the cylinder from both internal corrosion and external damage.

4.1.2 – Whenever possible cylinders should be stored in a vertical position (piston rod up). This will minimize corrosion due to possible condensation which could occur inside the cylinder. This will also minimize seal damage.

4.1.3 – Port protector plugs should be left in the cylinder until the time of installation.

4.1.4 – If a cylinder is stored full of hydraulic fluid, expansion of the fluid due to temperature changes must be considered. Installing a check valve with free flow out of the cylinder is one method.

4.1.5 – When cylinders are mounted on equipment that is stored outside for extended periods, exposed unpainted surfaces, e.g. piston rod, must be coated with a rust-inhibiting compound to prevent corrosion.

4.2 Cylinder Trouble Shooting

4.2.1 – External Leakage

4.2.1.1 – Rod seal leakage can generally be traced to worn or damaged seals. Examine the piston rod for dents, gouges or score marks, and replace piston rod if surface is rough.

Rod seal leakage could also be traced to gland wear. If clearance is excessive, replace rod bushing and seal. Rod seal leakage can also be traced to seal deterioration. If seals are soft or gummy or brittle, check compatibility of seal material with lubricant used if air cylinder, or operating fluid if hydraulic cylinder. Replace with seal material, which is compatible with these fluids. If the seals are hard or have lost elasticity, it is usually due to exposure to temperatures in excess of 165°F. (+74°C). Shield the cylinder from the heat source to limit temperature to 350°F. (+177°C.) and replace with fluorocarbon seals.

4.2.1.2 – Cylinder body seal leak can generally be traced to loose tie rods. Torque the tie rods to manufacturer's recommendation for that bore size.

Excessive pressure can also result in cylinder body seal leak. Determine maximum pressure to rated limits. Replace seals and retorque tie rods as in paragraph above. Excessive pressure can also result in cylinder body seal leak. Determine if the pressure rating of the cylinder has been exceeded. If so, bring the operating pressure down to the rating of the cylinder and have the tie rods replaced.

Pinched or extruded cylinder body seal will also result in a leak. Replace cylinder body seal and retorque as in paragraph above.

Cylinder body seal leakage due to loss of radial squeeze which shows up in the form of flat spots or due to wear on the O.D. or I.D. – Either of these are symptoms of normal wear due to high cycle rate or length of service. Replace seals as per paragraph above.

4.2.2 – Internal Leakage

4.2.2.1 – Piston seal leak (by-pass) 1 to 3 cubic inches per minute leakage is considered normal for piston ring construction. Virtually no static leak with lipseal type seals on piston should be expected. Piston seal wear is a usual cause of piston seal leakage. Replace seals as required.

4.2.2.2 – With lipseal type piston seals excessive back pressure due to over-adjustment of speed control valves could be a direct cause of rapid seal wear. Contamination in a hydraulic system can result in a scored cylinder bore, resulting in rapid seal wear. In either case, replace piston seals as required.

4.2.2.3 – What appears to be piston seal leak, evidenced by the fact that the cylinder drifts, is not always traceable to the piston. To make sure, it is suggested that one side of the cylinder piston be pressurized and the fluid line at the opposite port be disconnected. Observe leakage. If none is evident, seek the cause of cylinder drift in other component parts in the circuit.

4.2.3 – Cylinder Fails to Move the Load

4.2.3.1 – Pneumatic or hydraulic pressure is too low. Check the pressure at the cylinder to make sure it is to circuit requirements.

4.2.3.2 – Piston Seal Leak – Operate the valve to cycle the cylinder and observe fluid flow at valve exhaust ports at end of cylinder stroke. Replace piston seals if flow is excessive.

4.2.3.3 – Cylinder is undersized for the load – Replace cylinder with one of a larger bore size.

4.3 Erratic or Chatter Operation

4.3.1 – Excessive friction at rod gland or piston bearing due to load misalignment – Correct cylinder-to-load alignment.

4.3.2 – Cylinder sized too close to load requirements – Reduce load or install larger cylinder.

4.3.3 – Erratic operation could be traced to the difference between static and kinetic friction. Install speed control valves to provide a back pressure to control the stroke.

4.4 Cylinder Modifications, Repairs, or Failed Component – Cylinders as shipped from the factory are not to be disassembled and or modified. If cylinders require modifications, these modifications must be done at company locations or by the Company's certified facilities. The Industrial Cylinder Division Engineering Department must be notified in the event of a mechanical fracture or permanent deformation of any cylinder component (excluding seals). This includes a broken piston rod, tie rod, mounting accessory or any other cylinder component. The notification should include all operation and application details. This information will be used to provide an engineered repair that will prevent recurrence of the failure.

It is allowed to disassemble cylinders for the purpose of replacing seals or seal assemblies. However, this work must be done by strictly following all the instructions provided with the seal kits.

Offer of Sale

The items described in this document and other documents and descriptions provided by Parker Hannifin Corporation, its subsidiaries and its authorized distributors ("Seller") are hereby offered for sale at prices to be established by Seller. This offer and its acceptance by any customer ("Buyer") shall be governed by all of the following Terms and Conditions. Buyer's order for any item described in its document, when communicated to Seller verbally, or in writing, shall constitute acceptance of this offer. All goods, services or work described will be referred to as "Products".

1. Terms and Conditions. Seller's willingness to offer Products, or accept an order for Products, to or from Buyer is subject to these Terms and Conditions or any newer version of the terms and conditions found on-line at www.parker.com/saleterms/. Seller objects to any contrary or additional terms or conditions of Buyer's order or any other document issued by Buyer.

2. Price Adjustments; Payments. Prices stated on Seller's quote or other documentation offered by Seller are valid for 30 days, and do not include any sales, use, or other taxes unless specifically stated. Unless otherwise specified by Seller, all prices are F.C.A. Seller's facility (INCOTERMS 2010). Payment is subject to credit approval and is due 30 days from the date of invoice or such other term as required by Seller's Credit Department, after which Buyer shall pay interest on any unpaid invoices at the rate of 1.5% per month or the maximum allowable rate under applicable law.

3. Delivery Dates; Title and Risk; Shipment. All delivery dates are approximate and Seller shall not be responsible for any damages resulting from any delay. Regardless of the manner of shipment, title to any products and risk of loss or damage shall pass to Buyer upon placement of the products with the shipment carrier at Seller's facility. Unless otherwise stated, Seller may exercise its judgment in choosing the carrier and means of delivery. No deferral of shipment at Buyers' request beyond the respective dates indicated will be made except on terms that will indemnify, defend and hold Seller harmless against all loss and additional expense. Buyer shall be responsible for any additional shipping charges incurred by Seller due to Buyer's acts or omissions.

4. Warranty. Seller warrants that the Products sold hereunder shall be free from defects in material or workmanship for a period of eighteen months from the date of delivery to Buyer. The prices charged for Seller's products are based upon the exclusive limited warranty stated above, and upon the following disclaimer: **DISCLAIMER OF WARRANTY: THIS WARRANTY COMPRISES THE SOLE AND ENTIRE WARRANTY PERTAINING TO PRODUCTS PROVIDED HEREUNDER. SELLER DISCLAIMS ALL OTHER WARRANTIES, EXPRESS AND IMPLIED, INCLUDING DESIGN, MERCHANTABILITY AND FITNESS FOR A PARTICULAR PURPOSE.**

5. Claims; Commencement of Actions. Buyer shall promptly inspect all Products upon delivery. No claims for shortages will be allowed unless reported to the Seller within 10 days of delivery. No other claims against Seller will be allowed unless asserted in writing within 30 days after delivery. Buyer shall notify Seller of any alleged breach of warranty within 30 days after the date the defect is or should have been discovered by Buyer. Any action based upon breach of this agreement or upon any other claim arising out of this sale (other than an action by Seller for an amount due on any invoice) must be commenced within 12 months from the date of the breach without regard to the date breach is discovered.

6. LIMITATION OF LIABILITY. UPON NOTIFICATION, SELLER WILL, AT ITS OPTION, REPAIR OR REPLACE A DEFECTIVE PRODUCT, OR REFUND THE PURCHASE PRICE. **IN NO EVENT SHALL SELLER BE LIABLE TO BUYER FOR ANY SPECIAL, INDIRECT, INCIDENTAL OR CONSEQUENTIAL DAMAGES ARISING OUT OF, OR AS THE RESULT OF, THE SALE, DELIVERY, NON-DELIVERY, SERVICING, USE OR LOSS OF USE OF THE PRODUCTS OR ANY PART THEREOF, OR FOR ANY CHARGES OR EXPENSES OF ANY NATURE INCURRED WITHOUT SELLER'S WRITTEN CONSENT, EVEN IF SELLER HAS BEEN NEGLIGENT, WHETHER IN CONTRACT, TORT OR OTHER LEGAL THEORY. IN NO EVENT SHALL SELLER'S LIABILITY UNDER ANY CLAIM MADE BY BUYER EXCEED THE PURCHASE PRICE OF THE PRODUCTS.**

7. User Responsibility. The user, through its own analysis and testing, is solely responsible for making the final selection of the system and Product and assuring that all performance, endurance, maintenance, safety and warning requirements of the application are met. The user must analyze all aspects of the application and follow applicable industry standards and Product information. If Seller provides Product or system options, the user is responsible for determining that such data and specifications are suitable and sufficient for all applications and reasonably foreseeable uses of the Products or systems.

8. Loss to Buyer's Property. Any designs, tools, patterns, materials, drawings, confidential information or equipment furnished by Buyer or any other items which become Buyer's property, will be considered obsolete and may be destroyed by Seller after two consecutive years have elapsed without Buyer ordering the items manufactured using such property. Seller shall not be responsible for any loss or damage to such property while it is in Seller's possession or control.

9. Special Tooling. A tooling charge may be imposed for any special tooling, including without limitation, dies, fixtures, molds and patterns, acquired to manufacture Products. Such special tooling shall be and remain Seller's property notwithstanding payment of any charges by Buyer. In no event will Buyer acquire any interest in apparatus belonging to Seller which is utilized in the manufacture of the Products, even if such apparatus has been specially converted or adapted for such manufacture and notwithstanding any charges paid by Buyer. Unless otherwise agreed, Seller shall have the right to alter, discard or otherwise dispose of any special tooling or other property in its sole discretion at any time.

10. Buyer's Obligation; Rights of Seller. To secure payment of all sums due or otherwise, Seller shall retain a security interest in the goods delivered and this agreement shall be deemed a Security Agreement under the Uniform Commercial Code. Buyer authorizes Seller as its attorney to execute and file on Buyer's behalf all documents Seller deems necessary to perfect its security interest.

11. Improper use and Indemnity. Buyer shall indemnify, defend, and hold Seller harmless from any claim, liability, damages, lawsuits, and costs (including attorney fees), whether for personal injury, property damage, patent, trademark or copyright

infringement or any other claim, brought by or incurred by Buyer, Buyer's employees, or any other person, arising out of: (a) improper selection, improper application or other misuse of Products purchased by Buyer from Seller; (b) any act or omission, negligent or otherwise, of Buyer; (c) Seller's use of patterns, plans, drawings, or specifications furnished by Buyer to manufacture Product; or (d) Buyer's failure to comply with these terms and conditions. Seller shall not indemnify Buyer under any circumstance except as otherwise provided.

12. Cancellations and Changes. Orders shall not be subject to cancellation or change by Buyer for any reason, except with Seller's written consent and upon terms that will indemnify, defend and hold Seller harmless against all direct, incidental and consequential loss or damage. Seller may change product features, specifications, designs and availability with notice to Buyer.

13. Limitation on Assignment. Buyer may not assign its rights or obligations under this agreement without the prior written consent of Seller.

14. Force Majeure. Seller does not assume the risk and shall not be liable for delay or failure to perform any of Seller's obligations by reason of circumstances beyond the reasonable control of Seller (hereinafter "Events of Force Majeure"). Events of Force Majeure shall include without limitation: accidents, strikes or labor disputes, acts of any government or government agency, acts of nature, delays or failures in delivery from carriers or suppliers, shortages of materials, or any other cause beyond Seller's reasonable control.

15. Waiver and Severability. Failure to enforce any provision of this agreement will not waive that provision nor will any such failure prejudice Seller's right to enforce that provision in the future. Invalidation of any provision of this agreement by legislation or other rule of law shall not invalidate any other provision herein. The remaining provisions of this agreement will remain in full force and effect.

16. Termination. Seller may terminate this agreement for any reason and at any time by giving Buyer thirty (30) days written notice of termination. Seller may immediately terminate this agreement, in writing, if Buyer: (a) commits a breach of any provision of this agreement (b) appointments a trustee, receiver or custodian for all or any part of Buyer's property (c) files a petition for relief in bankruptcy on its own behalf, or by a third party (d) makes an assignment for the benefit of creditors, or (e) dissolves or liquidates all or a majority of its assets.

17. Governing Law. This agreement and the sale and delivery of all Products hereunder shall be deemed to have taken place in and shall be governed and construed in accordance with the laws of the State of Ohio, as applicable to contracts executed and wholly performed therein and without regard to conflicts of laws principles. Buyer irrevocably agrees and consents to the exclusive jurisdiction and venue of the courts of Cuyahoga County, Ohio with respect to any dispute, controversy or claim arising out of or relating to this agreement.

18. Indemnity for Infringement of Intellectual Property Rights. Seller shall have no liability for infringement of any patents, trademarks, copyrights, trade dress, trade secrets or similar rights except as provided in this Section. Seller will defend and indemnify Buyer against allegations of infringement of U.S. patents, U.S. trademarks, copyrights, trade dress and trade secrets ("Intellectual Property Rights"). Seller will defend at its expense and will pay the cost of any settlement or damages awarded in an action brought against Buyer based on an allegation that a Product sold pursuant to this Agreement infringes the Intellectual Property Rights of a third party. Seller's obligation to defend and indemnify Buyer is contingent on Buyer notifying Seller within ten (10) days after Buyer becomes aware of such allegations of infringement, and Seller having sole control over the defense of any allegations or actions including all negotiations for settlement or compromise. If a Product is subject to a claim that it infringes the Intellectual Property Rights of a third party, Seller may, at its sole expense and option, procure for Buyer the right to continue using the Product, replace or modify the Product so as to make it noninfringing, or offer to accept return of the Product and return the purchase price less a reasonable allowance for depreciation. Notwithstanding the foregoing, Seller shall have no liability for claims of infringement based on information provided by Buyer, or directed to Products delivered hereunder for which the designs are specified in whole or part by Buyer, or infringements resulting from the modification, combination or use in a system of any Product sold hereunder. The foregoing provisions of this Section shall constitute Seller's sole and exclusive liability and Buyer's sole and exclusive remedy for infringement of Intellectual Property Rights.

19. Entire Agreement. This agreement contains the entire agreement between the Buyer and Seller and constitutes the final, complete and exclusive expression of the terms of sale. All prior or contemporaneous written or oral agreements or negotiations with respect to the subject matter are herein merged.

20. Compliance with Law, U. K. Bribery Act and U.S. Foreign Corrupt Practices Act. Buyer agrees to comply with all applicable laws and regulations, including both those of the United Kingdom and the United States of America, and of the country or countries of the Territory in which Buyer may operate, including without limitation the U. K. Bribery Act, the U.S. Foreign Corrupt Practices Act ("FCPA") and the U.S. Anti-Kickback Act (the "Anti-Kickback Act"), and agrees to indemnify and hold harmless Seller from the consequences of any violation of such provisions by Buyer, its employees or agents. Buyer acknowledges that they are familiar with the provisions of the U. K. Bribery Act, the FCPA and the Anti-Kickback Act, and certifies that Buyer will adhere to the requirements thereof. In particular, Buyer represents and agrees that Buyer shall not make any payment or give anything of value, directly or indirectly to any governmental official, any foreign political party or official thereof, any candidate for foreign political office, or any commercial entity or person, for the purpose of influencing such person to purchase products or otherwise benefit the business of Seller.



Parker's Motion & Control Technologies

At Parker, we're guided by a relentless drive to help our customers become more productive and achieve higher levels of profitability by engineering the best systems for their requirements. It means looking at customer applications from many angles to find new ways to create value. Whatever the motion and control technology need, Parker has the experience, breadth of product and global reach to consistently deliver. No company knows more about motion and control technology than Parker. For further info call 1 800 C-Parker (1 800 272 7537)



Aerospace Key Markets

- Aftermarket services
- Commercial transports
- Engines
- General & business aviation
- Helicopters
- Launch vehicles
- Military aircraft
- Missiles
- Power generation
- Regional transports
- Unmanned aerial vehicles

Key Products

- Control systems & actuation products
- Engine systems & components
- Fluid conveyance systems & components
- Fluid metering, delivery & atomization devices
- Fuel systems & components
- Fuel tank inerting systems
- Hydraulic systems & components
- Thermal management
- Wheels & brakes



Climate Control Key Markets

- Agriculture
- Air conditioning
- Construction Machinery
- Food & beverage
- Industrial machinery
- Life sciences
- Oil & gas
- Precision cooling
- Process
- Refrigeration
- Transportation

Key Products

- Accumulators
- Advanced actuators
- CO₂ controls
- Electronic controllers
- Filter driers
- Hand shut-off valves
- Heat exchangers
- Hose & fittings
- Pressure regulating valves
- Refrigerant distributors
- Safety relief valves
- Smart pumps
- Solenoid valves
- Thermostatic expansion valves



Electromechanical Key Markets

- Aerospace
- Factory automation
- Life science & medical
- Machine tools
- Packaging machinery
- Paper machinery
- Plastics machinery & converting
- Primary metals
- Semiconductor & electronics
- Textile
- Wire & cable

Key Products

- AC/DC drives & systems
- Electric actuators, gantry robots & slides
- Electrohydraulic actuation systems
- Electromechanical actuation systems
- Human machine interface
- Linear motors
- Stepper motors, servo motors, drives & controls
- Structural extrusions



Filtration Key Markets

- Aerospace
- Food & beverage
- Industrial plant & equipment
- Life sciences
- Marine
- Mobile equipment
- Oil & gas
- Power generation & renewable energy
- Process
- Transportation
- Water Purification

Key Products

- Analytical gas generators
- Compressed air filters & dryers
- Engine air, coolant, fuel & oil filtration systems
- Fluid condition monitoring systems
- Hydraulic & lubrication filters
- Hydrogen, nitrogen & zero air generators
- Instrumentation filters
- Membrane & fiber filters
- Microfiltration
- Sterile air filtration
- Water desalination & purification filters & systems



Fluid & Gas Handling

Key Markets

- Aerial lift
- Agriculture
- Bulk chemical handling
- Construction machinery
- Food & beverage
- Fuel & gas delivery
- Industrial machinery
- Life sciences
- Marine
- Mining
- Mobile
- Oil & gas
- Renewable energy
- Transportation

Key Products

- Check valves
- Connectors for low pressure fluid conveyance
- Deep sea umbilicals
- Diagnostic equipment
- Hose couplings
- Industrial hose
- Mooring systems & power cables
- PTFE hose & tubing
- Quick couplings
- Rubber & thermoplastic hose
- Tube fittings & adapters
- Tubing & plastic fittings



Hydraulics

Key Markets

- Aerial lift
- Agriculture
- Alternative energy
- Construction machinery
- Forestry
- Industrial machinery
- Machine tools
- Marine
- Material handling
- Mining
- Oil & gas
- Power generation
- Refuse vehicles
- Renewable energy
- Truck hydraulics
- Turf equipment

Key Products

- Accumulators
- Cartridge valves
- Electrohydraulic actuators
- Human machine interfaces
- Hybrid drives
- Hydraulic cylinders
- Hydraulic motors & pumps
- Hydraulic systems
- Hydraulic valves & controls
- Hydrostatic steering
- Integrated hydraulic circuits
- Power take-offs
- Power units
- Rotary actuators
- Sensors



Pneumatics

Key Markets

- Aerospace
- Conveyor & material handling
- Factory automation
- Life science & medical
- Machine tools
- Packaging machinery
- Transportation & automotive

Key Products

- Air preparation
- Brass fittings & valves
- Manifolds
- Pneumatic accessories
- Pneumatic actuators & grippers
- Pneumatic valves & controls
- Quick disconnects
- Rotary actuators
- Rubber & thermoplastic hose & couplings
- Structural extrusions
- Thermoplastic tubing & fittings
- Vacuum generators, cups & sensors



Process Control

Key Markets

- Alternative fuels
- Biopharmaceuticals
- Chemical & refining
- Food & beverage
- Marine & shipbuilding
- Medical & dental
- Microelectronics
- Nuclear Power
- Offshore oil exploration
- Oil & gas
- Pharmaceuticals
- Power generation
- Pulp & paper
- Steel
- Water/wastewater

Key Products

- Analytical Instruments
- Analytical sample conditioning products & systems
- Chemical injection fittings & valves
- Fluoropolymer chemical delivery fittings, valves & pumps
- High purity gas delivery fittings, valves, regulators & digital flow controllers
- Industrial mass flow meters/ controllers
- Permanent no-weld tube fittings
- Precision industrial regulators & flow controllers
- Process control double block & bleeds
- Process control fittings, valves, regulators & manifold valves



Sealing & Shielding

Key Markets

- Aerospace
- Chemical processing
- Consumer
- Fluid power
- General industrial
- Information technology
- Life sciences
- Microelectronics
- Military
- Oil & gas
- Power generation
- Renewable energy
- Telecommunications
- Transportation

Key Products

- Dynamic seals
- Elastomeric o-rings
- Electro-medical instrument design & assembly
- EMI shielding
- Extruded & precision-cut, fabricated elastomeric seals
- High temperature metal seals
- Homogeneous & inserted elastomeric shapes
- Medical device fabrication & assembly
- Metal & plastic retained composite seals
- Shielded optical windows
- Silicone tubing & extrusions
- Thermal management
- Vibration dampening

ENGINEERING YOUR SUCCESS.



*Visit us on the web
parker.com/cylinder*

05/15 / Catalog HY08-1114-6/NA



Parker Hannifin Corporation
Industrial Cylinder Division
500 South Wolf Road
Des Plaines, IL 60016 USA
phone (847) 298-2400
fax (800) 892-1008
www.parker.com/cylinder

Parker Hannifin Corporation
Motion and Control Division
160 Chisholm Drive
Milton, ON Canada L9T 3G9
direct (905) 693-3000
fax (905) 876-1958
www.parker.com



aerospace
climate control
electromechanical
filtration
fluid & gas handling
hydraulics
pneumatics
process control
sealing & shielding



Medium Duty Hydraulic Cylinders

Series 3L



ENGINEERING YOUR SUCCESS.

In line with our policy of continuing product improvement, specifications and information contained in this catalog are subject to change.

Copyright ©2009, 2010, 2011 by Parker Hannifin Corporation.
All rights reserved.

PRINTED IN THE U.S.A.

 **WARNING**

FAILURE OR IMPROPER SELECTION OR IMPROPER USE OF THE PRODUCTS AND/OR SYSTEMS DESCRIBED HEREIN OR RELATED ITEMS CAN CAUSE DEATH, PERSONAL INJURY AND PROPERTY DAMAGE.

This document and other information from the Parker Hannifin Corporation, its subsidiaries and authorized distributors provide product and/or system options for further investigation by users having expertise. It is important that you analyze all aspects of your application, including consequences of any failure and review the information concerning the product or system in the current product catalog. Due to the variety of operating conditions and applications for these products or systems, the user, through its own analysis and testing, is solely responsible for making the final selection of the products and systems and assuring that all performance, safety and warning requirements of the application are met.

The products described herein, including without limitation, product features, specifications, designs, availability and pricing, are subject to change by Parker Hannifin Corporation and its subsidiaries at any time without notice.

Offer of Sale

The items described in this document are hereby offered for sale by Parker Hannifin Corporation, its subsidiaries or its authorized distributors. This offer and its acceptance are governed by provisions stated on a separate page of the document entitled 'Offer of Sale'.





Series CHE

- 20 through 100mm Bore Sizes
- Stroke Lengths to 150mm
- Operating Pressure to 140 bar
- 4 Different Rod Ends Available

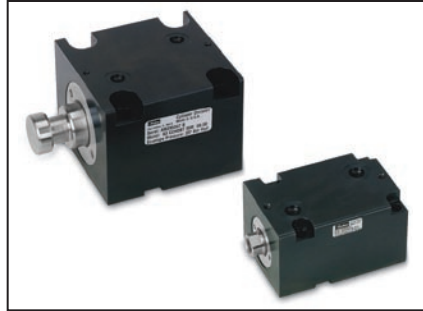

Series CHD

- 20 through 80mm Bore Sizes
- Stroke Lengths to 100mm
- Operating Pressure to 207 bar
- 4 Different Rod Ends Available

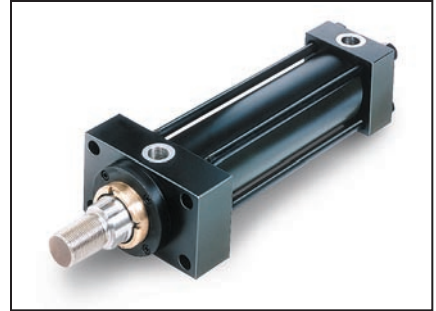

Series HMI

- Bore Sizes 25 through 200mm
- ISO 6020/2 Interchangeable
- 12 Standard Mounting Styles
- 210 Bar Hydraulic Pressure

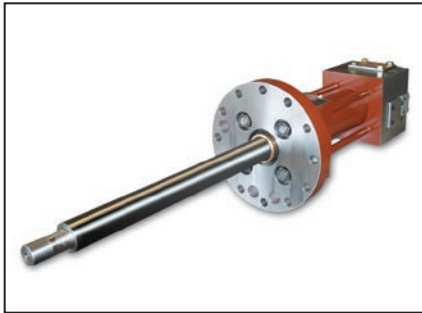

Custom Cylinder

- Bore Sizes to 42.00"
- Stroke Lengths to 70'
- Operating Pressure to 10,000 psi
- Third Party Agency Approval



Series 2H

- Bore Sizes 1.50" through 6.00"
- 3000 psi Hydraulic Service
- 16 NFPA Mounting Styles
- Specials to Order



3LX

- Bore Sizes 2.00" through 8.00"
- LDT or LRT Feedback
- Integrated Manifolds Available
- Protective Covers Available

Parker Hannifin's Industrial Cylinder Division offers products that are designed to meet and exceed the most demanding application requirements. Our extensive product line offers OEM's and End Users hydraulic and pneumatic cylinder solutions that provide value through reduced maintenance, increased productivity, and long service life. Parker Industrial Cylinder's wide breadth of product encompasses NFPA, ISO, and Custom designed products in a multitude of configurations and sizes.

Series 3L/2H Magnetic Piston

Position Sensing Technology
for Hydraulic Cylinders

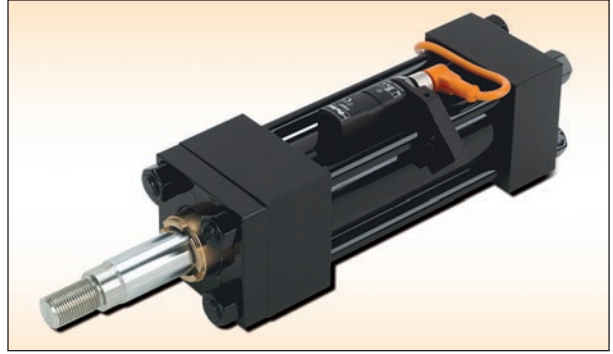

Series 3L Cylinder – with Hi-Load magnetic piston

Durable polyurethane bi-directional seal – for positive sealing with no by-pass and long life.

WearGard™ wear band – improves resistance to bearing loads and provides support for magnet.

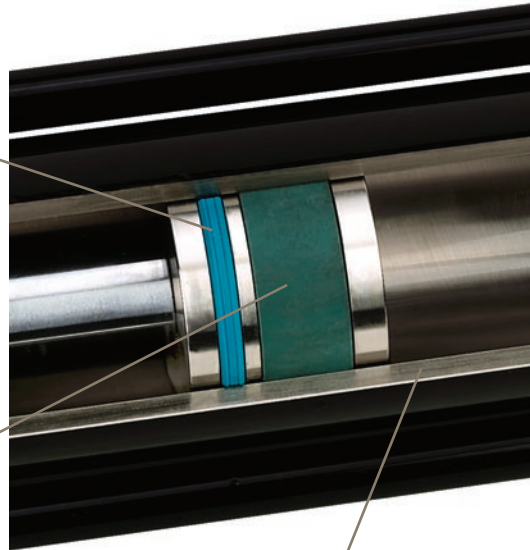

Cylinder Body – Standard steel material for ALS Switch or 316 stainless steel for conventional solid state or reed switches. Aluminum material available for global switches at reduced operating pressure rating. See facing page for details.

Customer Value Proposition:

Parker's magnetic sensing option for hydraulic steel/tie rod construction cylinders provides OEM's and end users the ability to sense piston position in an economical and reliable fashion through the use of innovative magnet and switching technology. The magnetic piston option offers all users the choice to eliminate added cylinder

machining costs, stand alone external brackets/hardware, and reduced system set-up time. By incorporating sensing capability into steel/tie rod style cylinders, the need to fabricate, install, wire, and adjust stand alone proximity switches can be eliminated – thus providing a clean and more efficient position monitoring system.

Product Features:

- Available for Series 3L, 2H and 2A cylinders
- Available for Series 2H in 1.50" - 6.00" bores. Series 3L and 2A in 1.00" - 4.00" bores.
- Available on 15 different mounting styles
- Adjustability over the entire working stroke length
- Multiple switches can be used per cylinder
- Non intrusive design eliminates potential leakage

Magnetic Switch Choices

Making The Best Choice
Parker's ALS Switch and Global Switch are designed to offer customers an alternative means of sensing hydraulic cylinder piston position. Depending on the application, and the budget, one switch type may be better suited to fulfill customer needs than the other. Some of the important things to consider when analyzing what switch to choose are listed at right.

- Can be positioned at any location along the cylinder to indicate end-of-stroke or mid-stroke locations.
- Allow multiple switches to be installed with numbers only restricted by available tie rod mounting space.
- Available for Series 2H in 1.50" - 6.00" bores. Series 3L and 2A in 1.00" - 4.00" bores.

Maximum Pressure Rating for 3L Cylinder with Aluminum Tube

Bore Ø	Pressure Rating (psi) ¹
1.00	1900
1.50	1500
2.00	1100
2.50	950 ²
3.25	750
4.00	600

¹ When using Series 3L cylinders with aluminum bodies, do not introduce any shock or high inertia loading conditions. Pressure spikes must be avoided.

² Maximum pressure for aluminum tube in 2.50" bore with code 7 rod is 700 psi.

Technology Comparison

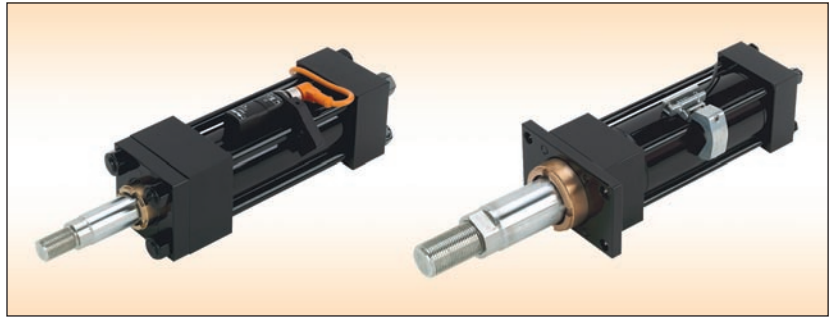

ALS Switch

- Compatible with standard steel tube
- +10 to +30 VDC power requirement
- PNP/NPN wired NO or NC
- Solid state construction
- 2 LED indicators (power & target)
- 12mm connector
- IP 67 rated
- Temperature Range: -25°C to +85°C
- Short circuit protection

Global Switch

- Uses 316 stainless steel tube
- +10 to +30 VDC, +10 to +120 VAC power requirement
- PNP/NPN, Reed
- Solid state construction
- 1 power LED indicator
- 12mm or 8mm connector, flying leads
- IP 68 rated
- Temperature Range: -25°C to +75°C
- Short circuit protection

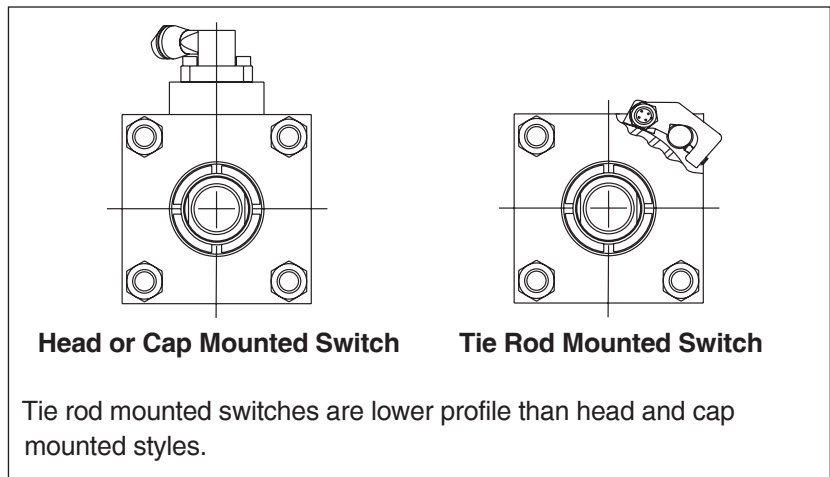

Head or Cap Mounted Switch

Tie Rod Mounted Switch

Tie rod mounted switches are lower profile than head and cap mounted styles.

Extreme High Temperature Seal Option – Up to 400° F

For Series 3L, 2H/2HD, 3H/3HD and 2A Cylinders



Customer Value Proposition:

Parker's Extreme High Temperature Seal Option will provide OEM's and End Users an increase in machine productivity through improved resistance to heat degradation as compared to typical fluorocarbon seals. With a maximum continuous temperature rating of 400° F, the Extreme High Temperature Seal Option will allow longer service life in applications that require the use of alternative fluid types and demand superior heat resistance. Parker's innovative seal design utilizes PTFE materials that are constantly energized to provide excellent seal performance and long life. Customers utilizing this design will realize a reduction in machine downtime due to seal failure associated with high temperature exposure.

Product Features:

- Operating temperature to 400° F
- Broad range of fluid compatibility
- Available bore sizes: 1.50" through 8.00"; rod diameters 1.000" through 5.500"
- Stainless steel spring loads both dynamic and static piston seal lips
- No additional delivery time

Wiperseal – Unique profile of bronze filled PTFE wiperseal provides performance of a third rod seal while scraping contaminants from the piston rod as it retracts. A fluorocarbon energizer ensures constant contact of wiperseal to the piston rod.

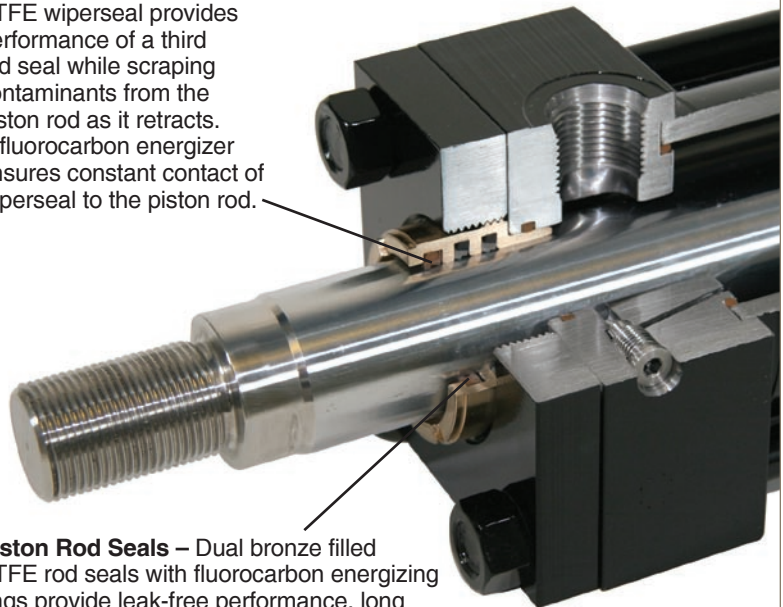

Piston Rod Seals – Dual bronze filled PTFE rod seals with fluorocarbon energizing rings provide leak-free performance, long life, and heat resistance to 400° F.

Cylinders for High Temperature Applications

When your customer demands a long life cylinder with outstanding heat resistance, look no further than Parker's new Extreme High Temperature Seal option.

Filled PTFE piston seals, rod seals, and wiperseal provide maximum resistance to extreme heat (up to 400° F) with excellent service life.

PTFE seals are mechanically energized to maintain uniform contact to dynamic sealing surfaces for positive leak-free performance across the entire operating pressure range. Static seals are fluorocarbon for a complete heat resistant assembly.

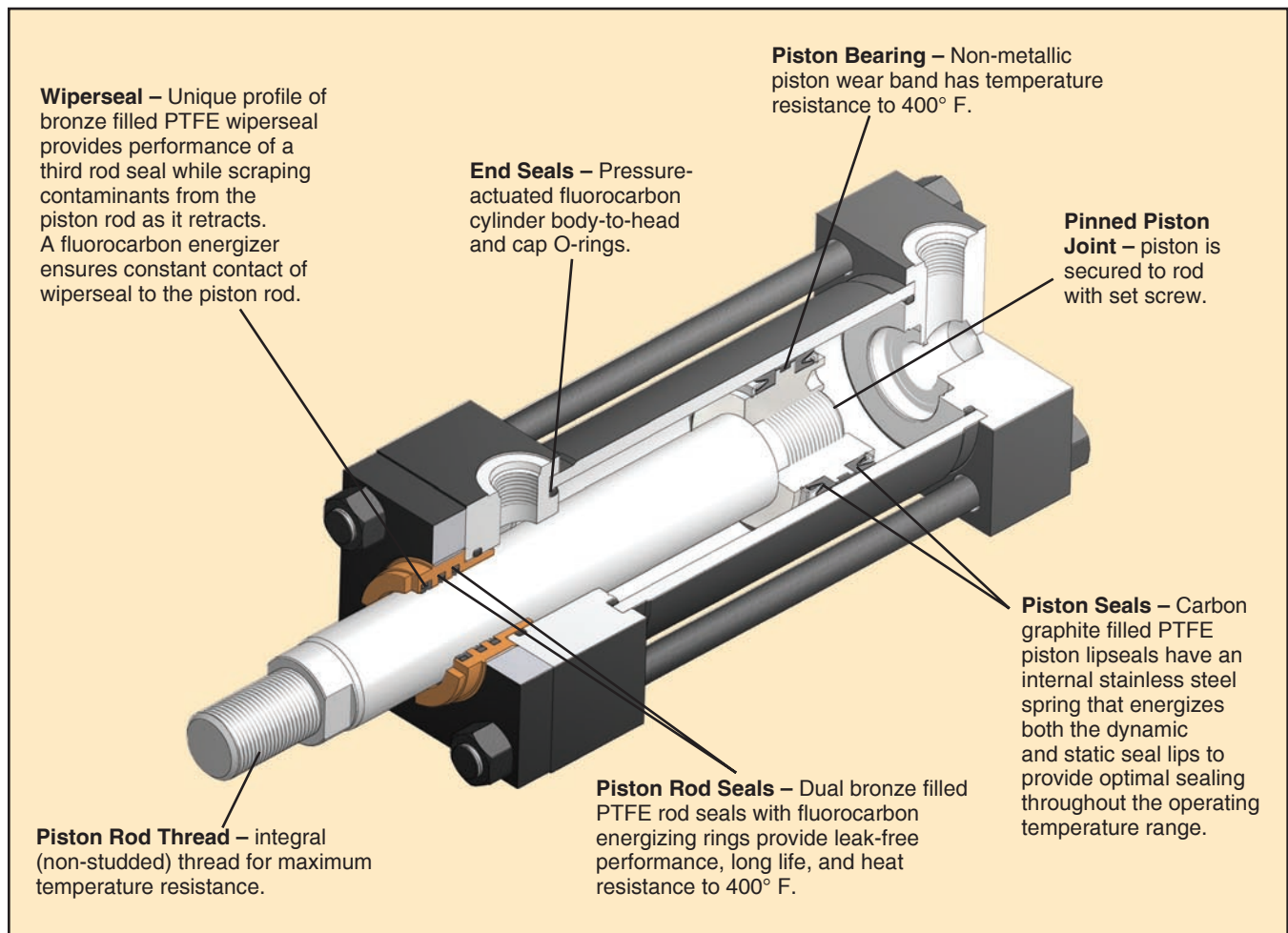



With annual sales exceeding \$10 billion, Parker Hannifin is the world's leading diversified manufacturer of motion and control technologies and systems, providing precision-engineered solutions for a wide variety of mobile, industrial and aerospace markets. The company employs approximately 52,000 people in 48 countries around the world. Parker has increased its annual dividends paid to shareholders for 53 consecutive years, among the top five longest-running dividend-increase records in the S&P 500 index. For more information, visit the company's web site at <http://www.parker.com>, or its investor information site at <http://www.phstock.com>.

Parker is Engineering

Fluid Power and application expertise provide customers the opportunity to use us as an extension of their design teams.

From new system design to improvements required for existing applications, Parker offers unparalleled engineering expertise. We'll help you develop cost saving, high performance solutions that provide value through increased productivity, improved machine efficiency, and reduced downtime.

Our design engineers utilize the highest quality materials and cutting edge manufacturing processes available to push the envelope for performance, value and reliability.

Parker components and systems are made to last. We offer complete system solutions for the following industries:

- Plastics
- Metal Forming
- Steel
- Press
- Off Shore Oil
- Forestry
- Mining
- Entertainment
- Flight Simulation
- Fatigue Testing
- Automation

Worldwide Supplier to Industrial Markets

Parker Hannifin is the world's leading supplier of motion and control technologies that include; motion control products, systems, and complete engineered solutions for industrial markets. Parker's broad and extensive breadth of product

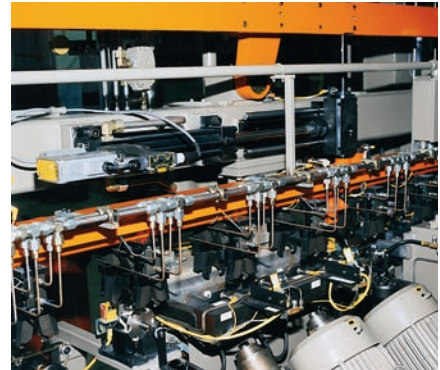

offer single source capability with limitless possibilities. Our industrial product solutions range from state of the art stand-alone components to complete engineered systems that are designed to provide value and efficiency to all of our customers. Each component and system is backed up with superior application expertise and technical support that you would expect from Parker Hannifin.



Table of Contents

<i>Description</i>	<i>Page</i>	<i>Section</i>
Series 3L Medium Duty Hydraulic Cylinders	1	A
Cylinder Accessories and Replacement Parts	41	B
Custom Modifications	53	C
Engineering Data	61	D

Manufacturing Locations



Atlanta, GA



Enfield, CT



Corona, CA



Plymouth, MI



Goodland, IN

California
221 Helicopter Circle
Corona, CA 92880
Tel.: (951) 280-3800
Fax: (951) 280-3808
Fax: (800) 869-9886

Connecticut
80 Shaker Road
Enfield, CT 06082
Tel.: (860) 749-2215
Fax: (800) 323-0105

Georgia
1300 Six Flags Road
Lithia Springs, GA 30122
Tel.: (770) 819-3400
Fax: (800) 437-3498

Indiana
Goodland Plant
715 South Iroquois Street
Goodland, IN 47948
Tel.: (219) 297-3182
Fax: (800) 328-8120

Michigan
900 Plymouth Road
Plymouth, MI 48170
Tel.: (734) 455-1700
Fax: (734) 455-1007

Oregon
29289 Airport Road
Eugene, OR 97402-0079
Tel.: (541) 689-9111
Fax: (541) 688-6771
Fax: (800) 624-7996



Eugene, OR

Table of Contents

Series 3L

	1.00" - 5.00" Bore	6.00" & 8.00" Bore
Performance	2	2
Specifications and Mounting Styles	3	3
Features and Benefits	4	4
Application Check List	6	6
Mounting Styles & Tips for Applying	7	7
3L Cylinder Model Code & How To Order	8	8
Rod End Styles and Dimensions	10	26
TB, TC, TD Mount Dimensions	12	28
J Mount Dimensions	13	13 (6.00" Bore only)
JB Mount Dimensions	14	29
JJ Mount Dimensions	15	15 (6.00" Bore only)
H Mount Dimensions	16	16 (6.00" Bore only)
HB Mount Dimensions	17	30
C Mount Dimensions	18	31
F Mount Dimensions	19	32
BB Mount Dimensions	20	33
D Mount Dimensions	21	34
DB Mount Dimensions	22	35
DD Mount Dimensions	23	36
1.00" Bore Mounting Information	24	NA
SB Mount Dimensions	25	37
Double Rod End Models	38	38

A

The medium-duty hydraulic cylinder with a proven record of performance.

Parker Series 3L cylinders provide value through proven reliability, efficient performance, and quality that you expect from every Parker Industrial Cylinder Division product line. Each Series 3L cylinder incorporates design features one would not expect to see in a 1,000 psi nominally rated cylinder. These features include the “Jewel” rod gland, adjustable floating cushions, case hardened piston rod assemblies, and high strength tie rods with

rolled threads instead of cut threads. Each and every Parker cylinder is hand built and tested before it leaves our facility to ensure leak and trouble free operation. At Parker, we place a high emphasis on quality and design to ensure value and productivity for all of our customers. Make the Parker Series 3L your choice for medium duty hydraulic cylinders today and for the future.



Standard Specifications

- Medium Duty Service – ANSI/(NFPA) T3.6.7R2 - 1996 Specifications and Mounting Dimension Standards
- Standard Construction – Square Head – Tie Rod Design
- Nominal Pressure – 1000 psi Dependent on Bore Size¹
- Standard Fluid – Hydraulic Oil
- Standard Temperature – -10°F to +165°F²
- Bore Sizes – 1.00" through 8.00"

Note: Series 3L Hydraulic Cylinders fully meet ANSI/(NFPA) T3.6.7R2 - 1996 Specifications and Mounting Dimensions for Square Head Industrial Fluid Power Cylinders.

In line with our policy of continuing product improvement, specifications in this catalog are subject to change.

- Piston Rod Diameter – 0.500" through 5.500"
- Mounting Styles – 15 standard styles at various application ratings
- Strokes – Available in any practical stroke length
- Cushions – Optional at either end or both ends of stroke. "Float Check" at cap end.
- Rod Ends – Four Standard Choices – Specials to Order

¹ See Section D to determine maximum pressure rating by bore and rod combination.

² See Section D – Fluids/Temperature/Pressure Ratings for information regarding higher temperature service.



Available Mounting Styles

<p>Basic Style T</p> <p>(NFPA MX0)</p>	<p>Tie Rods Extended Head End Style TB</p> <p>(NFPA MX3)</p>	<p>Tie Rods Extended Cap End Style TC</p> <p>(NFPA MX2)</p>	<p>Tie Rods Extended Both Ends Style TD</p> <p>(NFPA MX1)</p>
<p>Head Rectangular Flange Style J</p> <p>(NFPA MF1)</p>	<p>Head Square Flange Style JB</p> <p>(NFPA MF5)</p>	<p>Head Rectangular Style JJ³</p>	<p>Cap Rectangular Flange Style H</p> <p>(NFPA MF2)</p>
<p>Cap Square Flange Style HB</p> <p>(NFPA MF6)</p>	<p>Side Lug Style C</p> <p>(NFPA MS2)</p>	<p>Side Tapped Style F</p> <p>(NFPA MS4)</p>	<p>Head Trunnion Style D</p> <p>(NFPA MT1)</p>
<p>Cap Trunnion Style DB</p> <p>(NFPA MT2)</p>	<p>Intermediate Fixed Trunnion Style DD</p> <p>(NFPA MT4)</p>	<p>Cap Fixed Clevis Style BB</p> <p>(NFPA MP1)</p>	<p>Spherical Bearing Style SB</p>
<p>Double Rod Cylinders</p>		<p>Style KTB Shown</p>	

³Parker Style JJ mount for the Series 3L is a non-NFPA mount.

Most of the above illustrated mounting styles are available in double rod cylinders.

The inside story on why Series 3L is your best choice in medium duty hydraulic cylinders

Primary Seal – TS-2000 Rod Seal is a proven leakproof design – completely self-compensating and self-relieving to withstand variations and conform to mechanical deflection that may occur.

Secondary Seal – Double-Service Wiperseal™ wipes clean any oil film adhering to the rod on the extend stroke and cleans the rod on the return stroke.

Piston Rod Stud – Furnished on 2.000" diameter rods and smaller when standard style #4 rod end threads are required. Studs have rolled threads and are made from high strength steel. Anaerobic adhesive is used to permanently lock the stud to the piston rod.

Piston Rod – Medium carbon steel, induction case-hardened, hard chrome-plated and polished to 10 RMS finish. Piston rods are made from 85,000 to 100,000 psi minimum yield material in .500" through 4.000" diameters. Larger diameters vary between 57,000 and 90,000 psi minimum material, depending on rod diameter. The piston thread equals the catalog style #4 rod end thread for each rod diameter to assure proper piston-to-rod thread strength. Two wrench flats are provided for rod end attachment.

Alloy Steel Tie Rod Nuts

Steel Head – Bored and grooved to provide concentricity for mating parts.

End Seals – Pressure-actuated cylinder body-to-head and cap o-rings.

"Jewel" Rod Gland Assembly – Externally removable without cylinder disassembly. Long bearing surface is inboard of the seals, assuring positive lubrication from within the cylinder. An o-ring is used as a seal between gland and head, and also serves as a prevailing torque-type lock.

Align-A-Groove – A $\frac{3}{16}$ " wide surface machined at each end of the cylinder body. Makes precise mounting quick and easy.

The Cylinder Body – Heavy-wall steel tubing, honed to a micro finish bore.

Adjustable floating cushions

Cushions are optional and can be supplied at head end, cap end, or both ends without change in envelope or mounting dimensions. All Parker cushions are adjustable.

The Series 3L cylinder design incorporates the longest cushion sleeve and cushion spear that can be provided in the standard envelope without decreasing the rod bearing and piston bearing lengths.

- (1) When a cushion is specified at the head end:
 - a. A self-centering sleeve is furnished on the piston rod assembly.
 - b. A needle valve is provided that is flush with the side of the head when wide open. It may be identified by the fact that it is socket keyed. It is located on side number 2, in all mounting styles except D, DB and DD. In these styles it is located on side number 3.
 - c. On 3.25" bores and larger, a springless check valve is provided that is also flush with the side of the head and is mounted adjacent to the needle

valve except on certain bores of mounting style C where it is mounted opposite the needle valve. It may be identified by the fact that it is slotted.

- d. The check and needle valves are interchangeable in the head.
 - e. 1.00" - 2.50" bore 3L's utilize a slotted sleeve design in place of the check valve.
- (2) When a cushion is specified at the cap end:
 - a. A cushion spear is provided on the piston rod assembly.
 - b. A "float check" self-centering bushing is provided which incorporates a large flow check valve for fast "out-stroke" action.
 - c. A socket-keyed needle valve is provided that is flush with the side of the cap when wide open. It is located on side number 2 in all mounting styles except D, DB, and DD. In these styles it is located on side number 3.

One-Piece Nodular Iron Piston – The wide piston surface contacting cylinder bore reduces bearing loads. Anaerobic adhesive is used to permanently lock and seal the piston to the rod.

High Strength Tie Rods – Made from 100,000 psi minimum yield steel with rolled threads for added strength.

Steel Cap – Bored and grooved to provide concentricity for mating parts.

Ports – NPTF ports are standard.

Optional Ports

Ports – SAE “O” ring ports are optional at no extra charge. Oversize NPTF and SAE ports are available at extra charge.

Seals – Buna-N (Nitrile) seals are standard.

Fluorocarbon Seals – Optional at extra charge.

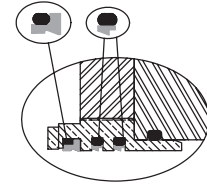

Optional High Temperature Gland – Dual filled PTFE rod seals and filled PTFE wiper seal are energized with fluorocarbon o-rings to maintain consistent contact with the piston rod. Excellent sealing performance produce dry rod on extend stroke with rod scraping to clean rod on retract. Combine with Spring Loaded PTFE Piston Seals for cylinder heat resistance to 400° F. See class 8 seal specification on Operating Fluids and Temperature Range page.

Lipseal™ Piston
 Zero leakage under static conditions. Seals are self-compensating to conform to variations in pressure, mechanical deflection, and wear. Back-up washers prevent extrusion.

Optional Spring Loaded PTFE Piston Seals

Filled PTFE piston Lipseals utilize an internal stainless steel spring to energize both the dynamic and static sealing lips to optimize seal performance throughout the operating temperature range. Non-metallic piston wear ring reduces possibility of damaging piston which can score expensive tubing. Combine with High Temperature Gland

for cylinder heat resistance to 400° F. See class 8 seal specification on Operating Fluids and Temperature Range page.

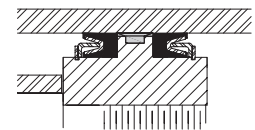

Cushion Length

Bore Ø	Rod Ø ¹	Rod Number	Cushion Length	
			Head ¹	Cap
1.00	0.500	1	0.88	0.75
	0.625	2	0.88	0.75
1.50	0.625	1	0.88	0.81
	1.000	2	0.88	0.81
2.00	0.625	1	0.88	0.81
	1.375	2	0.88	0.81
2.50	1.000	1	0.88	0.81
	1.750	2	0.88	0.81
3.25	1.000	1	1.13	1.00
	2.000	2	0.81	1.00
4.00	1.375	1	1.13	1.00
	2.500	2	0.81	1.00
5.00	1.750	1	1.13	1.00
	3.500	2	0.81	1.00
6.00	1.750	1	1.38	1.25
	4.000	2	1.06	1.25
8.00	2.000	1	1.06	1.25
	5.500	2	0.94	1.25

¹Head end cushions for rod diameters not listed have cushion lengths within the limits shown.

Adjustable Stepped Floating Cushions – Optional at extra charge. For faster cycle time and increased productivity – for maximum performance – economical and flexible for even the most demanding applications – reduces shock and machine noise – lower maintenance costs – can be supplied at head, cap or both ends.

Optional Adjustable Floating Stepped Cushions

Sleeve Design | Spear Design

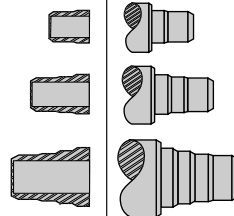

Application Checklist

The following checklist should be used to select the best possible cylinder for a given application. Additional information can be referenced in the following pages to help assist in this process. In the event that you have additional questions or concerns, or if more information is required, please contact your local Parker distributor or our customer service representatives for assistance.

- 1. Establish the system requirements**..... **Series 3L**
 - How heavy is the load to be moved?
 - What is the nominal operating pressure of the system?
 - How far does the load have to move?
 - What is the speed at which the load will move?
 - What is the fluid type and the temperature to which the cylinder will be exposed?

- 2. Mounting Style**..... Page 7
 - Determine the best mounting style for the application.

- 3. Cylinder Bore and Operating Pressure**..... Page 62
 - Review the theoretical push and pull force for a given bore size to determine.

- 4. Piston Rod**..... Page 71
 - Determine what rod size will be required to avoid buckling.
 - Determine if a single or double rod cylinder is required.
 - Determine the rod end style and rod end thread.
 - Will stop tubing be required?

- 5. Piston Seals** Page 5
 - Determine the best seal type for your application.
 - Select the proper seal type and configuration for the application.
 - Select the proper seal to assure fluid and temperature compatibility.

- 6. Cushioning**..... Page 74
 - Determine if cushions are required to safely stop the load.

- 7. Ports**..... Page 67
 - Select the best possible port size for a given speed requirement.
 - Select port position.

- 8. Piston rod and mounting accessories**..... Page 42
 - Determine how you will attach the cylinder to the load.

- 9. Optional accessories and modifications** Page 41

Mounting Styles & Tips for Applying Them

Extended Tie Rod Mountings – TB, TC and TD

Application:

- Straight line force transfer
- Compression loads (push)
– use TC or TD
- Tension loads (pull)
– use TB or TD

Advantages:

- Ease of mounting in tight spaces
- Force is transferred along the centerline of the cylinder

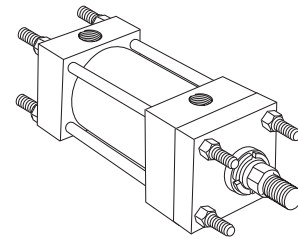

Flange Mountings – J, JB, JJ, H and HB

Application:

- Straight line force transfer
- Compression loads (push)
– use H or HB
- Tension loads (pull)
– use J, JB, or JJ

Advantages:

- Rigid base mounting due to large flange area
- Force is transferred along the centerline of the cylinder

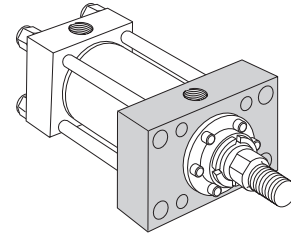

Side Tap Mounting – F / Side Lug Mounting – C

Application:

- Straight line force transfer
- Can be used in compression or tension loads
- Thrust key and secure mounting area are vital

Advantages:

- Ease of mounting

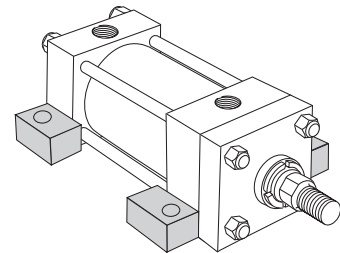

Pivot Mountings – BB and SB

Application:

- Curved or arc line force transfer
- Can be used in compression or tension loads
- Movement in a simple arc
– use BB mountings
- Movement in a compound arc
– use SB mountings

Advantages:

- Ease of mounting
- Design flexibility
- Self aligning (SB)

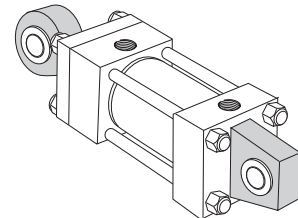

Trunnion Mountings – D, DB and DD

Application:

- Curved or arc line force transfer
- Can be used in compression or tension loads
- Compression loads – use DB or DD mountings
- Tension loads – use D or DD mountings

Advantages:

- Ease of mounting
- Design flexibility
- Self aligning

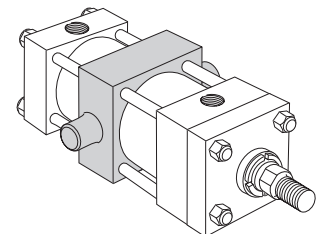

3L Model Code

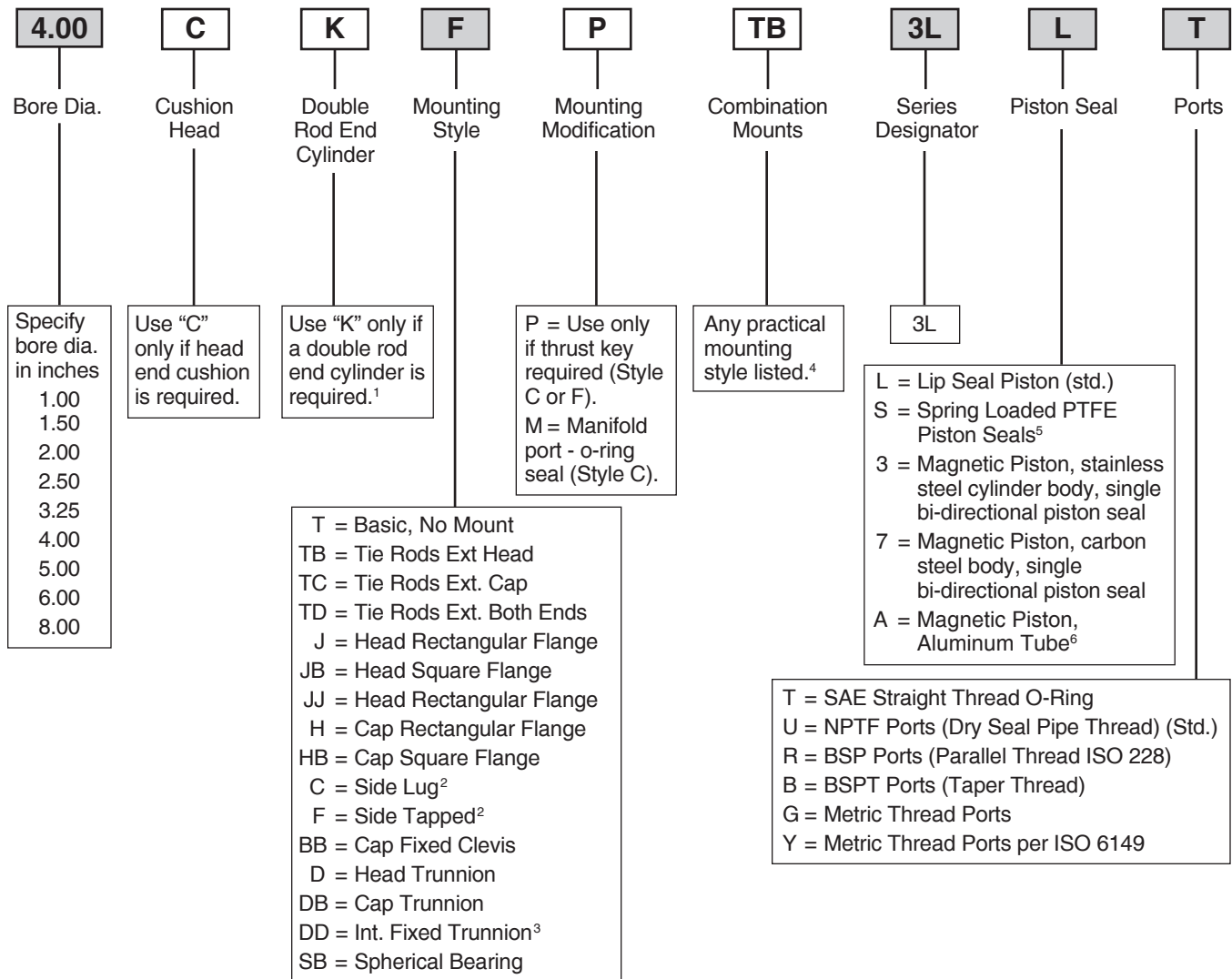

Shaded boxes identify required model number fields.

¹ Available mounting styles for K Type cylinders are located at the end of Section A. When ordering a double rod end cylinder, the piston rod number and piston rod end threads are to be specified for both rod ends.

The model number should be created as viewing the primary rod end on the left hand side.

Example: K Type Cylinder:
4.00CKTD3LT14A28AC10.000

² Mounting Styles C and F should have a minimum stroke length equal to or greater than their bore size.

³ Specify XI dimension.

⁴ In general, the model numbers as read left to right corresponding to the cylinder as viewed from left to right with the primary end at the left. The second or subsequent mountings are mountings called out as they appear in the assembly moving away from the rod end. Except when tie rod extension mountings are part of a combination, all combinations should have a "S" (Special) in the model code and a note in the body of the order clarifying the mounting arrangement. The "P", as used to define a thrust key is not considered to be a mounting. However it is located at the primary end.

⁵ Spring loaded PTFE piston seals are not available in 1.50", 2.00" and 2.50" bore with Code 2 rod.

⁶ See 3L pressure rating table on Introduction page III for aluminum tube option associated with magnetic piston.

How To Order

3L Model Code

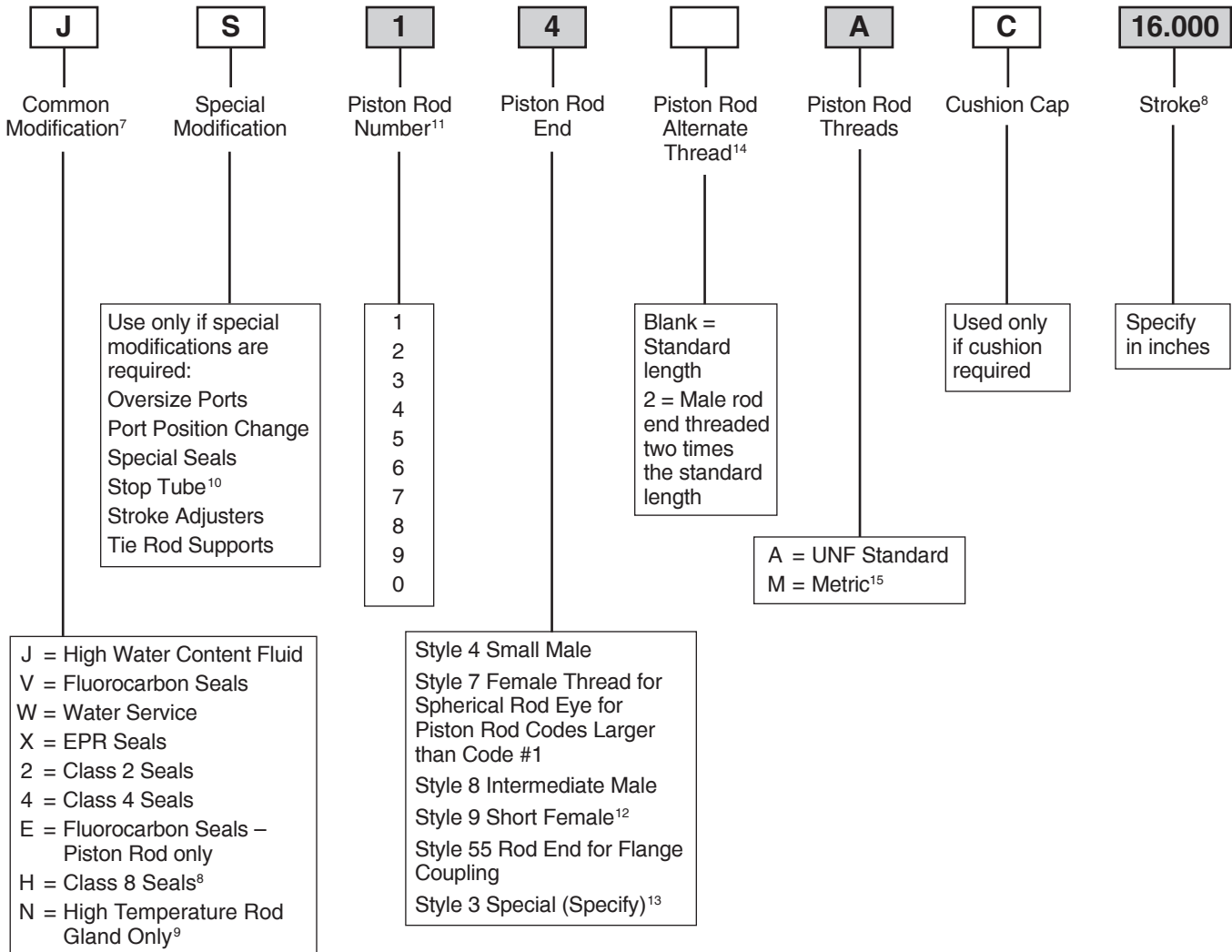

Shaded boxes identify required model number fields.

⁷ See common modifications Section C for additional options.

⁸ Cast iron piston ring seals will be supplied in 1.50", 2.00" and 2.50" bores with Code 2 rod when Class 8 seals are specified.

⁹ Energized PTFE rod seals & wiper seal. All other seals are fluorocarbon.

¹⁰ S = Stop Tube. Specify: stop tube length, net stroke and gross stroke. Gross stroke = stop tube length + net stroke. Gross stroke to be placed in the model number field.

Example:

2.000 inches long stop tube
+14.000 inches net stroke
16.000 inches gross stroke

¹¹ Refer to Rod buckling chart in Section D to assure rod number selected will not buckle under load.

¹² Style 9 stroke restrictions may apply. See Style 9 Minimum Stroke Table for details.

¹³ Provide dimensions for KK, A, W or WF. If otherwise special, furnish dimensioned sketch.

¹⁴ Available only in combination with rod end Style 4 or Style 8.

¹⁵ See Section C for detailed information regarding standard metric rod end thread sizes.

Style 9 Minimum Stroke Table

Bore Ø	Rod Ø	Minimum Stroke
1.00 - 4.00	All	None
5.00	2.000	None
	2.500	1.000
	3.000	1.375
	3.500	1.625
6.00	2.500	None
	3.000	1.375
	3.500	1.375
	4.000	2.000
8.00	3.500	1.500
	4.000	1.500
	5.000	2.875
	5.500	3.625



Rod End Dimensions

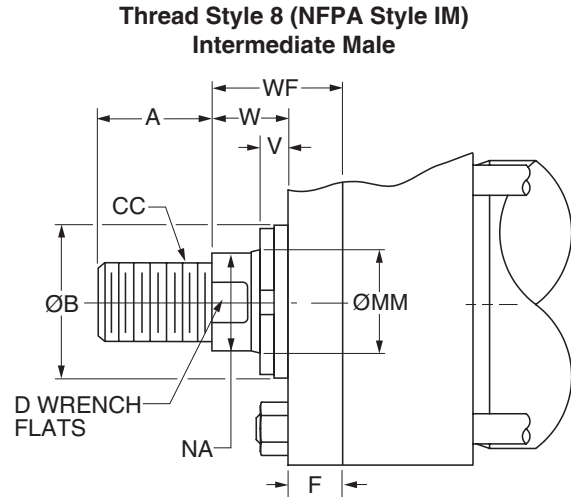
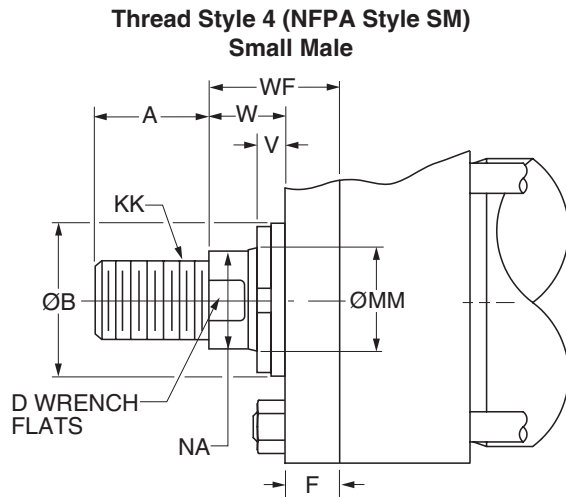

Rod End Dimensions

Bore Ø	Rod No.	MM Rod Ø	Thread		A	B Ø +.000 -.002	D	F	NA	V	W	WF
			Style 8 CC	Style 4 KK								
1.00	1 (Std.)	0.500	7/16-20	5/16-24	0.63	0.999	0.38	0.38	0.44	0.25	0.63	1.00
	2	0.625	1/2-20	7/16-20	0.75	1.124	0.50	0.38	0.56	0.25	0.63	1.00
1.50	1 (Std.)	0.625	1/2-20	7/16-20	0.75	1.124	0.50	0.38	0.56	0.25	0.63	1.00
	2	1.000	7/8-14	3/4-16	1.13	1.499	0.88	0.38	0.94	0.50	1.00	1.38
2.00	1 (Std.)	0.625	1/2-20	7/16-20	0.75	1.124	0.50	0.38	0.56	0.25	0.63	1.00
	2	1.375	1 1/4-12	1-14	1.63	1.999	1.13	0.38	1.31	0.63	1.25	1.63
	3	1.000	7/8-14	3/4-16	1.13	1.499	0.88	0.38	0.94	0.50	1.00	1.38
2.50	1 (Std.)	1.000	7/8-14	3/4-16	1.13	1.499	0.88	0.38	0.94	0.50	1.00	1.38
	2	1.750	1 1/2-12	1 1/4-12	2.00	2.374	1.50	0.38	1.69	0.75	1.50	1.88
	3	1.375	1 1/4-12	1-14	1.63	1.999	1.13	0.38	1.31	0.63	1.25	1.63
	7	0.625	1/2-20	7/16-20	0.75	1.124	0.50	0.38	0.56	0.25	0.63	1.00
3.25	1 (Std.)	1.000	7/8-14	3/4-16	1.13	1.499	0.88	0.63	0.94	0.25	0.75	1.38
	2	2.000	1 3/4-12	1 1/2-12	2.25	2.624	1.69	0.63	1.94	0.50	1.38	2.00
	3	1.375	1 1/4-12	1-14	1.63	1.999	1.13	0.63	1.31	0.38	1.00	1.63
	4	1.750	1 1/2-12	1 1/4-12	2.00	2.374	1.50	0.63	1.69	0.50	1.25	1.88
4.00	1 (Std.)	1.375	1 1/4-12	1-14	1.63	1.999	1.13	0.63	1.31	0.38	1.00	1.63
	2	2.500	2 1/4-12	1 7/8-12	3.00	3.124	2.06	0.63	2.38	0.63	1.63	2.25
	3	1.750	1 1/2-12	1 1/4-12	2.00	2.374	1.50	0.63	1.69	0.50	1.25	1.88
	4	2.000	1 3/4-12	1 1/2-12	2.25	2.624	1.69	0.63	1.94	0.50	1.38	2.00
	7	1.000	7/8-14	3/4-16	1.13	1.499	0.88	0.63	0.94	0.25	0.75	1.38
5.00	1 (Std.)	1.750	1 1/2-12	1 1/4-12	2.00	2.374	1.50	0.63	1.69	0.50	1.25	1.88
	2	3.500	3 1/4-12	2 1/2-12	3.50	4.249	3.00	0.63	3.38	0.63	1.63	2.25
	3	2.000	1 3/4-12	1 1/2-12	2.25	2.624	1.69	0.63	1.94	0.50	1.38	2.00
	4	2.500	2 1/4-12	1 7/8-12	3.00	3.124	2.06	0.63	2.38	0.63	1.63	2.25
	5	3.000	2 3/4-12	2 1/4-12	3.50	3.749	2.63	0.63	2.88	0.63	1.63	2.25
	7	1.000	7/8-14	3/4-16	1.13	1.499	0.88	0.63	0.94	0.25	0.75	1.38
	8	1.375	1 1/4-12	1-14	1.63	1.999	1.13	0.63	1.31	0.38	1.00	1.63

“Special” Thread Style 3

Special thread, extension, rod eye, blank, etc., are also available.

To order, specify “Style 3” and give desired dimensions for KK, A, W or WF. If otherwise special, furnish dimensioned sketch.



Rod End Dimensions

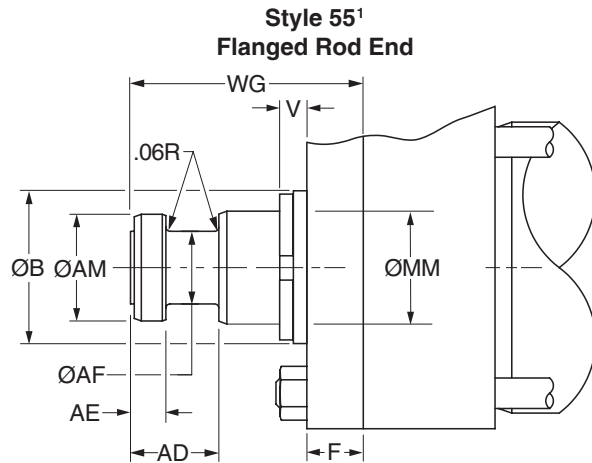
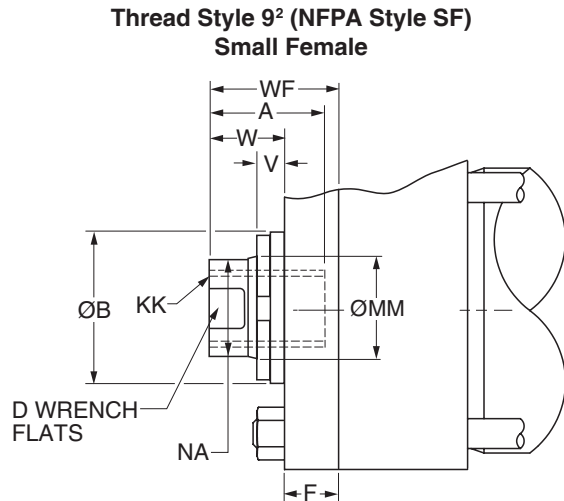

Rod End Dimensions

Bore Ø	Rod No.	MM Rod Ø	Thread Style 9 KK	Rod Extensions and Pilot Dimensions												
				A	AD	AE +.001 -.001	AF Ø	AM Ø	B Ø +.000 -.002	D	F	NA	V	W	WF	WG
1.00	1 (Std.)	0.500	5/16-24	0.63	—	—	—	—	0.999	0.38	0.38	0.44	0.25	0.63	1.00	—
	2	0.625	7/16-20	0.75	0.63	0.25	0.38	0.57	1.124	0.50	0.38	0.56	0.25	0.63	1.00	1.75
1.50	1 (Std.)	0.625	7/16-20	0.75	0.63	0.25	0.38	0.57	1.124	0.50	0.38	0.56	0.25	0.63	1.00	1.75
	2	1.000	3/4-16	1.13	0.94	0.38	0.69	0.95	1.499	0.88	0.38	0.94	0.50	1.00	1.38	2.38
2.00	1 (Std.)	0.625	7/16-20	0.75	0.63	0.25	0.38	0.57	1.124	0.50	0.38	0.56	0.25	0.63	1.00	1.75
	2	1.375	1-14	1.63	1.06	0.38	0.88	1.32	1.999	1.13	0.38	1.31	0.63	1.25	1.63	2.75
	3	1.000	3/4-16	1.13	0.94	0.38	0.69	0.95	1.499	0.88	0.38	0.94	0.50	1.00	1.38	2.38
2.50	1 (Std.)	1.000	3/4-16	1.13	0.94	0.38	0.69	0.95	1.499	0.88	0.38	0.94	0.50	1.00	1.38	2.38
	2	1.750	1 1/4-12	2.00	1.31	0.50	1.13	1.70	2.374	1.50	0.38	1.69	0.75	1.50	1.88	3.13
	3	1.375	1-14	1.63	1.06	0.38	0.88	1.32	1.999	1.13	0.38	1.31	0.63	1.25	1.63	2.75
	7	0.625	7/16-20	0.75	0.63	0.25	0.38	0.57	1.124	0.50	0.38	0.56	0.25	0.63	1.00	1.75
3.25	1 (Std.)	1.000	3/4-16	1.13	0.94	0.38	0.69	0.95	1.499	0.88	0.63	0.94	0.25	0.75	1.38	2.38
	2	2.000	1 1/2-12	2.25	1.69	0.63	1.38	1.95	2.624	1.69	0.63	1.94	0.50	1.38	2.00	3.75
	3	1.375	1-14	1.63	1.06	0.38	0.88	1.32	1.999	1.13	0.63	0.94	0.38	1.00	1.63	2.75
	4	1.750	1 1/4-12	2.00	1.31	0.50	1.13	1.70	2.374	1.50	0.63	1.69	0.50	1.25	1.88	3.13
4.00	1 (Std.)	1.375	1-14	1.63	1.06	0.38	0.88	1.32	1.999	1.13	0.63	0.94	0.38	1.00	1.63	2.75
	2	2.500	1 7/8-12	3.00	1.94	0.75	1.75	2.45	3.124	2.06	0.63	2.38	0.63	1.63	2.25	4.50
	3	1.750	1 1/4-12	2.00	1.31	0.50	1.13	1.70	2.374	1.50	0.63	1.69	0.50	1.25	1.88	3.13
	4	2.000	1 1/2-12	2.25	1.69	0.63	1.38	1.95	2.624	1.69	0.63	1.94	0.50	1.38	2.00	3.75
	7	1.000	3/4-16	1.13	0.94	0.38	0.69	0.95	1.499	0.88	0.63	0.94	0.25	0.75	1.38	2.38
5.00	1 (Std.)	1.750	1 1/4-12	2.00	1.31	0.50	1.13	1.70	2.374	1.50	0.63	1.69	0.50	1.25	1.88	3.13
	2	3.500	2 1/2-12	3.50	2.69	1.00	2.50	3.45	4.249	3.00	0.63	3.38	0.63	1.63	2.25	5.63
	3	2.000	1 1/2-12	2.25	1.69	0.63	1.38	1.95	2.624	1.69	0.63	1.94	0.50	1.38	2.00	3.75
	4	2.500	1 7/8-12	3.00	1.94	0.75	1.75	2.45	3.124	2.06	0.63	2.38	0.63	1.63	2.25	4.50
	5	3.000	2 1/4-12	3.50	2.44	0.88	2.25	2.95	3.749	2.63	0.63	2.88	0.63	1.63	2.25	4.88
	7	1.000	3/4-16	1.13	0.94	0.38	0.69	0.95	1.499	0.88	0.63	0.94	0.25	0.75	1.38	2.38
	8	1.375	1-14	1.63	1.06	0.38	0.88	1.32	1.999	1.13	0.63	1.31	0.38	1.00	1.63	2.75

“Special” Thread Style 3

Special thread, extension, rod eye, blank, etc., are also available.

To order, specify “Style 3” and give desired dimensions for KK, A, W or WF. If otherwise special, furnish dimensioned sketch.

¹ For special WG dimension, specify “Style 3” and give desired dimension for WG. For other changes, place “S” in the model code, and describe rod end with dimensioned sketch.

² Style 9 stroke restrictions may apply. See Style 9 Minimum Stroke Table on How to Order page for details.



Tie Rods Extended Head End Mounting
Style TB
(NFPA Style MX3)

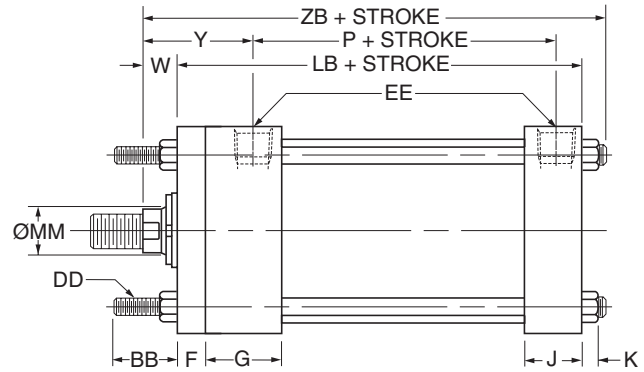
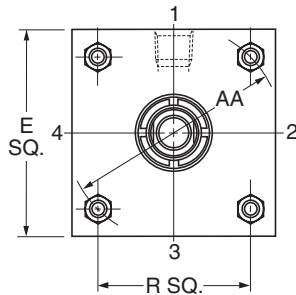
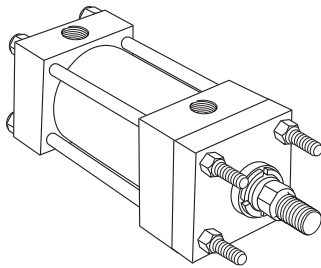

Table 1 – Dimensional and Mounting Data

Bore Ø	AA	BB	DD	E	EE		F	G	J	K	R	Add Stroke	
					NPTF ¹	SAE ²						LB	P
1.00 ³	1.53	0.75	10-24	4	1/4 ⁵	6	0.38	1.50	1.00	0.19	1.08	3.88	2.13
1.50	2.02	1.00	1/4-28	2.00	3/8 ⁵	6 ⁶	0.38	1.50	1.00	0.25	1.43	4.00	2.25
2.00	2.60	1.13	5/16-24	2.50	3/8 ⁵	6	0.38	1.50	1.00	0.31	1.84	4.00	2.25
2.50	3.10	1.13	5/16-24	3.00	3/8 ⁵	6	0.38	1.50	1.00	0.31	2.19	4.13	2.38
3.25	3.90	1.38	3/8-24	3.75	1/2	10	0.63	1.75	1.25	0.38	2.76	4.88	2.63
4.00	4.70	1.38	3/8-24	4.50	1/2	10	0.63	1.75	1.25	0.38	3.32	4.88	2.63
5.00	5.80	1.81	1/2-20	5.50	1/2	10	0.63	1.75	1.25	0.44	4.10	5.13	2.88

Table 2 – Dimensional and Mounting Data

Bore Ø	Rod No.	MM Rod Ø	W	Y	Add Stroke
					ZB Max
1.00	1 (Std.)	0.500	0.63	1.94	5.00
	2	0.625	0.63	1.94	5.00
1.50	1 (Std.)	0.625	0.63	1.94	5.06
	2	1.000	1.00	2.31	5.44
2.00	1 (Std.)	0.625	0.63	1.94	5.13
	2	1.375	1.25	2.56	5.75
2.50	1 (Std.)	1.000	1.00	2.31	5.63
	2	1.750	1.50	2.81	6.13
	3	1.375	1.25	2.56	5.88
	7	0.625	0.63	1.94	5.25
3.25	1 (Std.)	1.000	0.75	2.44	6.19
	2	2.000	1.38	3.06	6.81
	3	1.375	1.00	2.69	6.44
	4	1.750	1.25	2.94	6.69

Bore Ø	Rod No.	MM Rod Ø	W	Y	Add Stroke
					ZB Max
4.00	1 (Std.)	1.375	1.00	2.69	6.44
	2	2.500	1.63	3.31	7.06
	3	1.750	1.25	2.94	6.69
	4	2.000	1.38	3.06	6.81
5.00	7	1.000	0.75	2.44	6.19
	1 (Std.)	1.750	1.25	2.94	7.06
	2	3.500	1.63	3.31	7.44
	3	2.000	1.38	3.06	7.31
	4	2.500	1.63	3.31	7.44
	5	3.000	1.63	3.31	7.44
	7	1.000	0.75	2.44	6.56
	8	1.375	1.00	2.69	6.81

¹ NPTF ports will be furnished as standard unless SAE straight thread ports are specified.
² SAE straight thread ports are indicated by port number.
³ Cushion adjusting needle valve for 1.00" bore projects beyond sides of head and cap.
⁴ 1.00" bore 3L heads are rectangular — see 1.00" bore mounting information page.
⁵ On 1.00", 1.50", 2.00" and 2.50" bore sizes, the head end (only) pipe thread is not full depth on cylinders with No. 2 rods. Minimum of 3 full threads available.

⁶ Straight thread ports on 1.50" bore cap end, and head end with Code 2 rod, require an adapter fitting. Adapters are furnished as standard.
 Style TB (NFPA MX3) Head Tie Rods Extended, illustrated: Style TC (NFPA MX2), Cap Tie Rods Extended; and Style TD (NFPA MX1), Both Ends Tie Rod Extended area also available. All "T" styles can be dimensioned from Style TB drawing above. Basic Mounting (T) – NFPA MX0 – no tie rods extended can be supplied upon request.

Mounting Information – 1.00" to 6.00" Bore Series 3L

Head Rectangular Flange Mounting

Style J
(NFPA Style MF1)

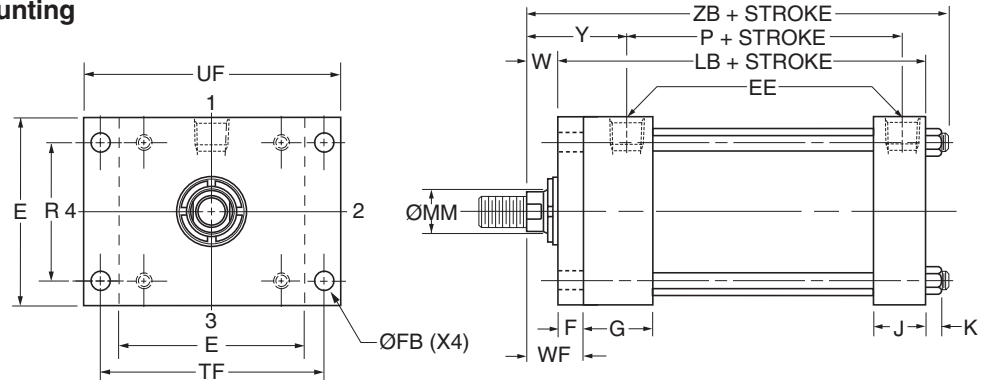
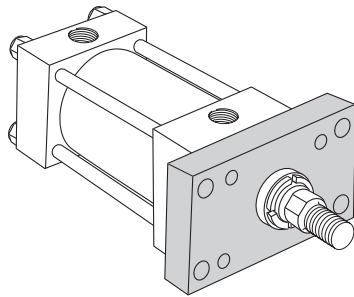

Table 1 – Dimensional and Mounting Data

Bore Ø	E	EE		F	FB Ø	G	J	K	R	TF	UF	Add Stroke	
		NPTF ¹	SAE ²									LB	P
1.00 ³	4	1/4 ⁵	6	0.38	0.25	1.50	1.00	0.19	1.08	2.00	2.50	3.88	2.13
1.50	2.00	3/8 ⁵	6 ⁶	0.38	0.31	1.50	1.00	0.25	1.43	2.75	3.38	4.00	2.25
2.00	2.50	3/8 ⁵	6	0.38	0.38	1.50	1.00	0.31	1.84	3.38	4.13	4.00	2.25
2.50	3.00	3/8 ⁵	6	0.38	0.38	1.50	1.00	0.31	2.19	3.88	4.63	4.13	2.38
3.25	3.75	1/2	10	0.63	0.44	1.75	1.25	0.38	2.76	4.69	5.50	4.88	2.63
4.00	4.50	1/2	10	0.63	0.44	1.75	1.25	0.38	3.32	5.44	6.25	4.88	2.63
5.00	5.50	1/2	10	0.63	0.56	1.75	1.25	0.44	4.10	6.63	7.63	5.13	2.88
6.00	6.50	3/4	12	0.75	0.56	2.00	1.50	0.44	4.88	7.63	8.63	5.75	3.13

Table 2 – Dimensional and Mounting Data

Bore Ø	Rod No.	MM Rod Ø	W	WF	Y	Add Stroke	ZB Max
1.00	1 (Std.)	0.500	0.63	1.00	1.94	5.00	
	2	0.625	0.63	1.00	1.94	5.00	
1.50	1 (Std.)	0.625	0.63	1.00	1.94	5.06	
	2	1.000	1.00	1.38	2.31	5.44	
2.00	1 (Std.)	0.625	0.63	1.00	1.94	5.13	
	2	1.375	1.25	1.63	2.56	5.75	
	3	1.000	1.00	1.38	2.31	5.50	
2.50	1 (Std.)	1.000	1.00	1.38	2.31	5.63	
	2	1.750	1.50	1.88	2.81	6.13	
	3	1.375	1.25	1.63	2.56	5.88	
	7	0.625	0.63	1.00	1.94	5.25	
3.25	1 (Std.)	1.000	0.75	1.38	2.44	6.19	
	2	2.000	1.38	2.00	3.06	6.81	
	3	1.375	1.00	1.63	2.69	6.44	
	4	1.750	1.25	1.88	2.94	6.69	
4.00	1 (Std.)	1.375	1.00	1.63	2.69	6.44	
	2	2.500	1.63	2.25	3.31	7.06	
	3	1.750	1.25	1.88	2.94	6.69	
	4	2.000	1.38	2.00	3.06	6.81	
	7	1.000	0.75	1.38	2.44	6.19	

¹ NPTF ports will be furnished as standard unless SAE straight thread ports are specified.
² SAE straight thread ports are indicated by port number.

Table 3 – Maximum Operating Pressure

Bore Ø	Rod No.	MM Rod Ø	W	WF	Y	Add Stroke	Max. psi Push			
							Rod Code			
							1	2	3	4
1.00	1 (Std.)	1.750	1.25	1.88	2.94	7.06				
	2	3.500	1.63	2.25	3.31	7.44				
	3	2.000	1.38	2.00	3.06	7.31				
	4	2.500	1.63	2.25	3.31	7.44				
	5	3.000	1.63	2.25	3.31	7.44				
	7	1.000	0.75	1.38	2.44	6.56				
	8	1.375	1.00	1.63	2.69	6.81				
	1 (Std.)	1.750	1.13	1.88	3.06	7.56				
5.00	2	4.000	1.50	2.25	3.44	7.94				
	3	2.000	1.25	2.00	3.19	7.69				
	4	2.500	1.50	2.25	3.44	7.44				
	5	3.000	1.50	2.25	3.44	7.44				
	6	3.500	1.50	2.25	3.44	7.44				
	7	1.375	0.88	1.63	2.81	7.31				
	6.00	1 (Std.)	1.750	1.13	1.88	3.06	7.56			
2		4.000	1.50	2.25	3.44	7.94				
3		2.000	1.25	2.00	3.19	7.69				
4		2.500	1.50	2.25	3.44	7.44				
5		3.000	1.50	2.25	3.44	7.44				
Bore Ø							Max. psi Push			
							Rod Code			
							5	6	7	8
	2.50								700	
	3.25									
	4.00								900	
	5.00	450			600	800				
	6.00	650	600	700						

³ Cushion adjusting needle valve for 1.00" bore projects beyond sides of head and cap.
⁴ 1.00" bore 3L heads are rectangular — see 1.00" bore mounting information page.
⁵ On 1.00", 1.50", 2.00" and 2.50" bore sizes, the head end (only) pipe thread is not full depth on cylinders with No. 2 rods. Minimum of 3 full threads available.
⁶ Straight thread ports on 1.50" bore cap end, and head end with Code 2 rod, require an adapter fitting. Adapters are furnished as standard.



Mounting Information – 1.00" to 5.00" Bore Series 3L

Head Square Flange Mounting
Style JB
(NFPA Style MF5)

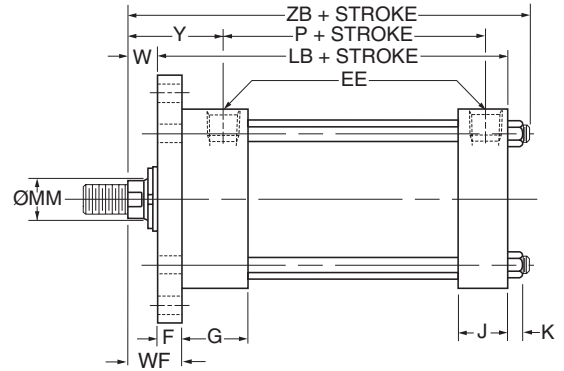
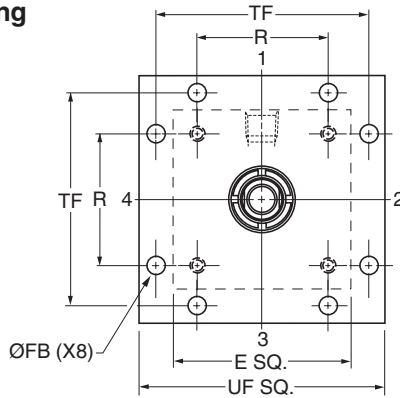
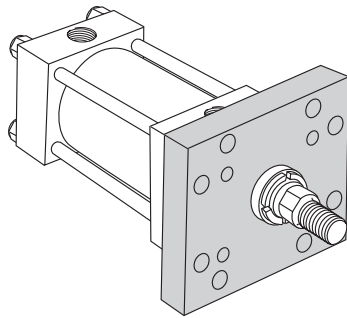

Table 1 – Dimensional and Mounting Data

Bore Ø	E	EE		F	FB Ø	G	J	K	R	TF	UF	Add Stroke	
		NPTF ¹	SAE ²									LB	P
1.00 ³	4	1/4 ⁵	6	0.38	0.25	1.50	1.00	0.19	1.08	2.00	2.50	3.88	2.13
1.50	2.00	3/8 ⁵	6 ⁶	0.38	0.31	1.50	1.00	0.25	1.43	2.75	3.38	4.00	2.25
2.00	2.50	3/8 ⁵	6	0.38	0.38	1.50	1.00	0.31	1.84	3.38	4.13	4.00	2.25
2.50	3.00	3/8 ⁵	6	0.38	0.38	1.50	1.00	0.31	2.19	3.88	4.63	4.13	2.38
3.25	3.75	1/2	10	0.63	0.44	1.75	1.25	0.38	2.76	4.69	5.50	4.88	2.63
4.00	4.50	1/2	10	0.63	0.44	1.75	1.25	0.38	3.32	5.44	6.25	4.88	2.63
5.00	5.50	1/2	10	0.63	0.56	1.75	1.25	0.44	4.10	6.63	7.63	5.13	2.88

Table 2 – Dimensional and Mounting Data

Bore Ø	Rod No.	MM Rod Ø	W	WF	Y	Add Stroke
						ZB Max.
1.00	1 (Std.)	0.500	0.63	1.00	1.94	5.00
	2	0.625	0.63	1.00	1.94	5.00
1.50	1 (Std.)	0.625	0.63	1.00	1.94	5.06
	2	1.000	1.00	1.38	2.31	5.44
2.00	1 (Std.)	0.625	0.63	1.00	1.94	5.13
	2	1.375	1.25	1.63	2.56	5.75
	3	1.000	1.00	1.38	2.31	5.50
2.50	1 (Std.)	1.000	1.00	1.38	2.31	5.63
	2	1.750	1.50	1.88	2.81	6.13
	3	1.375	1.25	1.63	2.56	5.88
	7	0.625	0.63	1.00	1.94	5.25
3.25	1 (Std.)	1.000	0.75	1.38	2.44	6.19
	2	2.000	1.38	2.00	3.06	6.81
	3	1.375	1.00	1.63	2.69	6.44
	4	1.750	1.25	1.88	2.94	6.69

Bore Ø	Rod No.	MM Rod Ø	W	WF	Y	Add Stroke
						ZB Max.
4.00	1 (Std.)	1.375	1.00	1.63	2.69	6.44
	2	2.500	1.63	2.25	3.31	7.06
	3	1.750	1.25	1.88	2.94	6.69
	4	2.000	1.38	2.00	3.06	6.81
5.00	7	1.000	0.75	1.38	2.44	6.19
	1 (Std.)	1.750	1.25	1.88	2.94	7.06
	2	3.500	1.63	2.25	3.31	7.44
	3	2.000	1.38	2.00	3.06	7.31
	4	2.500	1.63	2.25	3.31	7.44
	5	3.000	1.63	2.25	3.31	7.44
	7	1.000	0.75	1.38	2.44	6.56
	8	1.375	1.00	1.63	2.69	6.81

¹ NPTF ports will be furnished as standard unless SAE straight thread ports are specified.

² SAE straight thread ports are indicated by port number.

³ Cushion adjusting needle valve for 1.00" bore projects beyond sides of head and cap.

⁴ 1.00" bore 3L heads are rectangular — see 1.00" bore mounting information page.

⁵ On 1.00", 1.50", 2.00" and 2.50" bore sizes, the head end (only) pipe thread is not full depth on cylinders with No. 2 rods. Minimum of 3 full threads available.

⁶ Straight thread ports on 1.50" bore cap end, and head end with Code 2 rod, require an adapter fitting. Adapters are furnished as standard.

Mounting Information – 1.50" to 6.00" Bore Series 3L

Head Rectangular Mounting
Style JJ³

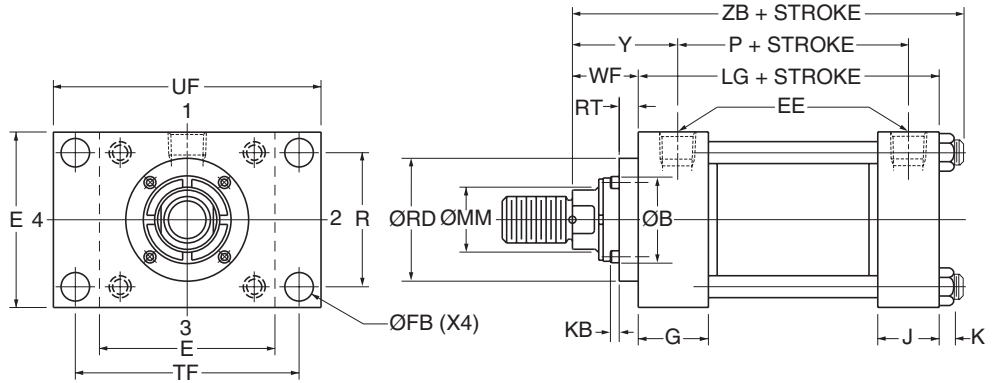
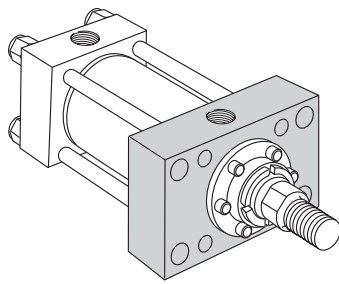

Table 1 – Dimensional and Mounting Data

Bore Ø	E	EE		FB Ø	G	J	K	R	TF	UF	Add Stroke	
		NPTF ¹	SAE ²								LG	P
1.50	2.00	3/8 ⁴	6 ⁵	0.31	1.50	1.00	0.25	1.43	2.31	2.75	3.63	2.25
2.00	2.50	3/8 ⁴	6	0.38	1.50	1.00	0.31	1.84	2.88	3.38	3.63	2.25
2.50	3.00	3/8 ⁴	6	0.38	1.50	1.00	0.31	2.19	3.25	3.75	3.75	2.38
3.25	3.75	1/2	10	0.44	1.75	1.25	0.38	2.76	4.00	4.63	4.25	2.63
4.00	4.50	1/2	10	0.44	1.75	1.25	0.38	3.32	4.50	5.13	4.25	2.63
5.00	5.50	1/2	10	0.56	1.75	1.25	0.44	4.10	5.63	6.44	4.50	2.88
6.00	6.50	3/4	12	0.56	2.00	1.50	0.44	4.88	6.44	7.25	5.00	3.13

Table 2 – Dimensional and Mounting Data

Bore Ø	Rod No.	MM Rod Ø	B Ø +.000 -0.002	KB	RD Ø Max	RT	WF	Y	Add Stroke
									ZB Max
1.50	1 (Std.)	0.625	1.124	0.19	1.967	0.25	1.00	1.94	5.06
2.00	1 (Std.)	0.625	1.124	0.19	1.967	0.25	1.00	1.94	5.13
	3	1.000	1.499	0.25	2.467	0.38	1.38	2.31	5.50
2.50	1 (Std.)	1.000	1.499	0.25	2.467	0.38	1.38	2.31	5.63
	3	1.375	1.999	0.25	2.967	0.38	1.63	2.56	5.88
3.25	1 (Std.)	1.000	1.499	0.25	2.467	0.38	1.38	2.44	6.19
	3	1.375	1.999	0.25	2.967	0.38	1.63	2.69	6.44
4.00	1 (Std.)	1.375	1.999	0.25	2.967	0.38	1.63	2.69	6.44
	3	1.750	2.374	0.25	3.467	0.38	1.88	2.94	6.69
5.00	1 (Std.)	1.750	2.374	0.25	3.467	0.38	1.88	2.94	7.06
	3	2.000	2.624	0.25	3.717	0.38	2.00	3.06	7.31
6.00	1 (Std.)	1.750	2.374	0.25	3.467	0.38	1.88	3.06	7.56
	3	2.000	2.624	0.25	3.717	0.38	2.00	3.19	7.69

¹ NPTF ports will be furnished as standard unless SAE straight thread ports are specified.

² SAE straight thread ports are indicated by port number.

³ Parker Style JJ Mount is a Non-NFPA Mount.

⁴ On 1.00", 1.50", 2.00" and 2.50" bore sizes, the head end (only) pipe thread is not full depth on cylinders with No. 2 rods. Minimum of 3 full threads available.

⁵ Straight thread ports on 1.50" bore cap end, and head end with Code 2 rod, require an adapter fitting. Adapters are furnished as standard.



Mounting Information – 1.00" to 6.00" Bore Series 3L

**Cap Rectangular Flange Mounting
Style H
(NFPA Style MF2)**

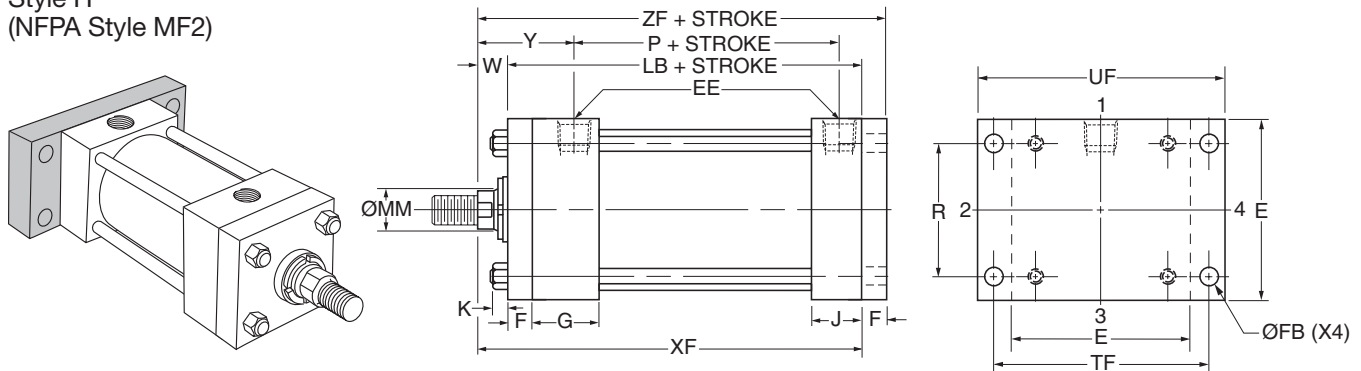

Table 1 – Dimensional and Mounting Data

Bore Ø	E	EE		F	FB Ø	G	J	K	R	TF	UF	Add Stroke	
		NPTF ¹	SAE ²									LB	P
1.00 ⁵	4	1/4 ⁵	6	0.38	0.25	1.50	1.00	0.19	1.08	2.00	2.50	3.88	2.13
1.50	2.00	3/8 ⁵	6 ⁶	0.38	0.31	1.50	1.00	0.25	1.43	2.75	3.38	4.00	2.25
2.00	2.50	3/8 ⁵	6	0.38	0.38	1.50	1.00	0.31	1.84	3.38	4.13	4.00	2.25
2.50	3.00	3/8 ⁵	6	0.38	0.38	1.50	1.00	0.31	2.19	3.88	4.63	4.13	2.38
3.25	3.75	1/2	10	0.63	0.44	1.75	1.25	0.38	2.76	4.69	5.50	4.88	2.63
4.00	4.50	1/2	10	0.63	0.44	1.75	1.25	0.38	3.32	5.44	6.25	4.88	2.63
5.00	5.50	1/2	10	0.63	0.56	1.75	1.25	0.44	4.10	6.63	7.63	5.13	2.88
6.00	6.50	3/4	12	0.75	0.56	2.00	1.50	0.44	4.88	7.63	8.63	5.75	3.13

Table 2 – Dimensional and Mounting Data

Bore Ø	Rod No.	MM Rod Ø	W	Y	Add Stroke	
					XF	ZF
1.00	1 (Std.)	0.500	0.63	1.94	4.50	4.88
	2	0.625	0.63	1.94	4.50	4.88
1.50	1 (Std.)	0.625	0.63	1.94	4.63	5.00
	2	1.000	1.00	2.31	5.00	5.38
2.00	1 (Std.)	0.625	0.63	1.94	4.63	5.00
	2	1.375	1.25	2.56	5.25	5.63
	3	1.000	1.00	2.31	5.00	5.38
2.50	1 (Std.)	1.000	1.00	2.31	5.13	5.50
	2	1.750	1.50	2.81	5.63	6.00
	3	1.375	1.25	2.56	5.38	5.75
	7	0.625	0.63	1.94	4.75	5.13
3.25	1 (Std.)	1.000	0.75	2.44	5.63	6.25
	2	2.000	1.38	3.06	6.25	6.88
	3	1.375	1.00	2.69	5.88	6.50
	4	1.750	1.25	2.94	6.13	6.75
4.00	1 (Std.)	1.375	1.00	2.69	5.88	6.50
	2	2.500	1.63	3.31	6.50	7.13
	3	1.750	1.25	2.94	6.13	6.75
	4	2.000	1.38	3.06	6.25	6.88
	7	1.000	0.75	2.44	5.63	6.25

Bore Ø	Rod No.	MM Rod Ø	W	Y	Add Stroke	
					XF	ZF
5.00	1 (Std.)	1.750	1.25	2.94	6.38	7.00
	2	3.500	1.63	3.31	6.75	7.38
	3	2.000	1.38	3.06	6.50	7.13
	4	2.500	1.63	3.31	6.75	7.38
	5	3.000	1.63	3.31	6.75	7.38
	7	1.000	0.75	2.44	5.88	6.50
	8	1.375	1.00	2.69	6.13	6.75
6.00	1 (Std.)	1.750	1.13	3.06	6.88	7.63
	2	4.000	1.50	3.44	7.25	8.00
	3	2.000	1.25	3.19	7.00	7.75
	4	2.500	1.50	3.44	7.25	8.00
	5	3.000	1.50	3.44	7.25	8.00
	6	3.500	1.50	3.44	7.25	8.00
	7	1.375	0.88	2.81	6.63	7.38

¹ NPTF ports will be furnished as standard unless SAE straight thread ports are specified.
² SAE straight thread ports are indicated by port number.
³ Cushion adjusting needle valve for 1.00" bore projects beyond sides of head and cap.

⁴ 1.00" bore 3L heads are rectangular — see 1.00" bore mounting information page.
⁵ On 1.00", 1.50", 2.00" and 2.50" bore sizes, the head end (only) pipe thread is not full depth on cylinders with No. 2 rods. Minimum of 3 full threads available.
⁶ Straight thread ports on 1.50" bore cap end, and head end with Code 2 rod, require an adapter fitting. Adapters are furnished as standard.



Mounting Information – 1.00" to 5.00" Bore Series 3L

Cap Square Flange Mounting

Style HB
(NFPA Style MF6)

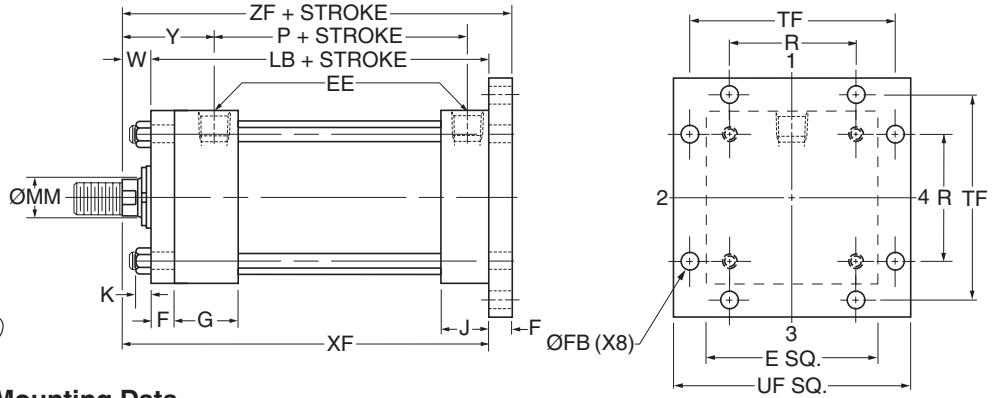
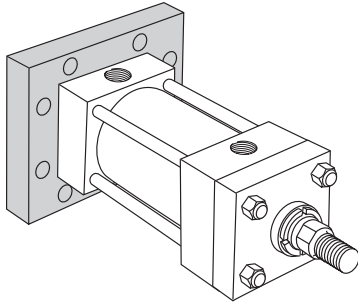

Table 1 – Dimensional and Mounting Data

Bore Ø	E	EE		F	FB Ø	G	J	K	R	TF	UF	Add Stroke	
		NPTF ¹	SAE ²									LB	P
1.00 ³	4	1/4 ⁵	6	0.38	0.25	1.50	1.00	0.19	1.08	2.00	2.50	3.88	2.13
1.50	2.00	3/8 ⁵	6 ⁶	0.38	0.31	1.50	1.00	0.25	1.43	2.75	3.38	4.00	2.25
2.00	2.50	3/8 ⁵	6	0.38	0.38	1.50	1.00	0.31	1.84	3.38	4.13	4.00	2.25
2.50	3.00	3/8 ⁵	6	0.38	0.38	1.50	1.00	0.31	2.19	3.88	4.63	4.13	2.38
3.25	3.75	1/2	10	0.63	0.44	1.75	1.25	0.38	2.76	4.69	5.50	4.88	2.63
4.00	4.50	1/2	10	0.63	0.44	1.75	1.25	0.38	3.32	5.44	6.25	4.88	2.63
5.00	5.50	1/2	10	0.63	0.56	1.75	1.25	0.44	4.10	6.63	7.63	5.13	2.88

Table 2 – Dimensional and Mounting Data

Bore Ø	Rod No.	MM Rod Ø	W	Y	Add Stroke	
					XF	ZF
1.00	1 (Std.)	0.500	0.63	1.94	4.50	4.88
	2	0.625	0.63	1.94	4.50	4.88
1.50	1 (Std.)	0.625	0.63	1.94	4.63	5.00
	2	1.000	1.00	2.31	5.00	5.38
2.00	1 (Std.)	0.625	0.63	1.94	4.63	5.00
	2	1.375	1.25	2.56	5.25	5.63
	3	1.000	1.00	2.31	5.00	5.38
2.50	1 (Std.)	1.000	1.00	2.31	5.13	5.50
	2	1.750	1.50	2.81	5.63	6.00
	3	1.375	1.25	2.56	5.38	5.75
	7	0.625	0.63	1.94	4.75	5.13
3.25	1 (Std.)	1.000	0.75	2.44	5.63	6.25
	2	2.000	1.38	3.06	6.25	6.88
	3	1.375	1.00	2.69	5.88	6.50
	4	1.750	1.25	2.94	6.13	6.75

Bore Ø	Rod No.	MM Rod Ø	W	Y	Add Stroke	
					XF	ZF
4.00	1 (Std.)	1.375	1.00	2.69	5.88	6.50
	2	2.500	1.63	3.31	6.50	7.13
	3	1.750	1.25	2.94	6.13	6.75
	4	2.000	1.38	3.06	6.25	6.88
5.00	7	1.000	0.75	2.44	5.63	6.25
	1 (Std.)	1.750	1.25	2.94	6.38	7.00
	2	3.500	1.63	3.31	6.75	7.38
	3	2.000	1.38	3.06	6.50	7.13
	4	2.500	1.63	3.31	6.75	7.38
	5	3.000	1.63	3.31	6.75	7.38
	7	1.000	0.75	2.44	5.88	6.50
	8	1.375	1.00	2.69	6.13	6.75

¹ NPTF ports will be furnished as standard unless SAE straight thread ports are specified.

² SAE straight thread ports are indicated by port number.

³ Cushion adjusting needle valve for 1.00" bore projects beyond sides of head and cap.

⁴ 1.00" bore 3L heads are rectangular — see 1.00" bore mounting information page.

⁵ On 1.00", 1.50", 2.00" and 2.50" bore sizes, the head end (only) pipe thread is not full depth on cylinders with No. 2 rods. Minimum of 3 full threads available.

⁶ Straight thread ports on 1.50" bore cap end, and head end with Code 2 rod, require an adapter fitting. Adapters are furnished as standard.



Mounting Information – 1.00" to 5.00" Bore Series 3L

Side Lug Mounting

Style C
(NFPA Style MS2)

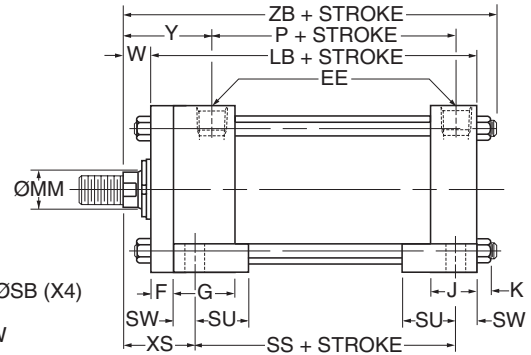
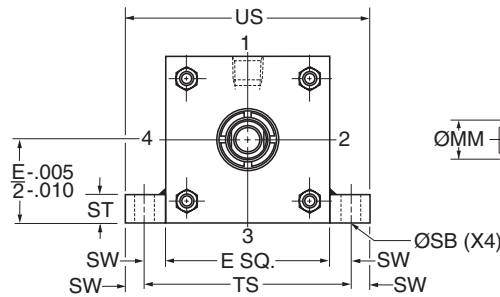
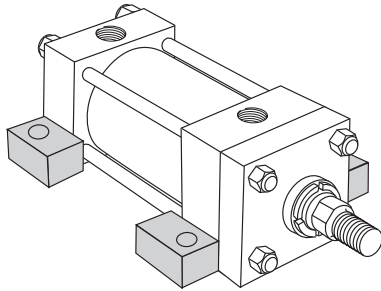

Table 1 – Dimensional and Mounting Data

Bore Ø	E	EE		F	G	J	K	SB Ø	ST	SU	SW	TS	US	Add Stroke		
		NPTF ¹	SAE ²											LB	P	SS
1.00 ³	4	1/4 ⁵	6	0.38	1.50	1.00	0.19	0.28	0.31	0.75	0.31	2.13	2.75	3.88	2.13	2.88
1.50	2.00	3/8 ⁵	6 ⁶	0.38	1.50	1.00	0.25	0.44	0.50	0.94	0.38	2.75	3.50	4.00	2.25	2.88
2.00	2.50	3/8 ⁵	6	0.38	1.50	1.00	0.31	0.44	0.50	0.94	0.38	3.25	4.00	4.00	2.25	2.88
2.50	3.00	3/8 ⁵	6	0.38	1.50	1.00	0.31	0.44	0.50	0.94	0.38	3.75	4.50	4.13	2.38	3.00
3.25	3.75	1/2	10	0.63	1.75	1.25	0.38	0.56	0.75	1.25	0.50	4.75	5.75	4.88	2.63	3.25
4.00	4.50	1/2	10	0.63	1.75	1.25	0.38	0.56	0.75	1.25	0.50	5.50	6.50	4.88	2.63	3.25
5.00	5.50	1/2	10	0.63	1.75	1.25	0.44	0.81	1.00	1.56	0.69	6.88	8.25	5.13	2.88	3.13

Table 2 – Dimensional and Mounting Data

Bore Ø	Rod No.	MM Rod Ø	W	XS	Y	Add Stroke
						ZB Max.
1.00	1 (Std.)	0.500	0.63	1.31	1.94	5.00
	2	0.625	0.63	1.31	1.94	5.00
1.50	1 (Std.)	0.625	0.63	1.38	1.94	5.06
	2	1.000	1.00	1.75	2.31	5.44
2.00	1 (Std.)	0.625	0.63	1.38	1.94	5.13
	2	1.375	1.25	2.00	2.56	5.75
	3	1.000	1.00	1.75	2.31	5.50
2.50	1 (Std.)	1.000	1.00	1.75	2.31	5.63
	2	1.750	1.50	2.25	2.81	6.13
	3	1.375	1.25	2.00	2.56	5.88
	7	0.625	0.63	1.38	1.94	5.25
3.25	1 (Std.)	1.000	0.75	1.88	2.44	6.19
	2	2.000	1.38	2.50	3.06	6.81
	3	1.375	1.00	2.13	2.69	6.44
	4	1.750	1.25	2.38	2.94	6.69

Bore Ø	Rod No.	MM Rod Ø	W	XS	Y	Add Stroke
						ZB Max.
4.00	1 (Std.)	1.375	1.00	2.13	2.69	6.44
	2	2.500	1.63	2.75	3.31	7.06
	3	1.750	1.25	2.38	2.94	6.69
	4	2.000	1.38	2.50	3.06	6.81
5.00	7	1.000	0.75	1.88	2.44	6.19
	1 (Std.)	1.750	1.25	2.56	2.94	7.06
	2	3.500	1.63	2.94	3.31	7.44
	3	2.000	1.38	2.69	3.06	7.31
	4	2.500	1.63	2.94	3.31	7.44
	5	3.000	1.63	2.94	3.31	7.44
	7	1.000	0.75	2.06	2.44	6.56
	8	1.375	1.00	2.31	2.69	6.81

¹ NPTF ports will be furnished as standard unless SAE straight thread ports are specified.

² SAE straight thread ports are indicated by port number.

³ Cushion adjusting needle valve for 1.00" bore projects beyond sides of head and cap.

⁴ 1.00" bore 3L heads are rectangular — see 1.00" bore mounting information page. E/2 for this bore is .750 -.005/-.010.

⁵ On 1.00", 1.50", 2.00" and 2.50" bore sizes, the head end (only) pipe thread is not full depth on cylinders with No. 2 rods. Minimum of 3 full threads available.

⁶ Straight thread ports on 1.50" bore cap end, and head end with Code 2 rod, require an adapter fitting. Adapters are furnished as standard.

Side Tapped Mounting
Style F
(NFPA Style MS4)

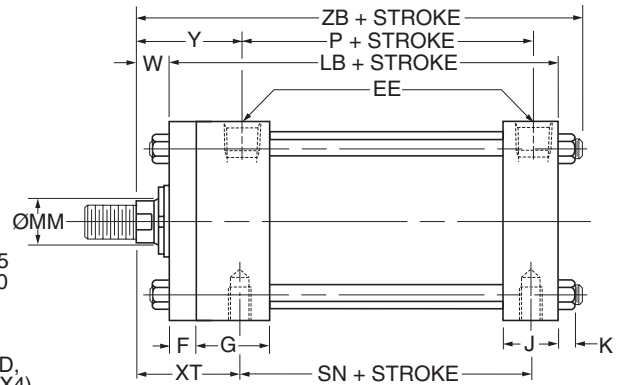
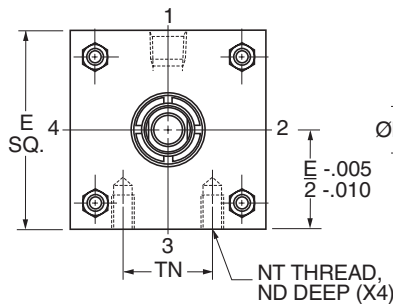
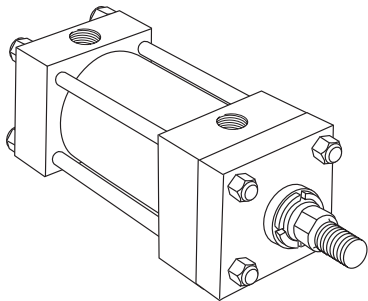

Table 1 – Dimensional and Mounting Data

Bore Ø	E	EE		F	G	J	K	ND	NT	TN	Add Stroke		
		NPTF ¹	SAE ²								LB	P	SN
1.00 ³	4	1/4 ⁵	6	0.38	1.50	1.00	0.19	0.25	10-24	0.56	3.88	2.13	2.13
1.50	2.00	3/8 ⁵	6 ⁶	0.38	1.50	1.00	0.25	0.19	1/4-20	0.63	4.00	2.25	2.25
2.00	2.50	3/8 ⁵	6	0.38	1.50	1.00	0.31	0.34	5/16-18	0.88	4.00	2.25	2.25
2.50	3.00	3/8 ⁵	6	0.38	1.50	1.00	0.31	0.44	3/8-16	1.25	4.13	2.38	2.38
3.25	3.75	1/2	10	0.63	1.75	1.25	0.38	0.50	1/2-13	1.50	4.88	2.63	2.63
4.00	4.50	1/2	10	0.63	1.75	1.25	0.38	0.63	1/2-13	2.06	4.88	2.63	2.63
5.00	5.50	1/2	10	0.63	1.75	1.25	0.44	0.75	5/8-11	2.69	5.13	2.88	2.88

Table 2 – Dimensional and Mounting Data

Bore Ø	Rod No.	MM Rod Ø	W	XT	Y	Add Stroke
						ZB Max.
1.00	1 (Std.)	0.500	0.63	1.94	1.94	5.00
	2	0.625	0.63	1.94	1.94	5.00
1.50	1 (Std.)	0.625	0.63	1.94	1.94	5.06
	2	1.000	1.00	2.31	2.31	5.44
2.00	1 (Std.)	0.625	0.63	1.94	1.94	5.13
	2	1.375	1.25	2.56	2.56	5.75
	3	1.000	1.00	2.31	2.31	5.50
2.50	1 (Std.)	1.000	1.00	2.31	2.31	5.63
	2	1.750	1.50	2.81	2.81	6.13
	3	1.375	1.25	2.56	2.56	5.88
	7	0.625	0.63	1.94	1.94	5.25
3.25	1 (Std.)	1.000	0.75	2.44	2.44	6.19
	2	2.000	1.38	3.06	3.06	6.81
	3	1.375	1.00	2.69	2.69	6.44
	4	1.750	1.25	2.94	2.94	6.69

Bore Ø	Rod No.	MM Rod Ø	W	XT	Y	Add Stroke
						ZB Max.
4.00	1 (Std.)	1.375	1.00	2.69	2.69	6.44
	2	2.500	1.63	3.31	3.31	7.06
	3	1.750	1.25	2.94	2.94	6.69
	4	2.000	1.38	3.06	3.06	6.81
5.00	7	1.000	0.75	2.44	2.44	6.19
	1 (Std.)	1.750	1.25	2.94	2.94	7.06
	2	3.500	1.63	3.31	3.31	7.44
	3	2.000	1.38	3.06	3.06	7.31
	4	2.500	1.63	3.31	3.31	7.44
	5	3.000	1.63	3.31	3.31	7.44
	7	1.000	0.75	2.44	2.44	6.56
	8	1.375	1.00	2.69	2.69	6.81

¹ NPTF ports will be furnished as standard unless SAE straight thread ports are specified.

² SAE straight thread ports are indicated by port number.

³ Cushion adjusting needle valve for 1.00" bore projects beyond sides of head and cap.

⁴ 1.00" bore 3L heads are rectangular — see 1.00" bore mounting information page. E/2 for this bore is .750 $-.005/-0.010$.

⁵ On 1.00", 1.50", 2.00" and 2.50" bore sizes, the head end (only) pipe thread is not full depth on cylinders with No. 2 rods. Minimum of 3 full threads available.

⁶ Straight thread ports on 1.50" bore cap end, and head end with Code 2 rod, require an adapter fitting. Adapters are furnished as standard.



Mounting Information – 1.00" to 5.00" Bore Series 3L

Cap Fixed Clevis Mounting
Style BB
(NFPA Style MP1)

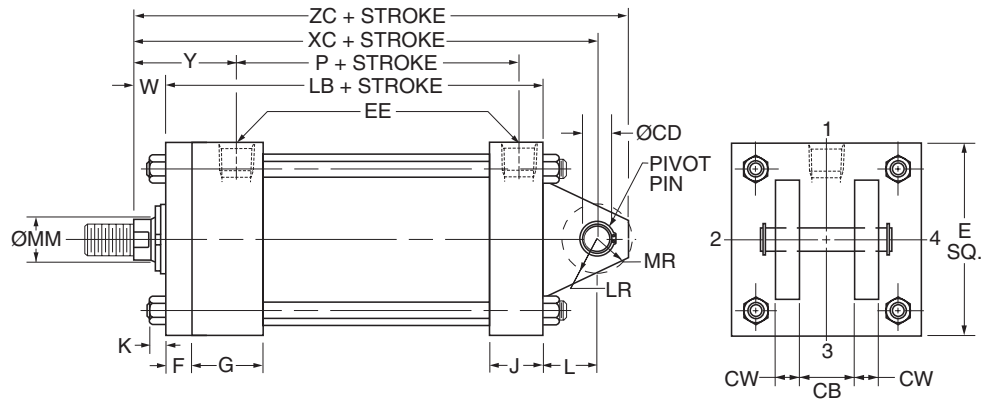
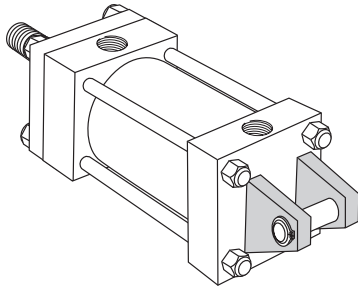

Table 1 – Dimensional and Mounting Data

Bore Ø	CB	CD Ø +.000 -.002	CW	E	EE		F	G	J	K	L	LR	MR	Add Stroke	
					NPTF ¹	SAE ²								LB	P
1.00 ³	7	0.441 ⁷	7	4	1/4 ⁵	6	0.38	1.50	1.00	0.19	0.50	0.50	0.50	3.88	2.13
1.50	0.75	0.501	0.50	2.00	3/8 ⁵	6 ⁶	0.38	1.50	1.00	0.25	0.75	0.75	0.63	4.00	2.25
2.00	0.75	0.501	0.50	2.50	3/8 ⁵	6	0.38	1.50	1.00	0.31	0.75	0.75	0.63	4.00	2.25
2.50	0.75	0.501	0.50	3.00	3/8 ⁵	6	0.38	1.50	1.00	0.31	0.75	0.75	0.63	4.13	2.38
3.25	1.25	0.751	0.63	3.75	1/2	10	0.63	1.75	1.25	0.38	1.25	1.00	0.94	4.88	2.63
4.00	1.25	0.751	0.63	4.50	1/2	10	0.63	1.75	1.25	0.38	1.25	1.00	0.94	4.88	2.63
5.00	1.25	0.751	0.63	5.50	1/2	10	0.63	1.75	1.25	0.44	1.25	1.00	0.94	5.13	2.88

Table 2 – Dimensional and Mounting Data

Bore Ø	Rod No.	MM Rod Ø	W	Y	Add Stroke	
					XC	ZC
1.00	1 (Std.)	0.500	0.63	1.94	5.00	5.44
	2	0.625	0.63	1.94	5.00	5.44
1.50	1 (Std.)	0.625	0.63	1.94	5.38	5.88
	2	1.000	1.00	2.31	5.75	6.25
2.00	1 (Std.)	0.625	0.63	1.94	5.38	5.88
	2	1.375	1.25	2.56	6.00	6.50
2.50	1 (Std.)	1.000	1.00	2.31	5.88	6.38
	2	1.750	1.50	2.81	6.38	6.88
	3	1.375	1.25	2.56	6.13	6.63
	7	0.625	0.63	1.94	5.50	6.00
3.25	1 (Std.)	1.000	0.75	2.44	6.88	7.63
	2	2.000	1.38	3.06	7.50	8.25
	3	1.375	1.00	2.69	7.13	7.88
	4	1.750	1.25	2.94	7.38	8.13

Bore Ø	Rod No.	MM Rod Ø	W	Y	Add Stroke	
					XC	ZC
4.00	1 (Std.)	1.375	1.00	2.69	7.13	7.88
	2	2.500	1.63	3.31	7.75	8.50
	3	1.750	1.25	2.94	7.38	8.13
	4	2.000	1.38	3.06	7.50	8.25
	7	1.000	0.75	2.44	6.88	7.63
5.00	1 (Std.)	1.750	1.25	2.94	7.63	8.38
	2	3.500	1.63	3.31	8.00	8.75
	3	2.000	1.38	3.06	7.75	8.50
	4	2.500	1.63	3.31	8.00	8.75
	5	3.000	1.63	3.31	8.00	8.75
	7	1.000	0.75	2.44	7.13	7.88
	8	1.375	1.00	2.69	7.38	8.13

¹ NPTF ports will be furnished as standard unless SAE straight thread ports are specified.

² SAE straight thread ports are indicated by port number.

³ Cushion adjusting needle valve for 1.00" bore projects beyond sides of head and cap.

⁴ 1.00" bore 3L heads are rectangular — see 1.00" bore mounting information page.

⁵ On 1.00", 1.50", 2.00" and 2.50" bore sizes, the head end (only) pipe thread is not full depth on cylinders with No. 2 rods. Minimum of 3 full threads available.

⁶ Straight thread ports on 1.50" bore cap end, and head end with Code 2 rod, require an adapter fitting. Adapters are furnished as standard.

⁷ In 1.00" bore size only, a single fixed eye mounting lug, .44" thick is used. Dimension CD (.441") is hole diameter. Pin not furnished.

Mounting Information – 1.00" to 5.00" Bore Series 3L

Head Trunnion Mounting

Style D
(NFPA Style MT1)

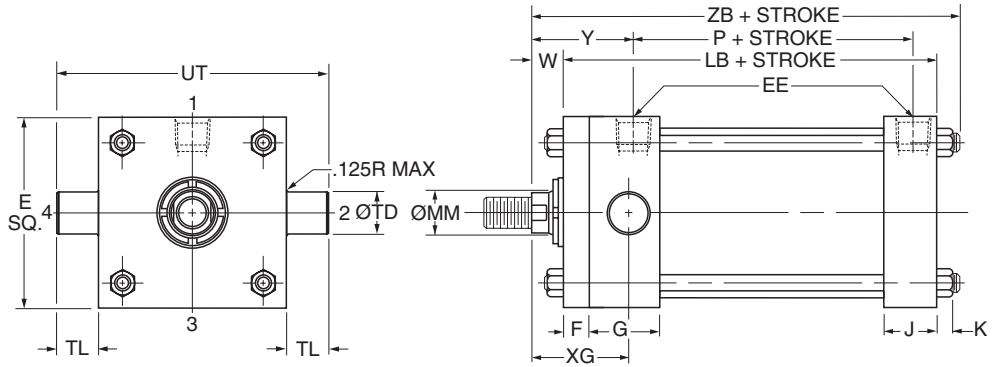
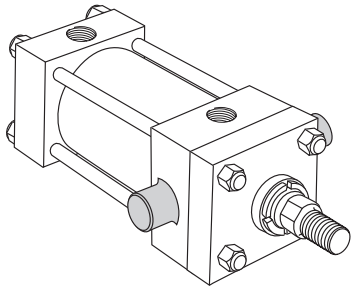

Table 1 – Dimensional and Mounting Data

Bore Ø	E	EE		F	G	J	K	TD Ø +.000 -.001	TL	UT	Add Stroke	
		NPTF ¹	SAE ²								LB	P
1.00 ³	4	1/4 ⁵	6	0.38	1.50	1.00	0.19	0.750	0.75	3.00	3.88	2.13
1.50	2.00	3/8 ⁵	6 ⁶	0.38	1.50	1.00	0.25	1.000	1.00	4.00	4.00	2.25
2.00	2.50	3/8 ⁵	6	0.38	1.50	1.00	0.31	1.000	1.00	4.50	4.00	2.25
2.50	3.00	3/8 ⁵	6	0.38	1.50	1.00	0.31	1.000	1.00	5.00	4.13	2.38
3.25	3.75	1/2	10	0.63	1.75	1.25	0.38	1.000	1.00	5.75	4.88	2.63
4.00	4.50	1/2	10	0.63	1.75	1.25	0.38	1.000	1.00	6.50	4.88	2.63
5.00	5.50	1/2	10	0.63	1.75	1.25	0.44	1.000	1.00	7.50	5.13	2.88

Table 2 – Dimensional and Mounting Data

Bore Ø	Rod No.	MM Rod Ø	W	XG	Y	Add Stroke
						ZB Max
1.00	1 (Std.)	0.500	0.63	1.75	1.94	5.00
	2	0.625	0.63	1.75	1.94	5.00
1.50	1 (Std.)	0.625	0.63	1.75	1.94	5.06
	2	1.000	1.00	2.13	2.31	5.44
2.00	1 (Std.)	0.625	0.63	1.75	1.94	5.13
	2	1.375	1.25	2.38	2.56	5.75
	3	1.000	1.00	2.13	2.31	5.50
2.50	1 (Std.)	1.000	1.00	2.13	2.31	5.63
	2	1.750	1.50	2.63	2.81	6.13
	3	1.375	1.25	2.38	2.56	5.88
	7	0.625	0.63	1.75	1.94	5.25
3.25	1 (Std.)	1.000	0.75	2.25	2.44	6.19
	2	2.000	1.38	2.88	3.06	6.81
	3	1.375	1.00	2.50	2.69	6.44
	4	1.750	1.25	2.75	2.94	6.69

Bore Ø	Rod No.	MM Rod Ø	W	XG	Y	Add Stroke
						ZB Max
4.00	1 (Std.)	1.375	1.00	2.50	2.69	6.44
	2	2.500	1.63	3.13	3.31	7.06
	3	1.750	1.25	2.75	2.94	6.69
	4	2.000	1.38	2.88	3.06	6.81
5.00	7	1.000	0.75	2.25	2.44	6.19
	1 (Std.)	1.750	1.25	2.75	2.94	7.06
	2	3.500	1.63	3.13	3.31	7.44
	3	2.000	1.38	2.88	3.06	7.31
	4	2.500	1.63	3.13	3.31	7.44
	5	3.000	1.63	3.13	3.31	7.44
	7	1.000	0.75	2.25	2.44	6.56
	8	1.375	1.00	2.50	2.69	6.81

¹ NPTF ports will be furnished as standard unless SAE straight thread ports are specified.

² SAE straight thread ports are indicated by port number.

³ Cushion adjusting needle valve for 1.00" bore projects beyond sides of head and cap.

⁴ 1.00" bore 3L heads are rectangular — see 1.00" bore mounting information page.

⁵ On 1.00", 1.50", 2.00" and 2.50" bore sizes, the head end (only) pipe thread is not full depth on cylinders with No. 2 rods. Minimum of 3 full threads available.

⁶ Straight thread ports on 1.50" bore cap end, and head end with Code 2 rod, require an adapter fitting. Adapters are furnished as standard.



Mounting Information – 1.00" to 5.00" Bore Series 3L

Cap Trunnion Mounting
Style DB
(NFPA Style MT2)

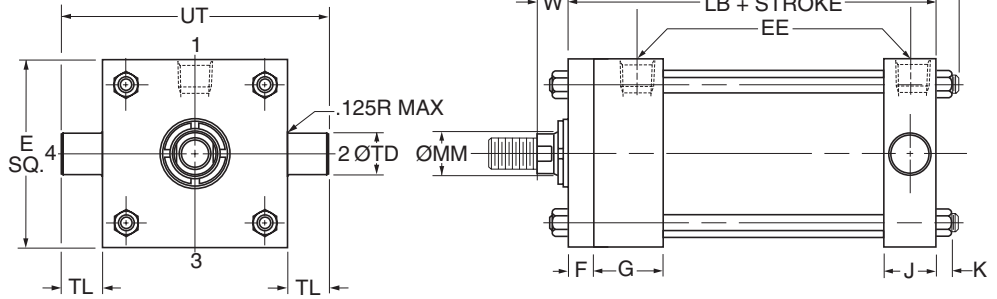
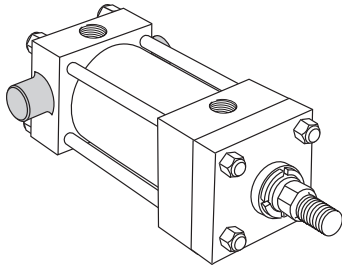

Table 1 – Dimensional and Mounting Data

Bore Ø	E	EE		F	G	J	K	TD Ø +.000 -.001	TL	UT	Add Stroke	
		NPTF ¹	SAE ²								LB	P
1.00 ³	4	1/4 ⁵	6	0.38	1.50	1.00	0.19	0.750	0.75	3.00	3.88	2.13
1.50	2.00	3/8 ⁵	6 ⁶	0.38	1.50	1.00	0.25	1.000	1.00	4.00	4.00	2.25
2.00	2.50	3/8 ⁵	6	0.38	1.50	1.00	0.31	1.000	1.00	4.50	4.00	2.25
2.50	3.00	3/8 ⁵	6	0.38	1.50	1.00	0.31	1.000	1.00	5.00	4.13	2.38
3.25	3.75	1/2	10	0.63	1.75	1.25	0.38	1.000	1.00	5.75	4.88	2.63
4.00	4.50	1/2	10	0.63	1.75	1.25	0.38	1.000	1.00	6.50	4.88	2.63
5.00	5.50	1/2	10	0.63	1.75	1.25	0.44	1.000	1.00	7.50	5.13	2.88

Table 2 – Dimensional and Mounting Data

Bore Ø	Rod No.	MM Rod Ø	W	Y	Add Stroke	
					XJ	ZB Max
1.00	1 (Std.)	0.500	0.63	1.94	4.00	5.00
	2	0.625	0.63	1.94	4.00	5.00
1.50	1 (Std.)	0.625	0.63	1.94	4.13	5.06
	2	1.000	1.00	2.31	4.50	5.44
2.00	1 (Std.)	0.625	0.63	1.94	4.13	5.13
	2	1.375	1.25	2.56	4.75	5.75
	3	1.000	1.00	2.31	4.50	5.50
2.50	1 (Std.)	1.000	1.00	2.31	4.63	5.63
	2	1.750	1.50	2.81	5.13	6.13
	3	1.375	1.25	2.56	4.88	5.88
	7	0.625	0.63	1.94	4.25	5.25
3.25	1 (Std.)	1.000	0.75	2.44	5.00	6.19
	2	2.000	1.38	3.06	5.63	6.81
	3	1.375	1.00	2.69	5.25	6.44
	4	1.750	1.25	2.94	5.50	6.69

Bore Ø	Rod No.	MM Rod Ø	W	Y	Add Stroke	
					XJ	ZB Max
4.00	1 (Std.)	1.375	1.00	2.69	5.25	6.44
	2	2.500	1.63	3.31	5.88	7.06
	3	1.750	1.25	2.94	5.50	6.69
	4	2.000	1.38	3.06	5.63	6.81
5.00	7	1.000	0.75	2.44	5.00	6.19
	1 (Std.)	1.750	1.25	2.94	5.75	7.06
	2	3.500	1.63	3.31	6.13	7.44
	3	2.000	1.38	3.06	5.88	7.31
	4	2.500	1.63	3.31	6.13	7.44
	5	3.000	1.63	3.31	6.13	7.44
	7	1.000	0.75	2.44	5.25	6.56
	8	1.375	1.00	2.69	5.50	6.81

¹ NPTF ports will be furnished as standard unless SAE straight thread ports are specified.

² SAE straight thread ports are indicated by port number.

³ Cushion adjusting needle valve for 1.00" bore projects beyond sides of head and cap.

⁴ 1.00" bore 3L heads are rectangular — see 1.00" bore mounting information page.

⁵ On 1.00", 1.50", 2.00" and 2.50" bore sizes, the head end (only) pipe thread is not full depth on cylinders with No. 2 rods. Minimum of 3 full threads available.

⁶ Straight thread ports on 1.50" bore cap end, and head end with Code 2 rod, require an adapter fitting. Adapters are furnished as standard.

Mounting Information – 1.50" to 5.00" Bore Series 3L

Intermediate Fixed Trunnion Mounting

Style DD⁶
(NFPA Style MT4)

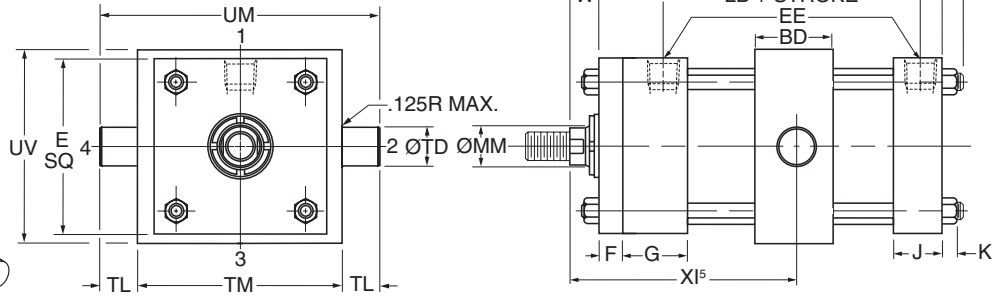
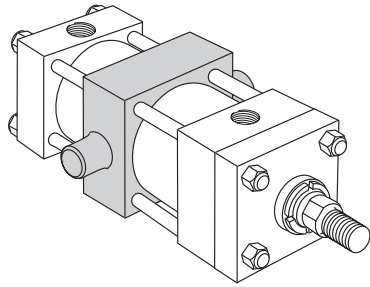

Table 1 – Dimensional and Mounting Data

Bore Ø	E	BD	EE		F	G	J	K	TD Ø +.000 -.001	TL	TM	UM	UV	Add Stroke	
			NPTF ¹	SAE ²										LB	P
1.50	2.00	1.25	3/8 ³	6 ⁴	0.38	1.50	1.00	0.25	1.000	1.00	2.50	4.50	2.50	4.00	2.25
2.00	2.50	1.50	3/8 ³	6	0.38	1.50	1.00	0.31	1.000	1.00	3.00	5.00	3.00	4.00	2.25
2.50	3.00	1.50	3/8 ³	6	0.38	1.50	1.00	0.31	1.000	1.00	3.50	5.50	3.50	4.13	2.38
3.25	3.75	2.00	1/2	10	0.63	1.75	1.25	0.38	1.000	1.00	4.50	6.50	4.25	4.88	2.63
4.00	4.50	2.00	1/2	10	0.63	1.75	1.25	0.38	1.000	1.00	5.25	7.25	5.00	4.88	2.63
5.00	5.50	2.00	1/2	10	0.63	1.75	1.25	0.44	1.000	1.00	6.25	8.25	6.00	5.13	2.88

Table 2 – Dimensional and Mounting Data

Bore Ø	Rod No.	MM Rod Ø	W	XI ⁵ Min.	Min. Stroke	Y	Add Stroke
							ZB Max
1.50	1 (Std.)	0.625	0.63	3.19	0.25	1.94	5.06
	2	1.000	1.00	3.56	0.25	2.31	5.44
2.00	1 (Std.)	0.625	0.63	3.31	0.50	1.94	5.13
	2	1.375	1.25	3.94	0.50	2.56	5.75
	3	1.000	1.00	3.69	0.50	2.31	5.50
2.50	1 (Std.)	1.000	1.00	3.69	0.38	2.31	5.63
	2	1.750	1.50	4.19	0.38	2.81	6.13
	3	1.375	1.25	3.94	0.38	2.56	5.88
	7	0.625	0.63	3.31	0.38	1.94	5.25
3.25	1 (Std.)	1.000	0.75	4.19	0.88	2.44	6.19
	2	2.000	1.38	4.81	0.88	3.06	6.81
	3	1.375	1.00	4.44	0.88	2.69	6.44
	4	1.750	1.25	4.69	0.88	2.94	6.69

Bore Ø	Rod No.	MM Rod Ø	W	XI ⁵ Min.	Min. Stroke	Y	Add Stroke
							ZB Max
4.00	1 (Std.)	1.375	1.00	4.44	0.88	2.69	6.44
	2	2.500	1.63	5.06	0.88	3.31	7.06
	3	1.750	1.25	4.69	0.88	2.94	6.69
	4	2.000	1.38	4.81	0.88	3.06	6.81
	7	1.000	0.75	4.19	0.88	2.44	6.19
5.00	1 (Std.)	1.750	1.25	4.69	0.63	2.94	7.06
	2	3.500	1.63	5.06	0.63	3.31	7.44
	3	2.000	1.38	4.81	0.63	3.06	7.31
	4	2.500	1.63	5.06	0.63	3.31	7.44
	5	3.000	1.63	5.06	0.63	3.31	7.44
	7	1.000	0.75	4.19	0.63	2.44	6.56
	8	1.375	1.00	4.44	0.63	2.69	6.81

¹ NPTF ports will be furnished as standard unless SAE straight thread ports are specified.

² SAE straight thread ports are indicated by port number.

³ On 1.50", 2.00" and 2.50" bore sizes, the head end (only) pipe thread is not full depth on cylinders with No. 2 rods. Minimum of 3 full threads available.

⁴ Straight thread ports on 1.50" bore cap end, and head end with Code 2 rod, require an adapter fitting. Adapters are furnished as standard.

⁵ Dimension XI to be specified by customer.

⁶ Mounting style DD not available in 1.00" bore.



Mounting Information – 1.50" to 5.00" Bore Series 3L

Spherical Bearing Mounting
Style SB

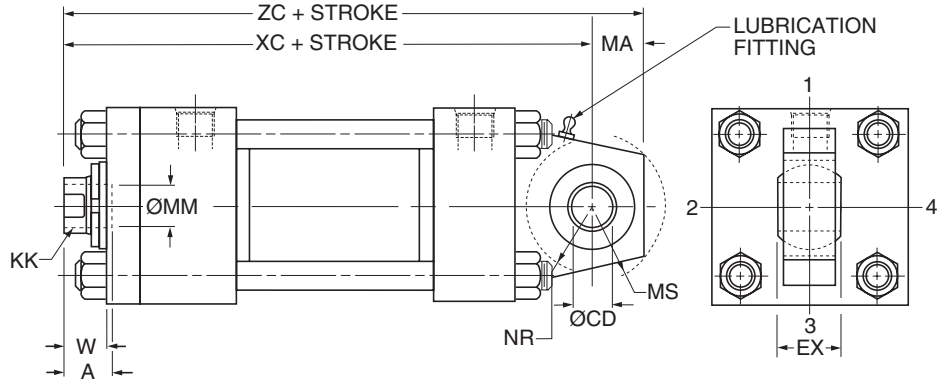

Table 1 – Dimensional and Mounting Data

Bore Ø	Rod No.	MM Rod Ø	Thread Style 7 KK ¹	Thread Style 9 KK ¹	A	CD ² Ø	EX	MA	MS	NR	W	Add Stroke		Max. Oper. PSI ³	
												XC	ZC		
1.50	1 (Std)	0.625	–	7/16-20	0.75	-.0005 .5000	0.44	0.75	0.94	0.63	0.63	5.38	6.13	1500	
	2	1.000	7/16-20	–	0.75							1.00	5.75		6.50
2.00	1 (Std)	0.625	–	7/16-20	0.75	-.0005 .5000	0.44	0.75	0.94	0.63	0.63	5.38	6.13	980	
	2	1.375	7/16-20	–	0.75							1.25	6.00		6.75
	3	1.000		–	0.75							1.00	5.75		6.50
2.50	1 (Std)	0.625	–	7/16-20	0.75	-.0005 .5000	0.44	0.75	0.94	0.63	0.63	5.50	6.25	630	
	2	1.750	7/16-20	–	0.75							1.50	6.38		7.13
	3	1.000		–	0.75							1.00	5.88		6.63
	4	1.375		–	0.75							1.25	6.13		6.88
3.25	1 (Std)	1.000	–	3/4-16	1.13	-.0005 .7500	0.66	1.00	1.38	1.00	0.75	6.88	7.88	830	
	2	2.000	3/4-16	–	1.13							1.38	7.50		8.50
	3	1.375		–	1.13							1.00	7.13		8.13
	4	1.750		–	1.13							1.25	7.38		8.38
4.00	1 (Std)	1.000	–	3/4-16	1.13	-.0005 .7500	0.66	1.00	1.38	1.00	0.75	6.88	7.88	550	
	2	2.500	3/4-16	–	1.13							1.63	7.75		8.75
	3	1.375		–	1.13							1.00	7.13		8.13
	4	1.750		–	1.13							1.25	7.38		8.38
	5	2.000		–	1.13							1.38	7.50		8.50
5.00	1 (Std)	1.000	–	3/4-16	1.13	-.0005 .7500	0.66	1.00	1.38	1.00	0.75	7.13	8.13	350	
	2	3.500	3/4-16	–	1.13							1.63	8.00		9.00
	3	1.375		–	1.13							1.00	7.38		8.38
	4	1.750		–	1.13							1.25	7.63		8.63
	5	2.000		–	1.13							1.38	7.75		8.75
	6	2.500		–	1.13							1.63	8.00		9.00
	7	3.000		–	1.13							1.63	8.00		9.00

¹ Threads listed are also for a spherical rod eye which match style 9 or style 7. The spherical rod eye pin diameter matches the cap pin and (if required) needs to be purchased separately. See 3L Mounting Accessories for detailed information.

² Dimension CD is hole diameter.

³ Maximum operating pressure at 4:1 design factor is based on tensile strength of material.

Note: For additional dimensions, see Series 3L Style BB Mount.



Rod End Dimensions

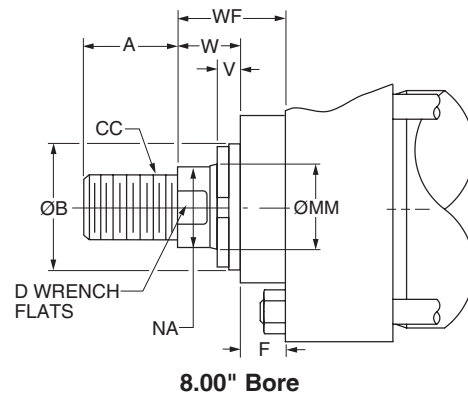
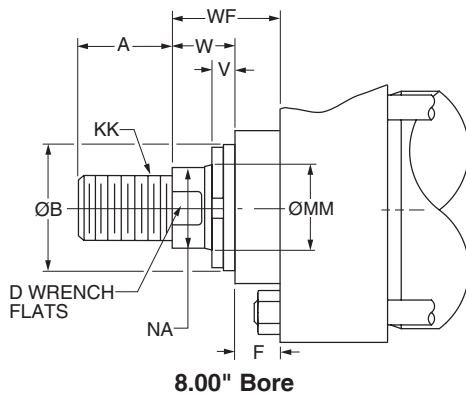
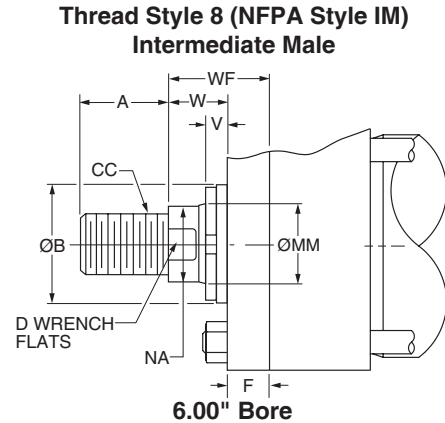
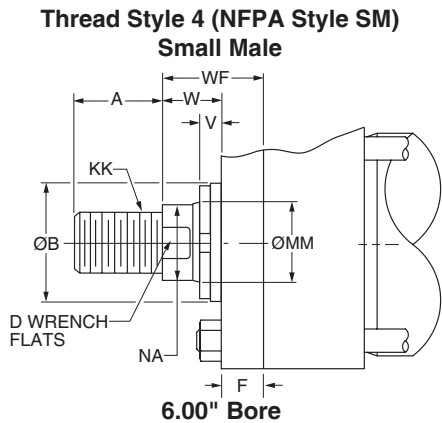

Rod End Dimensions

Bore Ø	Rod No.	MM Rod Ø	Thread		A	B Ø +0.000 -0.002	D	F	NA	V	W	WF
			Style 8 CC	Style 4 KK								
6.00	1 (Std.)	1.750	1 1/2-12	1 1/4-12	2.00	2.374	1.50	0.75	1.69	0.38	1.13	1.88
	2	4.000	3 3/4-12	3-12	4.00	4.749	3.38	0.75	3.88	0.50	1.50	2.25
	3	2.000	1 3/4-12	1 1/2-12	2.25	2.624	1.69	0.75	1.94	0.38	1.25	2.00
	4	2.500	2 1/4-12	1 7/8-12	3.00	3.124	2.06	0.75	2.38	0.50	1.50	2.25
	5	3.000	2 3/4-12	2 1/4-12	3.50	3.749	2.63	0.75	2.88	0.50	1.50	2.25
	6	3.500	3 1/4-12	2 1/2-12	3.50	4.249	3.00	0.75	3.38	0.50	1.50	2.25
	7	1.375	1 1/4-12	1-14	1.63	1.999	1.13	0.75	1.31	0.25	0.88	1.63
8.00	1 (Std.)	2.000	1 3/4-12	1 1/2-12	2.25	2.624	1.69	0.75	1.94	0.38	1.25	2.00
	2	5.500	5 1/4-12	4-12	5.50	6.249	- ¹	0.75	5.38	0.50	1.50	2.25
	3	2.500	2 1/4-12	1 7/8-12	3.00	3.124	2.06	0.75	2.38	0.50	1.50	2.25
	4	3.000	2 3/4-12	2 1/4-12	3.50	3.749	2.63	0.75	2.88	0.50	1.50	2.25
	5	3.500	3 1/4-12	2 1/2-12	3.50	4.249	3.00	0.75	3.38	0.50	1.50	2.25
	6	4.000	3 3/4-12	3-12	4.00	4.749	3.38	0.75	3.88	0.50	1.50	2.25
	7	1.375	1 1/4-12	1-14	1.63	1.999	1.13	0.75	1.31	0.25	0.88	1.63
	8	1.750	1 1/2-12	1 1/4-12	2.00	2.374	1.50	0.75	1.69	0.38	1.13	1.88
	9	4.500	4 1/4-12	3 1/4-12	4.50	5.249	- ¹	0.75	4.38	0.50	1.50	2.25
	0	5.000	4 3/4-12	3 1/2-12	5.00	5.749	- ¹	0.75	4.88	0.50	1.50	2.25

"Special" Thread Style 3

Special thread, extension, rod eye, blank, etc., are also available.

To order, specify "Style 3" and give desired dimensions for KK, A, W or WF. If otherwise special, furnish dimensioned sketch.

¹ These piston rod numbers will have 4 spanner wrench holes (.515 Dia. X .75 Deep) instead of wrench flats.



Rod End Dimensions

**Thread Style 9² (NFPA Style SF)
Small Female**

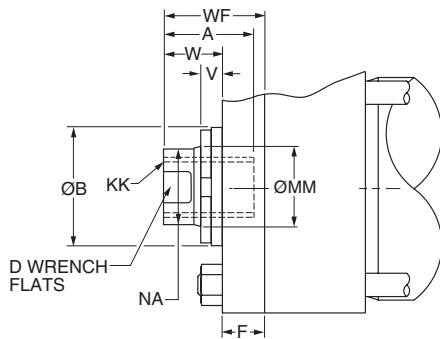

6.00" Bore

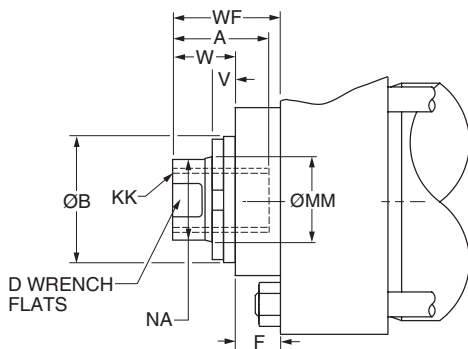

8.00" Bore

**Style 55¹
Flanged Rod End**

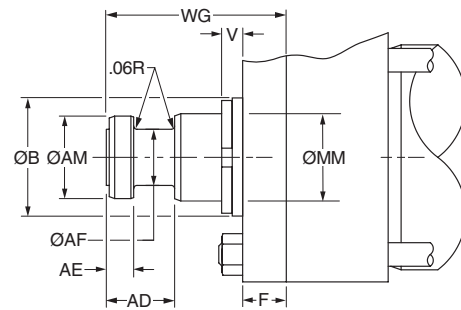

6.00" Bore

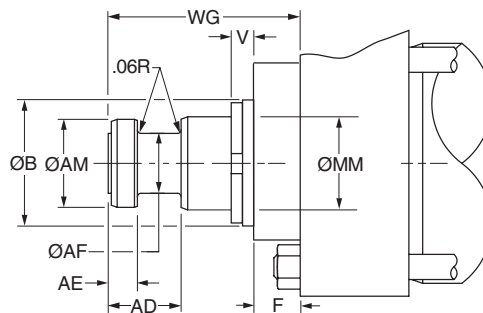

8.00" Bore

Rod End Dimensions

Bore Ø	Rod No.	MM Rod Ø	Thread	A	AD	AE +.001 -.001	AF	AM	B Ø +.000 -.002	D	F	NA	V	W	WF	WG
			Style 9													
6.00	1 (Std.)	1.750	1 1/4-12	2.00	1.31	0.50	1.13	1.70	2.374	1.50	0.75	1.69	0.38	1.13	1.88	3.13
	2	4.000	3-12	4.00	2.69	1.00	3.00	3.95	4.749	3.38	0.75	3.88	0.50	1.50	2.25	5.75
	3	2.000	1 1/2-12	2.25	1.69	0.63	1.38	1.95	2.624	1.69	0.75	1.94	0.38	1.25	2.00	3.75
	4	2.500	1 7/8-12	3.00	1.94	0.75	1.75	2.45	3.124	2.06	0.75	2.38	0.50	1.50	2.25	4.50
	5	3.000	2 1/4-12	3.50	2.44	0.88	2.25	2.95	3.749	2.63	0.75	2.88	0.50	1.50	2.25	4.88
	6	3.500	2 1/2-12	3.50	2.69	1.00	2.50	3.45	4.249	3.00	0.75	3.38	0.50	1.50	2.25	5.63
	7	1.375	1-14	1.63	1.06	0.38	0.88	1.32	1.999	1.13	0.75	1.31	0.25	0.88	1.63	2.75
8.00	1 (Std.)	2.000	1 1/2-12	2.25	1.69	0.63	1.38	1.95	2.624	1.69	0.75	1.94	0.38	1.25	2.00	3.75
	2	5.500	4-12	5.50	3.94	1.88	4.38	5.45	6.249	- ³	0.75	5.38	0.50	1.50	2.25	7.50
	3	2.500	1 7/8-12	3.00	1.94	0.75	1.75	2.45	3.124	2.06	0.75	2.38	0.50	1.50	2.25	4.50
	4	3.000	2 1/4-12	3.50	2.44	0.88	2.25	2.95	3.749	2.63	0.75	2.88	0.50	1.50	2.25	4.88
	5	3.500	2 1/2-12	3.50	2.69	1.00	2.50	3.45	4.249	3.00	0.75	3.38	0.50	1.50	2.25	5.63
	6	4.000	3-12	4.00	2.69	1.00	3.00	3.95	4.749	3.38	0.75	3.88	0.50	1.50	2.25	5.75
	7	1.375	1-14	1.63	1.06	0.38	0.88	1.32	1.999	1.13	0.75	1.31	0.25	0.88	1.63	2.75
	8	1.750	1 1/4-12	2.00	1.31	0.50	1.13	1.70	2.374	1.50	0.75	1.69	0.38	1.13	1.88	3.13
	9	4.500	3 1/4-12	4.50	3.19	1.50	3.50	4.45	5.249	- ³	0.75	4.38	0.50	1.50	2.25	6.50
	0	5.000	3 1/2-12	5.00	3.19	1.50	3.88	4.95	5.749	- ³	0.75	4.88	0.50	1.50	2.25	6.63

“Special” Thread Style 3

Special thread, extension, rod eye, blank, etc., are also available.

To order, specify “Style 3” and give desired dimensions for KK, A, W or WF. If otherwise special, furnish dimensioned sketch.

¹ For special WG dimension, specify “Style 3” and give desired dimension for WG. For other changes, place “S” in the model code, and describe rod end with dimensioned sketch.

² Style 9 stroke restrictions may apply. See Style 9 Minimum Stroke Table on How to Order page for details.

³ These piston rod numbers will have 4 spanner wrench holes (.515 Dia. X .75 Deep) instead of wrench flats.



Tie Rods Extended Both Ends Mounting

Style TD
(NFFPA Style MX3)

6.00" Bore

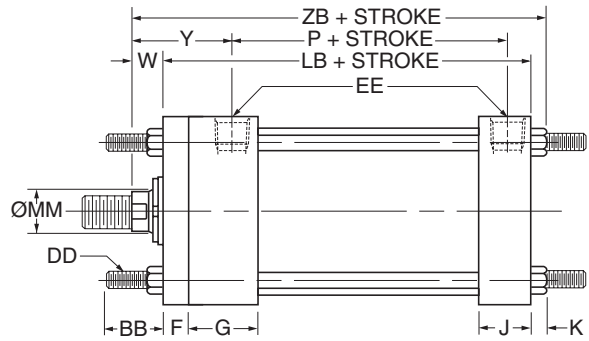
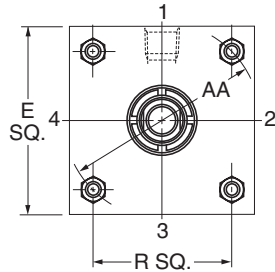
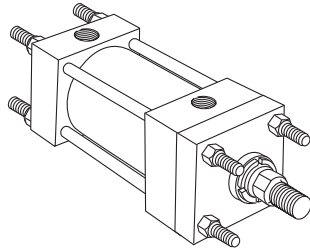

8.00" Bore

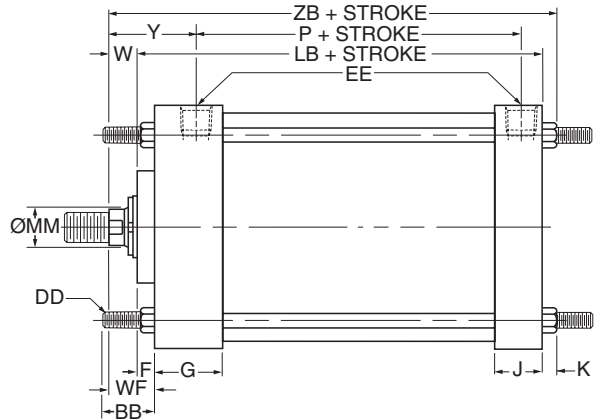
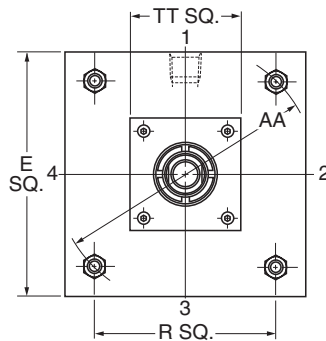
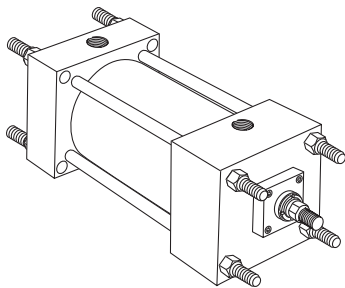

Table 1 – Dimensional and Mounting Data

Bore Ø	AA	BB	DD	E	EE		F	G	J	K	R	Add Stroke	
					NPTF ¹	SAE ²						LB	P
6.00	6.90	1.81	1/2-20	6.50	3/4	12	0.75	2.00	1.50	0.44	4.88	5.75	3.13
8.00	9.10	2.31	5/8-18	8.50	3/4	12	0.75	2.00	1.50	0.56	6.44	5.88	3.25

¹ NPTF Ports will be furnished as standard unless SAE Straight Thread Ports are specified.

² SAE straight thread ports are indicated by port number.

Table 2 – Dimensional and Mounting Data

Bore Ø	Rod No.	MM Rod Ø	TT	W	WF	Y	Add Stroke
							ZB Max
6.00	1 (Std.)	1.750	–	1.13	–	3.06	7.56
	2	4.000	–	1.50	–	3.44	7.94
	3	2.000	–	1.25	–	3.19	7.69
	4	2.500	–	1.50	–	3.44	7.44
	5	3.000	–	1.50	–	3.44	7.44
	6	3.500	–	1.50	–	3.44	7.44
	7	1.375	–	0.88	–	2.81	7.31
8.00	1 (Std.)	2.000	4.00	1.25	2.00	3.19	7.94
	2	5.500	7.00	1.50	2.25	3.44	8.19
	3	2.500	4.00	1.50	2.25	3.44	8.19
	4	3.000	5.50	1.50	2.25	3.44	8.19
	5	3.500	5.50	1.50	2.25	3.44	8.19
	6	4.000	5.50	1.50	2.25	3.44	8.19
	7	1.375	4.00	0.88	1.63	2.81	7.56
	8	1.750	4.00	1.13	1.88	3.06	7.81
	9	4.500	7.00	1.50	2.25	3.44	8.19
	0	5.000	7.00	1.50	2.25	3.44	8.19

Style TB

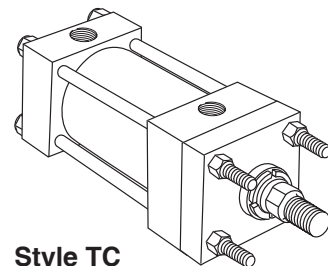

Style TC

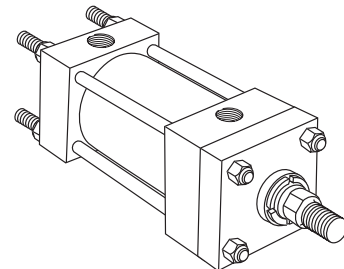

Style TD (NFFPA MX3) Both Ends Tie Rods Extended, illustrated: Style TC (NFFPA MX2), Cap Tie Rods Extended; and Style TB (NFFPA MX1), Head Tie Rods Extended are also available.

Basic Mounting (T) — NFFPA MX0 — no tie rods extended can be supplied upon request.

Head Square Flange Mounting
Style JB

6.00" Bore (NFFPA Style MF5)

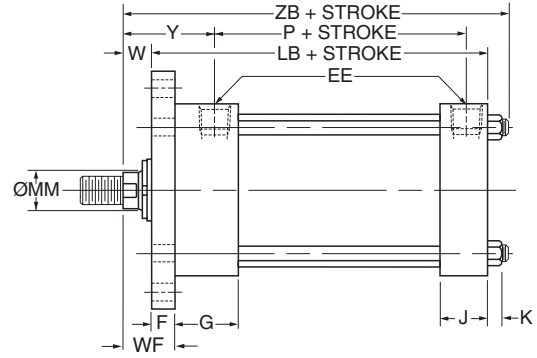
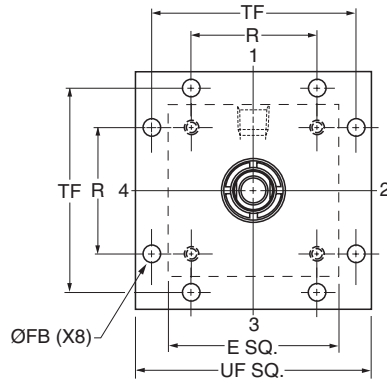
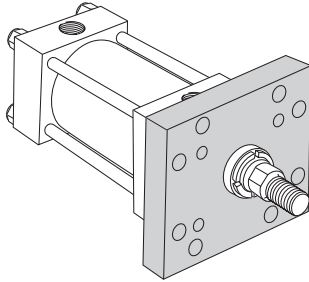

8.00" Bore (NFFPA Style ME3)

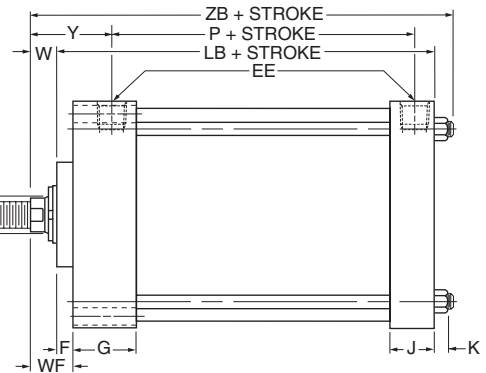
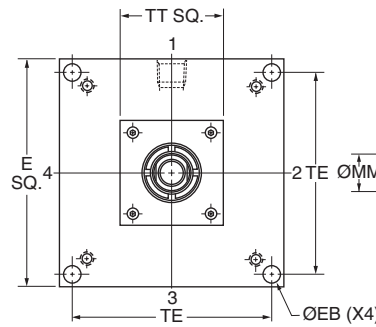
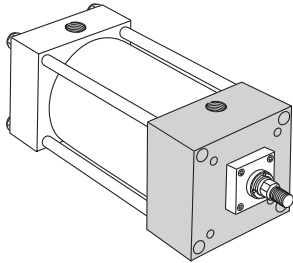

Table 1 – Dimensional and Mounting Data

Bore Ø	E	EB Ø	EE		F	FB Ø	G	J	K	R	TE	TF	UF	Add Stroke	
			NPTF ¹	SAE ²										LB	P
6.00	6.50	–	3/4	12	0.75	0.56	2.00	1.50	0.44	4.88	–	7.63	8.63	5.75	3.13
8.00	8.50	0.69	3/4	12	0.75	0.56	2.00	1.50	0.56	–	7.57	–	–	5.88	3.25

¹ NPTF Ports will be furnished as standard unless SAE Straight Thread Ports are specified.

² SAE straight thread ports are indicated by port number.

Table 2 – Dimensional and Mounting Data

Bore Ø	Rod No.	MM Rod Ø	TT	W	WF	Y	Add Stroke
							ZB Max.
6.00	1 (Std.)	1.750	–	1.13	1.88	3.06	7.56
	2	4.000	–	1.50	2.25	3.44	7.94
	3	2.000	–	1.25	2.00	3.19	7.69
	4	2.500	–	1.50	2.25	3.44	7.44
	5	3.000	–	1.50	2.25	3.44	7.44
	6	3.500	–	1.50	2.25	3.44	7.44
	7	1.375	–	0.88	1.63	2.81	7.31
8.00	1 (Std.)	2.000	4.00	1.25	2.00	3.19	7.94
	2	5.500	7.00	1.50	2.25	3.44	8.19
	3	2.500	4.00	1.50	2.25	3.44	8.19
	4	3.000	5.50	1.50	2.25	3.44	8.19
	5	3.500	5.50	1.50	2.25	3.44	8.19
	6	4.000	5.50	1.50	2.25	3.44	8.19
	7	1.375	4.00	0.88	1.63	2.81	7.56
	8	1.750	4.00	1.13	1.88	3.06	7.81
	9	4.500	7.00	1.50	2.25	3.44	8.19
	0	5.000	7.00	1.50	2.25	3.44	8.19



Mounting Information – 6.00" & 8.00" Bore Series 3L

Cap Square Flange Mounting Style HB

6.00" Bore (NFFPA Style MF6)

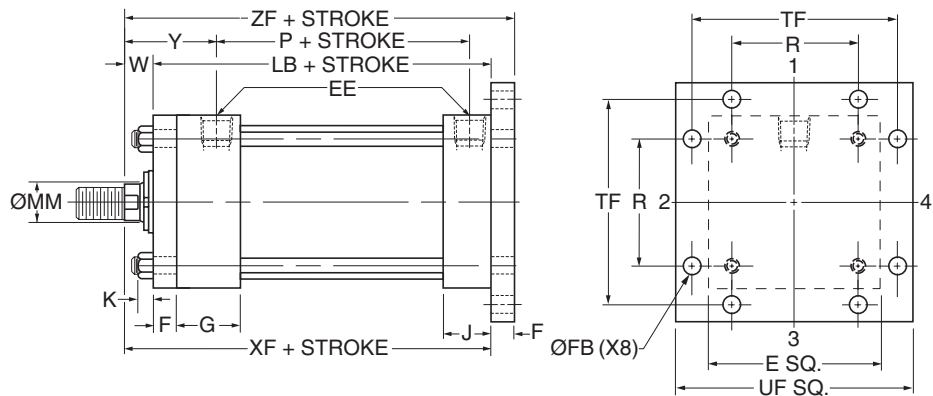
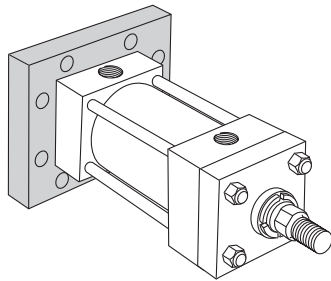

8.00" Bore (NFFPA Style ME4)

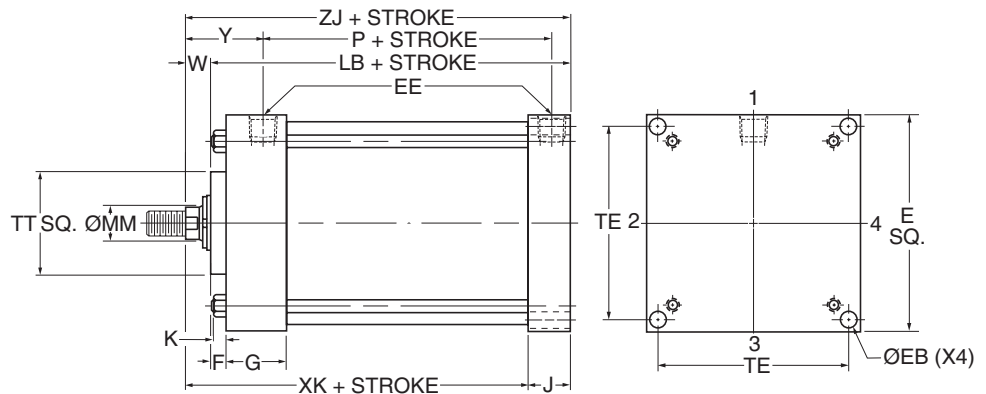
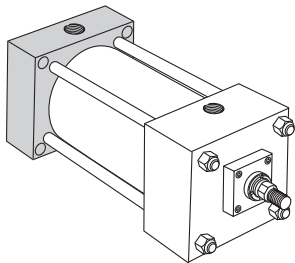

Table 1 – Dimensional and Mounting Data

Bore Ø	E	EB Ø	EE		F	FB Ø	G	J	K	R	TE	TF	UF	Add Stroke	
			NPTF ¹	SAE ²										LB	P
6.00	6.50	–	3/4	12	0.75	0.56	2.00	1.50	0.44	4.88	–	7.63	8.63	5.75	3.13
8.00	8.50	0.69	3/4	12	0.75	–	2.00	1.50	0.56	–	7.57	–	–	5.88	3.25

¹ NPTF Ports will be furnished as standard unless SAE Straight Thread Ports are specified.

² SAE straight thread ports are indicated by port number.

Table 2 – Dimensional and Mounting Data

Bore Ø	Rod No.	MM Rod Ø	TT	W	Y	Add Stroke			
						XF	XK	ZF	ZJ
6.00	1 (Std.)	1.750	–	1.13	3.06	6.88	–	7.63	–
	2	4.000	–	1.50	3.44	7.25	–	8.00	–
	3	2.000	–	1.25	3.19	7.00	–	7.75	–
	4	2.500	–	1.50	3.44	7.25	–	8.00	–
	5	3.000	–	1.50	3.44	7.25	–	8.00	–
	6	3.500	–	1.50	3.44	7.25	–	8.00	–
	7	1.375	–	0.88	2.81	6.63	–	7.38	–
8.00	1 (Std.)	2.000	4.00	1.25	3.19	–	5.63	–	7.13
	2	5.500	7.00	1.50	3.44	–	5.88	–	7.38
	3	2.500	4.00	1.50	3.44	–	5.88	–	7.38
	4	3.000	5.50	1.50	3.44	–	5.88	–	7.38
	5	3.500	5.50	1.50	3.44	–	5.88	–	7.38
	6	4.000	5.50	1.50	3.44	–	5.88	–	7.38
	7	1.375	4.00	0.88	2.81	–	5.25	–	6.75
	8	1.750	4.00	1.13	3.06	–	5.50	–	7.00
	9	4.500	7.00	1.50	3.44	–	5.88	–	7.38
	0	5.000	7.00	1.50	3.44	–	5.88	–	7.38



Side Lug Mounting

Style C

(NFPA Style MS2)

6" Bore

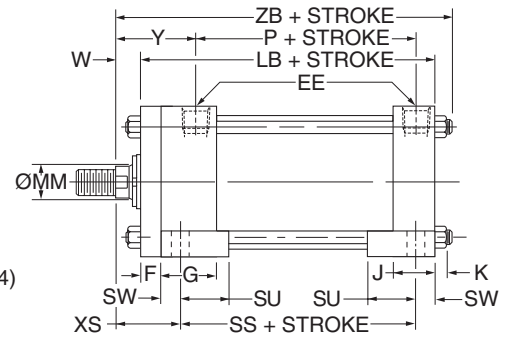
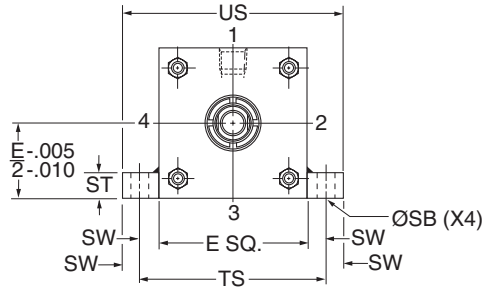
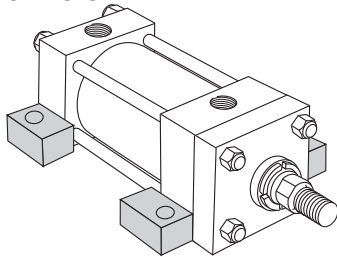

8" Bore

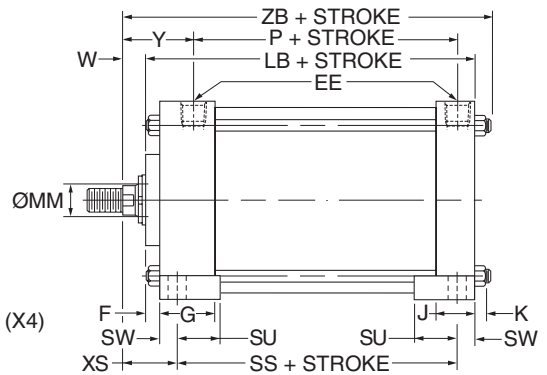
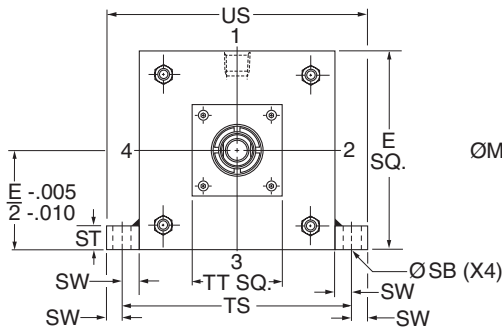
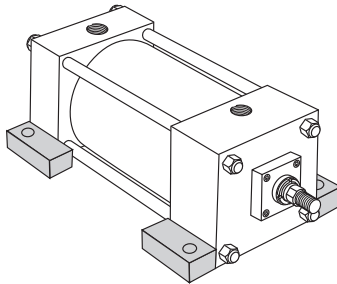

Table 1 – Dimensional and Mounting Data

Bore Ø	E	EE		F	G	J	K	SB Ø	ST	SU	SW	TS	US	Add Stroke		
		NPTF ¹	SAE ²											LB	P	SS
6.00	6.50	3/4	12	0.75	2.00	1.50	0.44	0.81	1.00	1.56	0.69	7.88	9.25	5.75	3.13	3.63
8.00	8.50	3/4	12	0.75	2.00	1.50	0.56	0.81	1.00	1.56	0.69	9.88	11.25	5.88	3.25	3.75

¹ NPTF Ports will be furnished as standard unless SAE Straight Thread Ports are specified.

² SAE straight thread ports are indicated by port number.

Table 2 – Dimensional and Mounting Data

Bore Ø	Rod No.	MM Rod Ø	TT	W	XS	Y	Add Stroke
							ZB Max.
6.00	1 (Std.)	1.750	–	1.13	2.56	3.06	7.56
	2	4.000	–	1.50	2.94	3.44	7.94
	3	2.000	–	1.25	2.69	3.19	7.69
	4	2.500	–	1.50	2.94	3.44	7.44
	5	3.000	–	1.50	2.94	3.44	7.44
	6	3.500	–	1.50	2.94	3.44	7.44
	7	1.375	–	0.88	2.56	2.81	7.31
8.00	1 (Std.)	2.000	4.00	1.25	2.69	3.19	7.94
	2	5.500	7.00	1.50	2.94	3.44	8.19
	3	2.500	4.00	1.50	2.94	3.44	8.19
	4	3.000	5.50	1.50	2.94	3.44	8.19
	5	3.500	5.50	1.50	2.94	3.44	8.19
	6	4.000	5.50	1.50	2.94	3.44	8.19
	7	1.375	4.00	0.88	2.31	2.81	7.56
	8	1.750	4.00	1.13	2.56	3.06	7.81
	9	4.500	7.00	1.50	2.94	3.44	8.19
	0	5.000	7.00	1.50	2.94	3.44	8.19



Side Tapped Mounting

Style F
(NFPA Style MS4)

6.00" Bore

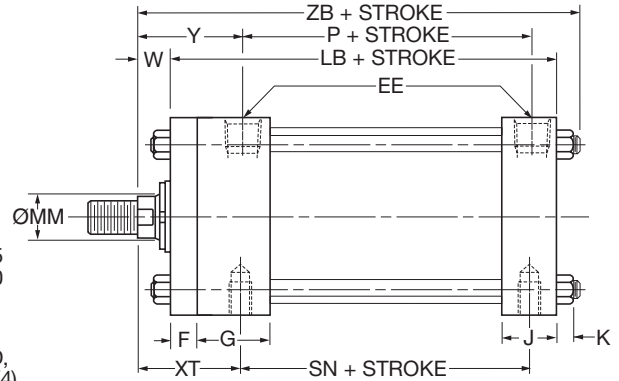
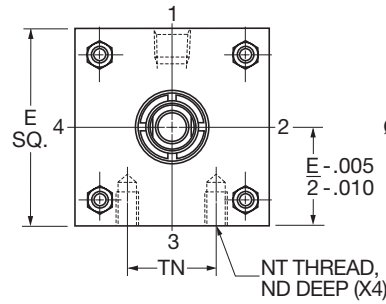
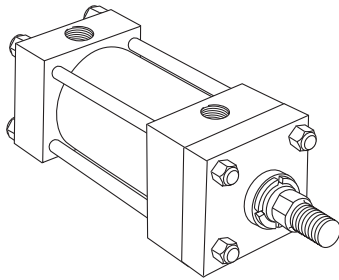

8.00" Bore

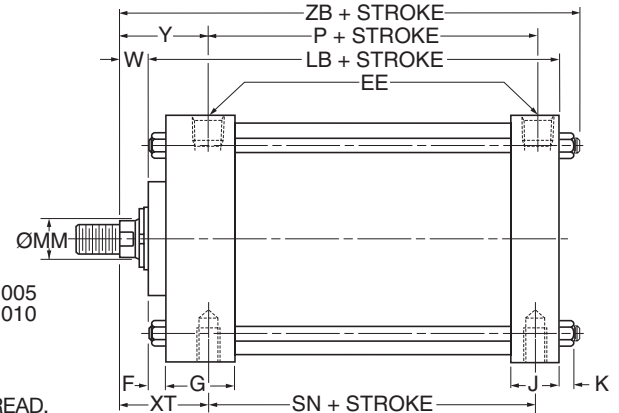
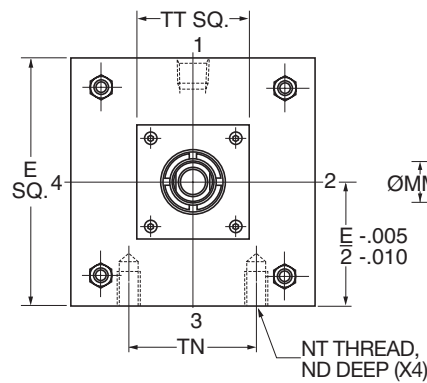
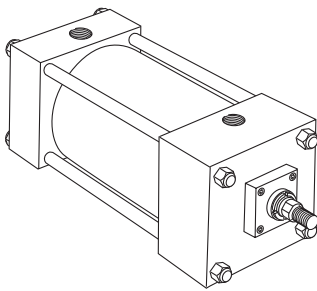

Table 1 – Dimensional and Mounting Data

Bore Ø	E	EE		F	G	J	K	ND	NT	TN	Add Stroke		
		NPTF ¹	SAE ²								LB	P	SN
6.00	6.50	3/4	12	0.75	2.00	1.50	0.44	0.88	3/4-10	3.25	5.75	3.13	3.13
8.00	8.50	3/4	12	0.75	2.00	1.50	0.56	1.13	3/4-10	4.50	5.88	3.25	3.25

¹ NPTF ports will be furnished as standard unless SAE straight thread ports are specified.

² SAE straight thread ports are indicated by port number.

Table 2 – Dimensional and Mounting Data

Bore Ø	Rod No.	MM Rod Ø	TT	W	XT	Y	Add Stroke
							ZB Max.
6.00	1 (Std.)	1.750	–	1.13	3.06	3.06	7.56
	2	4.000	–	1.50	3.44	3.44	7.94
	3	2.000	–	1.25	3.19	3.19	7.69
	4	2.500	–	1.50	3.44	3.44	7.44
	5	3.000	–	1.50	3.44	3.44	7.44
	6	3.500	–	1.50	3.44	3.44	7.44
	7	1.375	–	0.88	2.81	2.81	7.31
8.00	1 (Std.)	2.000	4.00	1.25	3.19	3.19	7.94
	2	5.500	7.00	1.50	3.44	3.44	8.19
	3	2.500	4.00	1.50	3.44	3.44	8.19
	4	3.000	5.50	1.50	3.44	3.44	8.19
	5	3.500	5.50	1.50	3.44	3.44	8.19
	6	4.000	5.50	1.50	3.44	3.44	8.19
	7	1.375	4.00	0.88	2.81	2.81	7.56
	8	1.750	4.00	1.13	3.06	3.06	7.81
	9	4.500	7.00	1.50	3.44	3.44	8.19
0	5.000	7.00	1.50	3.44	3.44	8.19	



Cap Fixed Clevis Mounting

Style BB
(NFPA Style MP1)

6.00" Bore

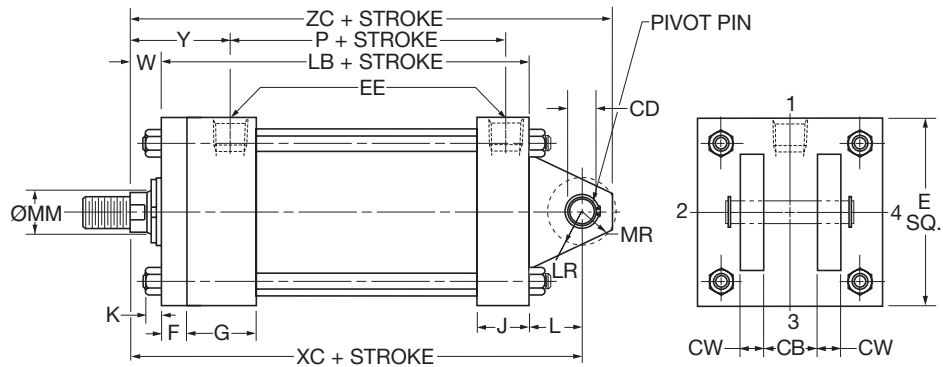
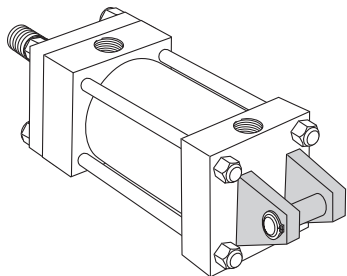

8.00" Bore

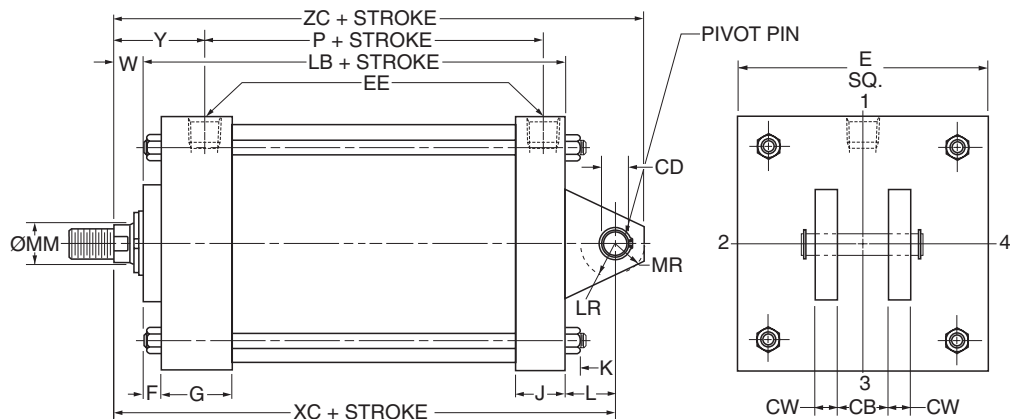
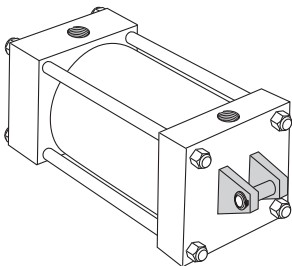

Table 1 – Dimensional and Mounting Data

Bore Ø	CB	CD ³ Ø +0.000 -0.002	CW	E	EE		F	G	J	K	L	LR	MR	Add Stroke	
					NPTF ¹	SAE ²								LB	P
6.00	1.50	1.001	0.75	6.50	3/4	12	0.75	2.00	1.50	0.44	1.50	1.25	1.19	5.75	3.13
8.00	1.50	1.001	0.75	8.50	3/4	12	0.75	2.00	1.50	0.56	1.50	1.25	1.19	5.88	3.25

¹ NPTF ports will be furnished as standard unless SAE straight thread ports are specified.

² SAE straight thread ports are indicated by port number.

³ Dimension CD is pin diameter.

Table 2 – Dimensional and Mounting Data

Bore Ø	Rod No.	MM Rod Ø	W	Y	Add Stroke	
					XC	ZC
6.00	1 (Std.)	1.750	1.13	3.06	8.38	9.38
	2	4.000	1.50	3.44	8.75	9.75
	3	2.000	1.25	3.19	8.50	9.50
	4	2.500	1.50	3.44	8.75	9.75
	5	3.000	1.50	3.44	8.75	9.75
	6	3.500	1.50	3.44	8.75	9.75
	7	1.375	0.88	2.81	8.13	9.13
8.00	1 (Std.)	2.000	1.25	3.19	8.63	9.63
	2	5.500	1.50	3.44	8.88	9.88
	3	2.500	1.50	3.44	8.88	9.88
	4	3.000	1.50	3.44	8.88	9.88
	5	3.500	1.50	3.44	8.88	9.88
	6	4.000	1.50	3.44	8.88	9.88
	7	1.375	0.88	2.81	8.25	9.25
	8	1.750	1.13	3.06	8.50	9.50
	9	4.500	1.50	3.44	8.88	9.88
	0	5.000	1.50	3.44	8.88	9.88



Head Trunnion Mounting

Style D
(NFPA Style MT1)

6.00" Bore

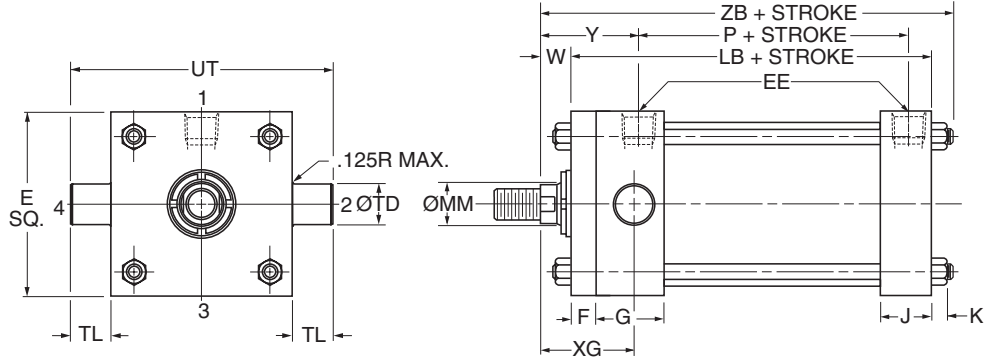
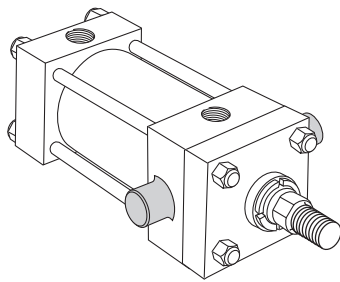

8.00" Bore

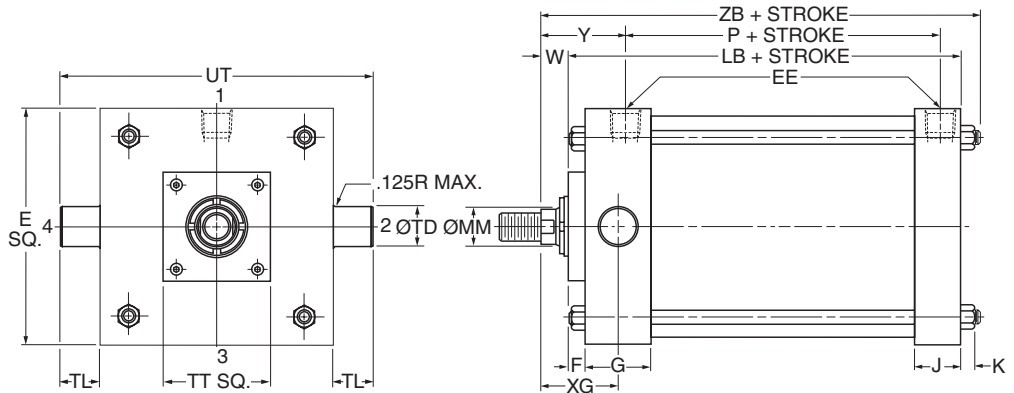
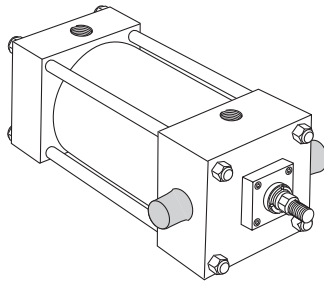

Table 1 – Dimensional and Mounting Data

Bore Ø	E	EE		F	G	J	K	TD Ø +.000 -.001	TL	UT	Add Stroke	
		NPTF ¹	SAE ²								LB	P
6.00	6.50	3/4	12	0.75	2.00	1.50	0.44	1.375	1.38	9.25	5.75	3.13
8.00	8.50	3/4	12	0.75	2.00	1.50	0.56	1.375	1.38	11.25	5.88	3.25

¹ NPTF ports will be furnished as standard unless SAE straight thread ports are specified.

² SAE straight thread ports are indicated by port number.

Table 2 – Dimensional and Mounting Data

Bore Ø	Rod No.	MM Rod Ø	TT	W	XG	Y	Add Stroke
							ZB Max.
6.00	1 (Std.)	1.750	–	1.13	2.88	3.06	7.56
	2	4.000	–	1.50	3.25	3.44	7.94
	3	2.000	–	1.25	3.00	3.19	7.69
	4	2.500	–	1.50	3.25	3.44	7.44
	5	3.000	–	1.50	3.25	3.44	7.44
	6	3.500	–	1.50	3.25	3.44	7.44
	7	1.375	–	0.88	2.63	2.81	7.31
8.00	1 (Std.)	2.000	4.00	1.25	3.00	3.19	7.94
	2	5.500	7.00	1.50	3.25	3.44	8.19
	3	2.500	4.00	1.50	3.25	3.44	8.19
	4	3.000	5.50	1.50	3.25	3.44	8.19
	5	3.500	5.50	1.50	3.25	3.44	8.19
	6	4.000	5.50	1.50	3.25	3.44	8.19
	7	1.375	4.00	0.88	2.63	2.81	7.56
	8	1.750	4.00	1.13	2.88	3.06	7.81
	9	4.500	7.00	1.50	3.25	3.44	8.19
0	5.000	7.00	1.50	3.25	3.44	8.19	

Cap Trunnion Mounting

Style DB
(NFPA Style MT2)

6.00" Bore

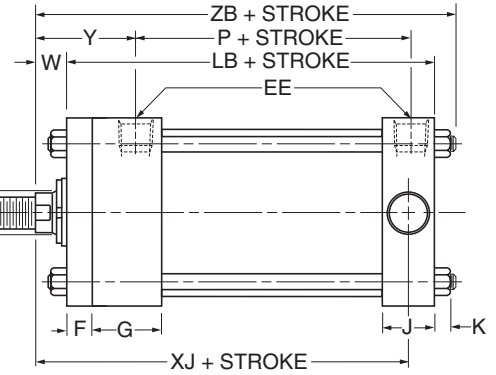
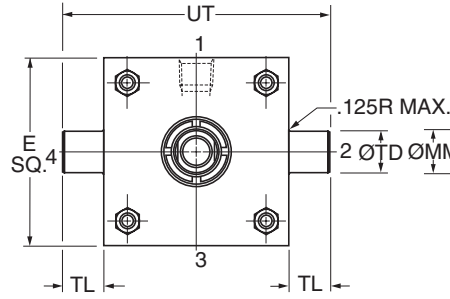
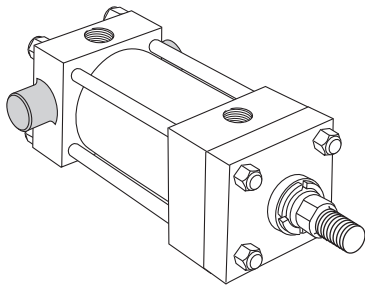

8.00" Bore

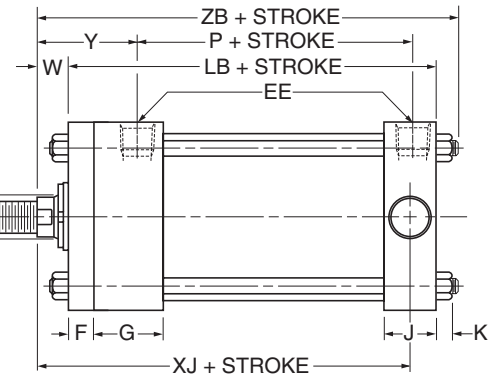
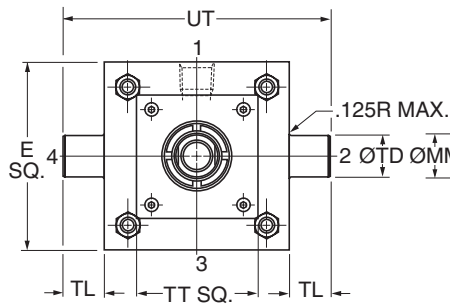
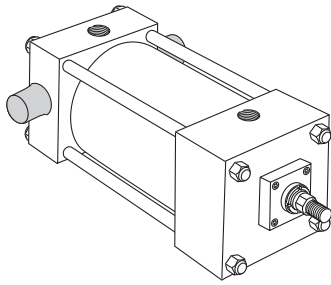

Table 1 – Dimensional and Mounting Data

Bore Ø	E	EE		F	G	J	K	TD Ø +.000 -.001	TL	UT	Add Stroke	
		NPTF ¹	SAE ²								LB	P
6.00	6.50	3/4	12	0.75	2.00	1.50	0.44	1.375	1.38	9.25	5.75	3.13
8.00	8.50	3/4	12	0.75	2.00	1.50	0.56	1.375	1.38	11.25	5.88	3.25

¹ NPTF ports will be furnished as standard unless SAE straight thread ports are specified.

² SAE straight thread ports are indicated by port number.

Table 2 – Dimensional and Mounting Data

Bore Ø	Rod No.	MM Rod Ø	TT	W	Y	Add Stroke	
						XJ	ZB Max.
6.00	1 (Std.)	1.750	–	1.13	3.06	6.13	7.56
	2	4.000	–	1.50	3.44	6.50	7.94
	3	2.000	–	1.25	3.19	6.25	7.69
	4	2.500	–	1.50	3.44	6.50	7.44
	5	3.000	–	1.50	3.44	6.50	7.44
	6	3.500	–	1.50	3.44	6.50	7.44
	7	1.375	–	0.88	2.81	5.88	7.31
8.00	1 (Std.)	2.000	4.00	1.25	3.19	6.38	7.94
	2	5.500	7.00	1.50	3.44	6.63	8.19
	3	2.500	4.00	1.50	3.44	6.63	8.19
	4	3.000	5.50	1.50	3.44	6.63	8.19
	5	3.500	5.50	1.50	3.44	6.63	8.19
	6	4.000	5.50	1.50	3.44	6.63	8.19
	7	1.375	4.00	0.88	2.81	6.00	7.56
	8	1.750	4.00	1.13	3.06	6.25	7.81
	9	4.500	7.00	1.50	3.44	6.63	8.19
	0	5.000	7.00	1.50	3.44	6.63	8.19



Intermediate Fixed Trunnion Mounting

Style DD
(NFPA Style MT4)

6.00" Bore

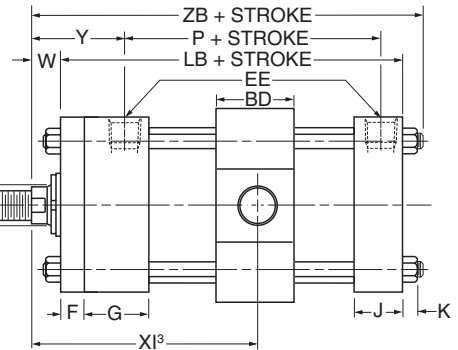
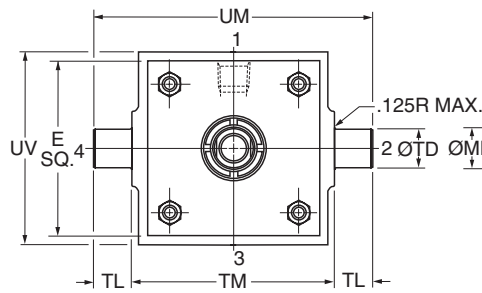
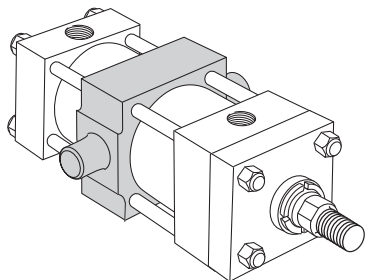

8.00" Bore

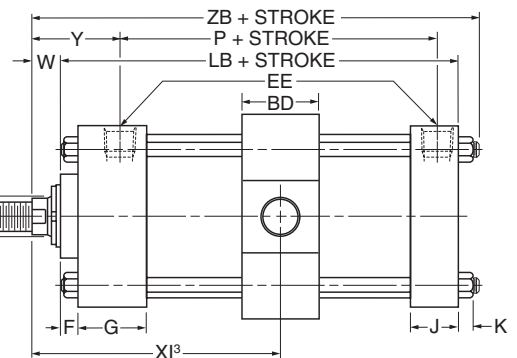
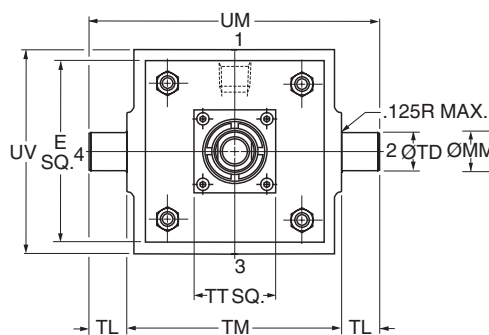
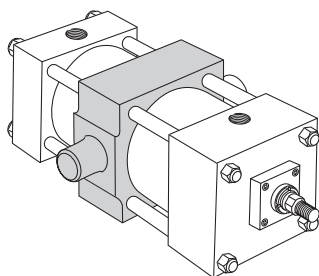

Table 1 – Dimensional and Mounting Data

Bore Ø	BD	E	EE		F	G	J	K	TD Ø +.000 - .001	TL	TM	UM	UV	Add Stroke	
			NPTF ¹	SAE ²										LB	P
6.00	2.50	6.50	3/4	12	0.75	2.00	1.50	0.44	1.375	1.38	7.63	10.38	7.00	5.75	3.13
8.00	2.50	8.50	3/4	12	0.75	2.00	1.50	0.56	1.375	1.38	9.75	12.50	9.50	5.88	3.25

¹ NPTF ports will be furnished as standard unless SAE straight thread ports are specified.

² SAE straight thread ports are indicated by port number.

Table 2 – Dimensional and Mounting Data

Bore Ø	Rod No.	MM Rod Ø	TT	W	Min. ³ XI	Min. Stroke	Y	Add Stroke
								ZB Max.
6.00	1 (Std.)	1.750	–	1.13	5.19	0.88	3.06	7.56
	2	4.000	–	1.50	5.56	0.88	3.44	7.94
	3	2.000	–	1.25	5.31	0.88	3.19	7.69
	4	2.500	–	1.50	5.56	0.88	3.44	7.44
	5	3.000	–	1.50	5.56	0.88	3.44	7.44
	6	3.500	–	1.50	5.56	0.88	3.44	7.44
	7	1.375	–	0.88	4.94	0.88	2.81	7.31
8.00	1 (Std.)	2.000	4.00	1.25	5.31	0.75	3.19	7.94
	2	5.500	7.00	1.50	5.56	0.75	3.44	8.19
	3	2.500	4.00	1.50	5.56	0.75	3.44	8.19
	4	3.000	5.50	1.50	5.56	0.75	3.44	8.19
	5	3.500	5.50	1.50	5.56	0.75	3.44	8.19
	6	4.000	5.50	1.50	5.56	0.75	3.44	8.19
	7	1.375	4.00	0.88	4.94	0.75	2.81	7.56
	8	1.750	4.00	1.13	5.19	0.75	3.06	7.81
	9	4.500	7.00	1.50	5.56	0.75	3.44	8.19
	0	5.000	7.00	1.50	5.56	0.75	3.44	8.19

³ Dimension XI to be specified by customer.

Spherical Bearing Mounting

Style SB

6.00" Bore

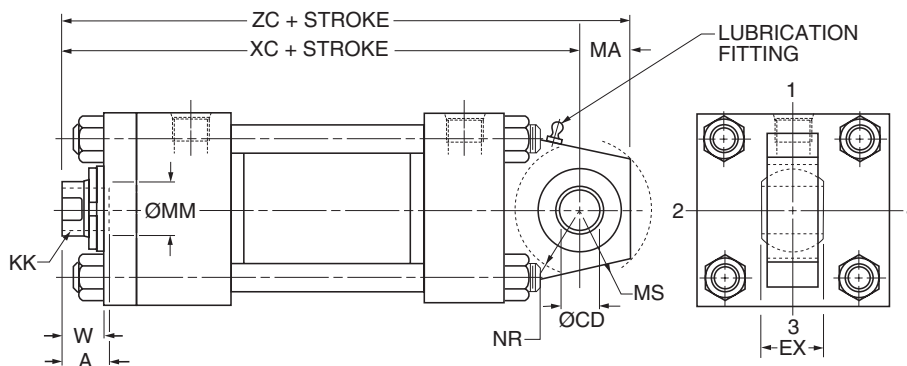

8.00" Bore

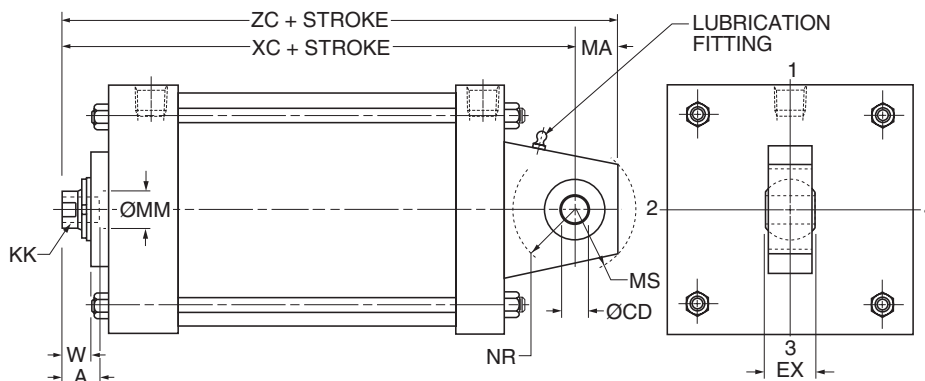

Table 1 – Dimensional and Mounting Data

Bore Ø	Rod No.	MM Rod Ø	Rod End Thread		A	CD ² Ø	EX	MA	MS	NR	W	Add Stroke		Max. Oper. psi ³	
			Style 7 KK ¹	Style 9 KK ¹								XC	ZC		
6.00	1 (Std.)	1.750	1-14	–	1.63	-.0005 1.0000	0.88	1.25	1.69	1.25	1.13	8.38	9.63	440	
	2	4.000	1-14	–	1.63							1.50	8.75		10.00
	3	2.000	1-14	–	1.63							1.25	8.50		9.75
	4	2.500	1-14	–	1.63							1.50	8.75		10.00
	5	3.000	1-14	–	1.63							1.50	8.75		10.00
	6	3.500	1-14	–	1.63							1.50	8.75		10.00
	7	1.375	–	1-14	1.63							0.88	8.13		9.38
8.00	1 (Std.)	2.000	1-14	–	1.63	-.0005 1.0000	0.88	1.25	1.69	1.25	1.25	8.63	9.88	250	
	2	5.500	1-14	–	1.63							1.50	8.88		10.13
	3	2.500	1-14	–	1.63							1.50	8.88		10.13
	4	3.000	1-14	–	1.63							1.50	8.88		10.13
	5	3.500	1-14	–	1.63							1.50	8.88		10.13
	6	4.000	1-14	–	1.63							1.50	8.88		10.13
	7	1.375	–	1-14	1.63							0.88	8.25		9.50
	8	1.750	1-14	–	1.63							1.13	8.50		9.75
	9	4.500	1-14	–	1.63							1.50	8.88		10.13
	0	5.000	1-14	–	1.63							1.50	8.88		10.13

¹ Threads listed are also for a spherical rod eye which match style 9 or style 7. The spherical rod eye pin diameter matches the cap pin and (if required) needs to be purchased separately. See 3L Mounting Accessories for detailed information.

² Dimension CD is hole diameter.

³ Maximum operating pressure at 4:1 design factor is based on tensile strength of material. Pressure ratings are based on standard commercial bearing ratings.

Note: For additional dimensions see Series 3L, Style BB mount.



Double Rod Models – 1.00" to 8.00" Bore

Mounting Styles for Single Rod Models	Mounting Styles for Corresponding Double Rod Models ¹	Dimensions Shown on This Page Supplement Dimensions on Pages Listed Below	
		1.00" - 5.00" Bores Page No.	6.00" & 8.00" Bores Page No.
T	KT	12	28
TB	KTB	12	28
TD	KTD	12	28
J	KJ	13	13 ³
JB	KJB	14	29
JJ	KJJ	15	–
C	KC	18	31
F	KF	19	32
D	KD	21	34
DD	KDD ²	23	36

¹ If only one end of these Double Rod Cylinders is to be cushioned, be sure to specify clearly which end this will be.

² Specify XI dimension from rod end #1.

³ 6.00" bore only.

How to Use Double Rod Cylinder Dimension Drawings

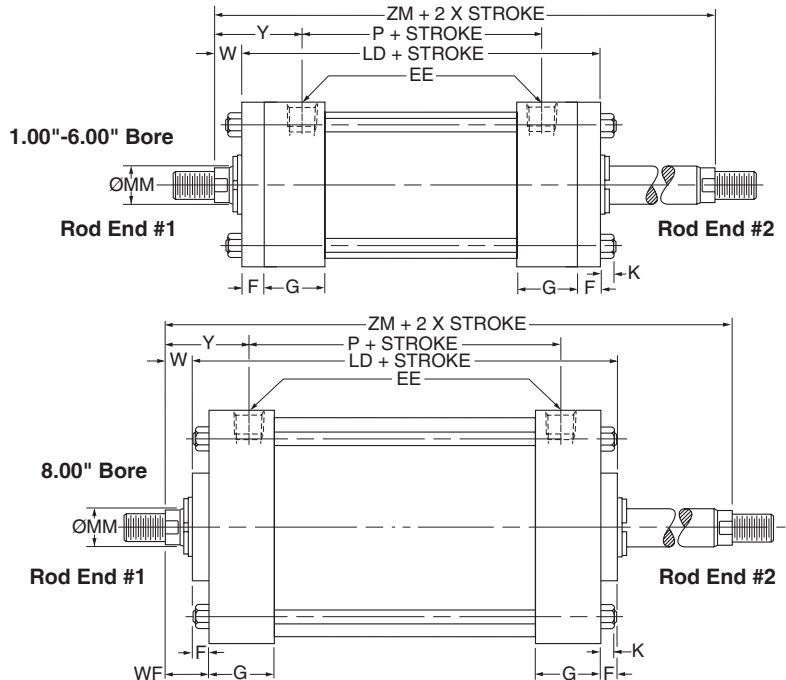

Bore Ø	Rod No.	MM Rod Ø	Add Stroke			Add 2X Stroke
			LD	SNK	SSK	ZM
1.00	1 (Std.)	0.500	4.75	2.13	3.38	6.00
	2	0.625	4.75	2.13	3.38	6.00
1.50	1 (Std.)	0.625	4.88	2.25	3.38	6.13
	2	1.000	4.88	2.25	3.38	6.88
2.00	1 (Std.)	0.625	4.88	2.25	3.38	6.13
	2	1.375	4.88	2.25	3.38	7.38
2.50	1 (Std.)	1.000	5.00	2.38	3.50	7.00
	2	1.750	5.00	2.38	3.50	8.00
	3	1.375	5.00	2.38	3.50	7.50
	7	0.625	5.00	2.38	3.50	6.25
3.25	1 (Std.)	1.000	6.00	2.63	3.75	7.50
	2	2.000	6.00	2.63	3.75	8.75
	3	1.375	6.00	2.63	3.75	8.00
Replaces On single rod mounting styles:			LB	SN	SS	–
			All Mtg. Styles	F	C	All Mtg. Styles

Bore Ø	Rod No.	MM Rod Ø	Add Stroke			Add 2X Stroke
			LD	SNK	SSK	ZM
4.00	1 (Std.)	1.375	6.00	2.63	3.75	8.00
	2	2.500	6.00	2.63	3.75	9.25
	3	1.750	6.00	2.63	3.75	8.50
	4	2.000	6.00	2.63	3.75	8.75
5.00	7	1.000	6.00	2.63	3.75	7.50
	1 (Std.)	1.750	6.25	2.88	3.63	8.75
	2	3.500	6.25	2.88	3.63	9.50
	3	2.000	6.25	2.88	3.63	9.00
	4	2.500	6.25	2.88	3.63	9.50
	5	3.000	6.25	2.88	3.63	9.50
	7	1.000	6.25	2.88	3.63	7.75
	8	1.375	6.25	2.88	3.63	8.25
6.00	1 (Std.)	1.750	7.00	3.13	4.13	9.25
	2	4.000	7.00	3.13	4.13	10.00
	3	2.000	7.00	3.13	4.13	9.50
	4	2.500	7.00	3.13	4.13	10.00
	5	3.000	7.00	3.13	4.13	10.00
	6	3.500	7.00	3.13	4.13	10.00
	7	1.375	7.00	3.13	4.13	8.75
8.00	1 (Std.)	2.000	7.13	3.25	4.25	9.63
	2	5.500	7.13	3.25	4.25	10.13
	3	2.500	7.13	3.25	4.25	10.13
	4	3.000	7.13	3.25	4.25	10.13
	5	3.500	7.13	3.25	4.25	10.13
	6	4.000	7.13	3.25	4.25	10.13
	7	1.375	7.13	3.25	4.25	8.88
	8	1.750	7.13	3.25	4.25	9.38
	9	4.500	7.13	3.25	4.25	10.13
	0	5.000	7.13	3.25	4.25	10.13
Replaces On single rod mounting styles:			LB	SN	SS	–
			All Mtg. Styles	F	C	All Mtg. Styles

To determine dimensions for a double rod cylinder, first refer to the desired single rod mounting style cylinder shown on preceding pages of this catalog. (See table above.) After selecting necessary dimensions from that drawing, return to this page and supplement the single rod dimensions with those shown on drawings above and dimension table below. Note that double rod cylinders have a head (Dim. G) at both ends and that dimension LD replaces LB. The double rod dimensions differ from, or are in addition to those for single rod cylinders shown on preceding pages and provide the information needed to completely dimension a double rod cylinder.

On a double rod cylinder where the two rod ends are different, be sure to clearly state which rod end is to be assembled at which end. Port position 1 is standard. If other than standard, specify pos. 2, 3 or 4 when viewed from rod end #1 only. (See port position information in Section D.)



Notes

Notes

Section B

.....

Cylinder Accessories and Replacement Parts

Cylinder Mounting Accessories	42
Spherical Bearing Mount Accessories	46
Linear Alignment Couplers	47
Style 55 Split Couplers and Weld Plates	49
Parts List and Seal Kits	50



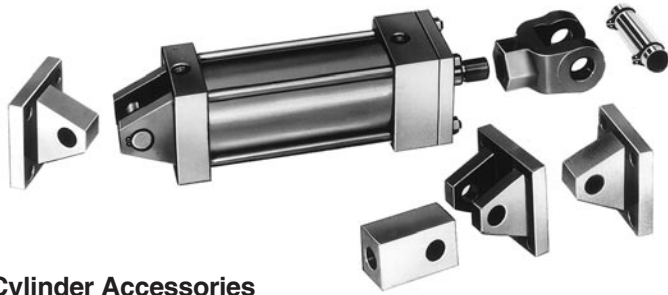

Cylinder Accessories

Parker offers a complete range of cylinder accessories to assure flexibility and versatility in present or future cylinder applications.

Rod End Accessories

Accessories offered for the rod end of the cylinder include: Rod Clevis, Eye Bracket, Knuckle, Clevis Bracket and Pivot Pin. To select the proper part number for any desired accessory, refer to Chart A below and look opposite the thread size of the rod end as indicated in the first column. The Pivot Pins, Eye Brackets and Clevis Brackets are listed opposite the thread size which their mating Knuckles or Clevises fit.

Accessory Load Capacity

The various accessories on this and the following pages have been load rated for your convenience. The load capacity in lbs. is the recommended maximum load for that accessory based on a 4:1 design factor in tension. (Pivot Pin is rated in shear.) Before specifying, compare the actual load or the tension (pull) force at maximum operating pressure of the cylinder with the load capacity of the accessory you plan to use. If load or pull force of cylinder exceeds load capacity of accessory, consult factory.

Series 3L Accessory Part Numbers & Load Capacity Chart A

Thread Size	Rod Clevis		Mounting Plate or Eye Bracket		Pivot Pin	
	Part Number	Load Capacity (Lbs.)	Part Number	Load Capacity (Lbs.)	Part Number	Shear Capacity (Lbs.)
5/16-24	0512210000 ¹	2600	0740770000	1700	—	—
7/16-20	0509400000	4250	0691950000	4100	0683680000	8600
1/2-20	0509410000	4900	0691950000	4100	0683680000	8600
3/4-16	0509420000	11200	0691960000	10500	0683690000	19300
3/4-16	1332840000	11200	0691960000	10500	0683690000	19300
7/8-14	0509430000	18800	² 0853610000	20400	0683700000	34300
1-14	0509440000	19500	² 0853610000	20400	0683700000	34300
1-14	1332850000	19500	² 0853610000	20400	0683700000	34300
1 1/4-12	0509450000	33500	0691980000	21200	0683710000	65000
1 1/4-12	1332860000	33500	0691980000	21200	0683710000	65000
1 1/2-12	0509460000	45600	² 0853620000	43300	0683720000	105200
1 3/4-12	0509470000	65600	² 0853630000	70000	0683730000	137400
1 7/8-12	0509480000	65600	² 0853630000	70000	0683730000	137400
2 1/4-12	0509490000	98200	² 0853640000	94200	0683740000	214700
2 1/2-12	0509500000	98200	² 0853650000	121900	0683750000	309200
2 3/4-12	0509510000	98200	² 0853650000	121900	0683750000	309200
3 1/4-12	0509520000	156700	0735380000	57400	0735450000	420900
3 1/2-12	0509530000	193200	0735390000	75000	0735470000	565800
4-12	0509540000	221200	0735390000	75000	0735470000	565800

Mounting Plates

Mounting Plates for Style BB (clevis mounted) cylinders are offered. To select proper part number for your application, refer to Chart B at right.

Chart B

Mtg. Plate Part No.	Series 3L Bore Size
0740760000	1.00
0691950000	1.50, 2.00, 2.50
0691960000	3.25, 4.00, 5.00
0853610000	6.00, 8.00

¹ Includes pivot pin.

² Cylinder accessory dimensions conform to NFPA recommended standard NFPA/T3.6.8 R1-1984, NFPA recommended standard fluid power systems – cylinder – dimensions for accessories for cataloged square head industrial cylinders.

Rod Clevis Dimensions

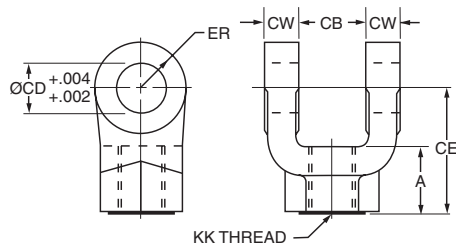

Pivot Pin Dimensions

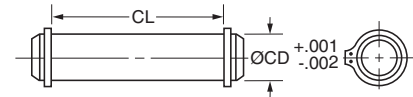

Part Number	A	CB	CD Ø	CE	CW	ER	KK
0512210000 ¹	0.81	0.34	0.313	2.25	0.20	0.30	5/16-24
0509400000	0.75	0.75	0.500	1.50	0.50	0.50	7/16-20
0509410000	0.75	0.75	0.500	1.50	0.50	0.50	1/2-20
0509420000	1.13	1.25	0.750	2.13	0.63	0.75	3/4-16
1332840000	1.13	1.25	0.750	2.38	0.63	0.75	3/4-16
0509430000	1.63	1.50	1.000	2.94	0.75	1.00	7/8-14
0509440000	1.63	1.50	1.000	2.94	0.75	1.00	1-14
1332850000	1.63	1.50	1.000	3.13	0.75	1.00	1-14
0509450000	1.88	2.00	1.375	3.75	1.00	1.38	1 1/4-12
1332860000	2.00	2.00	1.375	4.13	1.00	1.38	1 1/4-12
0509460000	2.25	2.50	1.750	4.50	1.25	1.75	1 1/2-12
0509470000	3.00	2.50	2.000	5.50	1.25	2.00	1 3/4-12
0509480000	3.00	2.50	2.000	5.50	1.25	2.00	1 7/8-12
0509490000	3.50	3.00	2.500	6.50	1.50	2.50	2 1/4-12
0509500000	3.50	3.00	3.000	6.75	1.50	2.75	2 1/2-12
0509510000	3.50	3.00	3.000	6.75	1.50	2.75	2 3/4-12
0509520000	3.50 ²	4.00	3.500	7.75	2.00	3.50	3 1/4-12
0509530000	4.00 ²	4.50	4.000	8.81	2.25	4.00	3 1/2-12
0509540000	4.00 ²	4.50	4.000	8.81	2.25	4.00	4-12

Part Number	CD Ø	CL
0683680000	0.500	1.88
0683690000	0.750	2.63
0683700000	1.000	3.13
0683710000	1.375	4.13
0683720000	1.750	5.19
0683730000	2.000	5.19
0683740000	2.500	6.19
0683750000	3.000	6.25
0735450000	3.500	8.25
0735470000 ³	4.000	9.00

³This size supplied with cotter pins.

1. Pivot Pins are furnished with Clevis Mounted Cylinders as standard.
2. Pivot Pins are furnished with (2) Retainer Rings.
3. Pivot Pins must be ordered as a separate item if to be used with Knuckles, Rod Clevises, or Clevis Brackets.

¹ Includes Pivot Pin

² Consult appropriate cylinder rod end dimensions for compatibility.

Mounting Plate or Eye Bracket Dimensions

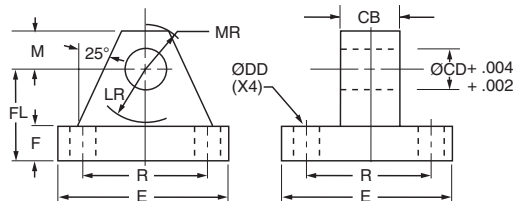

When used to mate with the Rod Clevis, select by thread size in table on opposite page.

Part Number	CB	CD Ø	DD Ø	E	F	FL	LR	M	MR	R
0740770000	0.31	0.313	0.27	2.25	0.38	1.00	0.63	0.38	0.50	1.75
0691950000	0.75	0.500	0.41	2.50	0.38	1.13	0.75	0.50	0.56	1.63
0691960000	1.25	0.750	0.53	3.50	0.63	1.88	1.25	0.75	0.88	2.55
⁴ 0853610000	1.50	1.000	0.66	4.50	0.88	2.38	1.50	1.00	1.25	3.25
0691980000	2.00	1.375	0.66	5.00	0.88	3.00	2.13	1.38	1.63	3.82
⁴ 0853620000	2.50	1.750	0.91	6.50	1.13	3.38	2.25	1.75	2.13	4.95
⁴ 0853630000	2.50	2.000	1.06	7.50	1.50	4.00	2.50	2.00	2.44	5.73
⁴ 0853640000	3.00	2.500	1.19	8.50	1.75	4.75	3.00	2.50	3.00	6.58
⁴ 0853650000	3.00	3.000	1.31	9.50	2.00	5.25	3.25	2.75	3.25	7.50
0735380000	4.00	3.500	1.81	12.63	1.69	5.69	4.00	3.50	4.13	9.62
0735390000	4.50	4.000	2.06	14.88	1.94	6.44	4.50	4.00	5.25	11.45

⁴ Cylinder accessory dimensions conform to NFPA recommended standard NFPA/T3.6.8 R1-1984, NFPA recommended standard fluid power systems - cylinder - dimensions for accessories for cataloged square head industrial cylinders.



Rod End Accessories

Accessories offered for the rod end of the cylinder include Rod Clevis, Eye Bracket, Knuckle, Clevis Bracket, and Pivot Pin. To select the proper part number for any desired accessory, refer to the table below or on the opposite page and look in the row to the right of the rod thread in the first column. For economical accessory selection, it is recommended that rod end style 2 be specified on your cylinder order.

Accessory Load Capacity

The various accessories have been load rated for your convenience. The load capacity in lbs. is the recommended maximum load for that accessory based on a 4:1 design factor in tension. (Pivot Pin is rated in shear.) Before specifying, compare the actual load or the tension (pull) force at the maximum operating pressure of the cylinder with the load capacity of the accessory you plan to use. If load or pull force of cylinder exceeds load capacity of accessory, consult factory.

Thread Size	Knuckle		Clevis Bracket		Pivot Pin	
	Part Number	Load Capacity (Lbs.)	Part Number	Load Capacity (Lbs.)	Part Number	Shear Capacity (Lbs.)
5/16-24	0740750000	3300	0740760000	3600	0740780000	6600
7/16-20	0690890000	5000	0692050000	7300	0683680000	8600
1/2-20	0690900000	5700	0692050000	7300	0683680000	8600
3/4-16	0690910000	12100	0692060000	14000	0683690000	19300
7/8-14	0690920000	13000	0692070000	19200	0683700000	34300
1-14	0690930000	21700	0692070000	19200	0683700000	34300
1 1/4-12	0690940000	33500	0692080000	36900	0683710000	65000
1 1/2-12	0690950000	45000	0692090000	34000	0683720000	105200
1 3/4-12	0690960000	53500	0692100000	33000	0692150000	137400
1 7/8-12	0690970000	75000	0692100000	33000	0692150000	137400
2 1/4-12	0690980000	98700	0692110000	34900	0683740000	214700
2 1/2-12	0690990000	110000	0692120000	33800	0683750000	309200
2 3/4-12	0691000000	123300	0692130000	36900	0692160000	309200
3 1/4-12	0735360000	161300	0735420000	83500	0735450000	420900
3 1/2-12	0734370000	217300	0735420000	83500	0735450000	420900
4-12	0734380000	273800	0735430000	102600	0821810000	565800
4 1/2-12	0734390000	308500	0735440000	108400	0735470000 ¹	565800

¹This size supplied with cotter pins.

Knuckle Dimensions

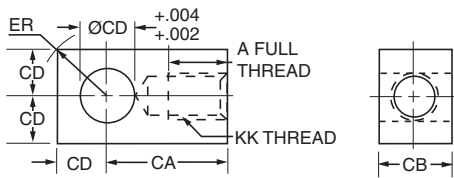

Pivot Pin Dimensions

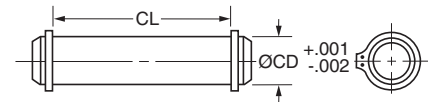

Part Number	A	CA	CB	CD	ER	KK
0740750000	0.75	1.50	0.44	0.438	0.59	5/16-24
0690890000	0.75	1.50	0.75	0.500	0.72	7/16-20
0690900000	0.75	1.50	0.75	0.500	0.72	1/2-20
0690910000	1.13	2.06	1.25	0.750	1.06	3/4-16
0690920000	1.13	2.38	1.50	1.000	1.44	7/8-14
0690930000	1.63	2.81	1.50	1.000	1.44	1-14
0690940000	2.00	3.44	2.00	1.375	1.97	1 1/4-12
0690950000	2.25	4.00	2.50	1.750	2.50	1 1/2-12
0690960000	2.25	4.38	2.50	2.000	2.84	1 3/4-12
0690970000	3.00	5.00	2.50	2.000	2.84	1 7/8-12
0690980000	3.50	5.81	3.00	2.500	3.56	2 1/4-12
0690990000	3.50	6.13	3.00	3.000	4.25	2 1/2-12
0691000000	3.63	6.50	3.50	3.000	4.25	2 3/4-12
0735360000	4.50	7.63	4.00	3.500	4.97	3 1/4-12
0734370000	5.00	7.63	4.00	3.500	4.97	3 1/2-12
0734380000	5.50	9.13	4.50	4.000	5.69	4-12
0734390000	5.50	9.13	5.00	4.000	5.69	4 1/2-12

Part Number	CD Ø	CL
0740780000	0.438	1.31
0683680000	0.500	1.88
0683690000	0.750	2.63
0683700000	1.000	3.13
0683710000	1.375	4.13
0683720000	1.750	5.19
0692150000	2.000	5.69
0683740000	2.500	6.19
0683750000	3.000	6.25
0692160000	3.000	6.75
0735450000	3.500	8.25
0821810000	4.000	8.63
0735470000 ¹	4.000	9.00

¹This size supplied with cotter pins.

1. Pivot Pins are furnished with Clevis Mounted Cylinders as standard.
2. Pivot Pins are furnished with (2) Retainer Rings.
3. Pivot Pins must be ordered as a separate item if to be used with Knuckles, Rod Clevises, or Clevis Brackets.

Clevis Bracket Dimensions

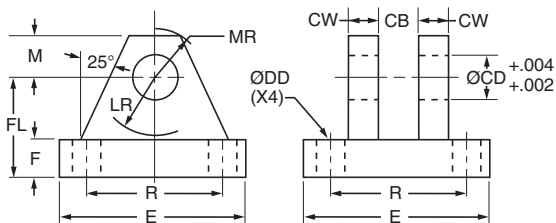

Part Number	CB	CD Ø	CW	DD Ø	E	F	FL	LR	M	MR	R
0740760000	0.47	0.438	0.38	0.27	2.25	0.38	1.00	0.63	0.38	0.50	1.75
0692050000	0.75	0.500	0.50	0.41	3.50	0.50	1.50	0.75	0.50	0.63	2.55
0692060000	1.25	0.750	0.63	0.53	5.00	0.63	1.88	1.19	0.75	0.91	3.82
0692070000	1.50	1.000	0.75	0.66	6.50	0.75	2.25	1.50	1.00	1.25	4.95
0692080000	2.00	1.375	1.00	0.66	7.50	0.88	3.00	2.00	1.38	1.66	5.73
0692090000	2.50	1.750	1.25	0.91	9.50	0.88	3.63	2.75	1.75	2.22	7.50
0692100000	2.50	2.000	1.50	1.06	12.75	1.00	4.25	3.19	2.25	2.78	9.40
0692110000	3.00	2.500	1.50	1.19	12.75	1.00	4.50	3.50	2.50	3.13	9.40
0692120000	3.00	3.000	1.50	1.31	12.75	1.00	6.00	4.25	3.00	3.59	9.40
0692130000	3.50	3.000	1.50	1.31	12.75	1.00	6.00	4.25	3.00	3.59	9.40
0735420000	4.00	3.500	2.00	1.81	15.50	1.69	6.69	5.00	3.50	4.13	12.00
0735430000	4.50	4.000	2.00	2.06	17.50	1.94	7.69	5.75	4.00	4.88	13.75
0735440000	5.00	4.000	2.00	2.06	17.50	1.94	7.69	5.75	4.00	4.88	13.75

Cylinder accessory dimensions conform to NFPA recommended standard NFPT/T3.6.8 R1-1984, NFPA recommended standard fluid power systems – cylinder – dimensions for accessories for cataloged square head industrial cylinders.



Parker offers a complete range of Cylinder Accessories to assure you of the greatest versatility in present or future cylinder applications. Accessories offered for the

respective cylinder include the Rod Eye, Pivot Pin and Clevis Bracket. To select the proper part number for any desired accessory refer to the charts below.

Spherical Rod Eye

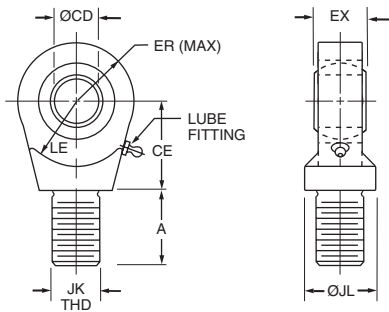

Bore Ø	1.50, 2.00 & 2.50	3.25, 4.00 & 5.00	6.00 & 8.00
Part No.	1322900000	1322910000	1322920000
CD Ø	.5000 ^{-.0005}	.7500 ^{-.0005}	1.0000 ^{-.0005}
A	0.69	1.00	1.50
CE	0.88	1.25	1.88
EX	0.44	0.66	0.88
ER	0.81	1.13	1.25
LE	0.75	1.06	1.44
JK	7/16-20	3/4-16	1-14
JL Ø	0.88	1.31	1.50
LOAD CAPACITY LBS.	2644	9441	16860

Order to fit Piston Rod Thread Size.

Pivot Pin

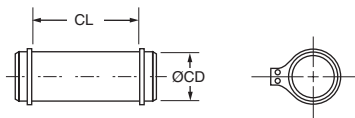

Bore Ø	1.50, 2.00 & 2.50	3.25, 4.00 & 5.00	6.00 & 8.00
Part No.	0839620000	0839630000	0839640000
CD Ø	.4997 ^{-.0004}	.7497 ^{-.0005}	.9997 ^{-.0005}
CL	1.56	2.03	2.50
LOAD CAPACITY LBS.	8600	19300	34300

Pivot Pins are furnished with (2) Retainer Rings.

Clevis Bracket

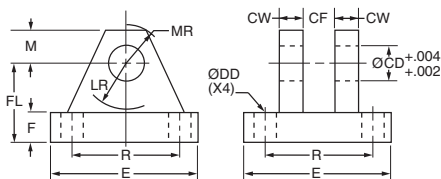

Bore Ø	1.50, 2.00 & 2.50	3.25, 4.00 & 5.00	6.00 & 8.00
Part No.	0839470000	0839480000	0839490000
CD Ø	0.50	0.75	1.00
CF	0.44	0.66	0.88
CW	0.50	0.63	0.75
DD Ø	0.41	1.22	1.22
E	3.00	3.75	5.50
F	0.50	0.63	0.75
FL	1.50	2.00	2.50
LR	0.94	1.38	1.69
M	0.50	0.88	1.00
MR	0.63	1.00	1.19
R	2.05	2.76	4.10
LOAD CAPACITY LBS.	5770	9450	14300

Order to fit Cap or Rod Eye.

Linear Alignment Couplers



- Simplify Cylinder Installation
- Reduce Assembly Time
- Increase Cylinder Bearing and Seal Life
- Reliable Performance In “Push” *and* “Pull” Applications

Linear Alignment Couplers are available in 19 standard thread sizes...

Cost Saving Features and Benefits Include...

- Maximum reliability for trouble-free operation, long life and lower operating costs
- Increased cylinder life by reducing wear on Piston and Rod bearings
- Simplifying Cylinder installation and reducing assembly costs
- Increase Rod Bearing and Rod Seal life for lower maintenance costs

Alignment Coupler

See Table 1 for Part Numbers and Dimensions

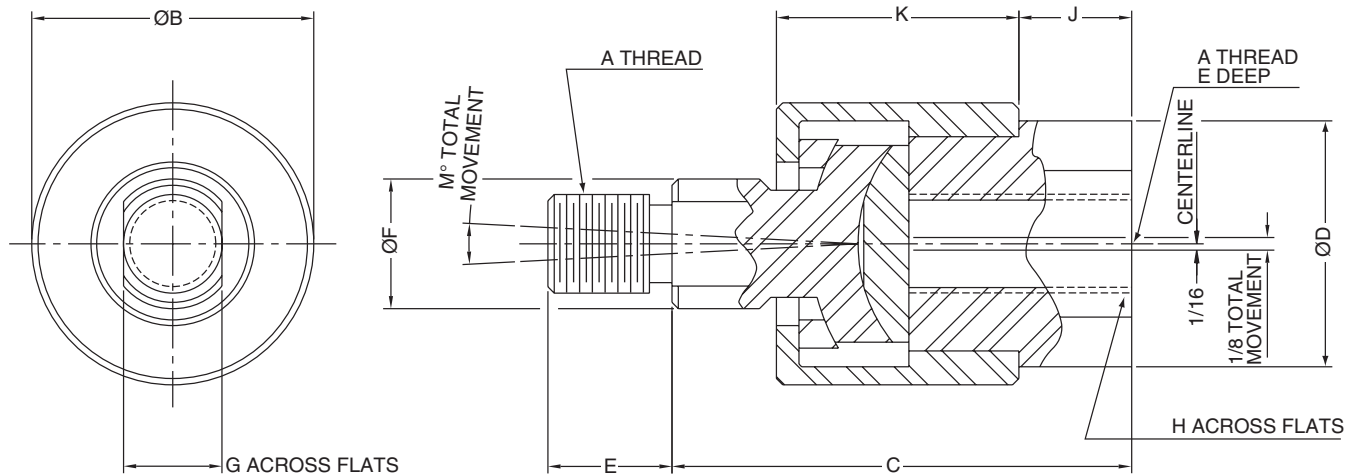

Table 1 — Part Numbers and Dimensions

Part No.	A	B Ø	C	D Ø	E	F Ø	G	H	J	K	M	Max. Pull Load (lbs.)	Approx. Weight (lbs.)
1347570031	5/16-24	1.13	1.75	0.94	0.50	0.50	0.38	0.75	0.38	0.94	6°	1200	.35
1347570038	3/8-24	1.13	1.75	0.94	0.50	0.50	0.38	0.75	0.38	0.94	6°	2425	.35
1347570044	7/16-20	1.38	2.00	1.13	0.75	0.63	0.50	0.88	0.38	1.09	6°	3250	.55
1347570050	1/2-20	1.38	2.00	1.13	0.75	0.63	0.50	0.88	0.38	1.09	6°	4450	.55
1347570063	5/8-18	1.38	2.00	1.13	0.75	0.63	0.50	0.88	0.38	1.09	6°	6800	.55
1347570075	3/4-16	2.00	2.31	1.63	1.13	0.94	0.75	1.31	0.44	1.28	6°	9050	1.4
1347570088	7/8-14	2.00	2.31	1.63	1.13	0.94	0.75	1.31	0.44	1.28	6°	14450	1.4
1347570100	1-14	3.13	3.00	2.38	1.63	1.44	1.25	1.88	0.75	1.78	6°	19425	4.8
1347570125	1 1/4-12	3.13	3.00	2.38	1.63	1.44	1.25	1.88	0.75	1.78	6°	30500	4.8
1337390125	1 1/4-12	3.50	4.00	2.00	2.00	1.50	1.25	1.69	0.75	2.50	6°	30500	6.9
1337390150	1 1/2-12	4.00	4.38	2.25	2.25	1.75	1.50	1.94	0.88	2.75	10°	45750	9.8
1337390175	1 3/4-12	4.00	4.38	2.25	2.25	1.75	1.50	1.94	0.88	2.75	10°	58350	9.8
1337390188	1 7/8-12	5.00	5.63	3.00	3.00	2.25	1.94	2.63	1.38	3.38	10°	67550	19.8
1337390200	2-12	5.00	5.63	3.00	3.00	2.25	1.94	2.63	1.38	3.38	10°	77450	19.8
1337390225	2 1/4-12	6.75	6.38	3.25	3.50	2.75	2.38	2.88	1.63	3.75	10°	99250	35.3
1337390250	2 1/2-12	7.00	6.50	4.00	3.50	3.25	2.88	3.38	1.63	3.88	10°	123750	45.3
1337390275	2 3/4-12	7.00	6.50	4.00	3.50	3.25	2.88	3.38	1.63	3.88	10°	150950	45.3
1337390300	3-12	7.00	6.50	4.00	3.50	3.25	2.88	3.38	1.63	3.88	10°	180850	45.3
1337390325	3 1/4-12	9.25	8.50	5.25	4.50	4.00	3.38	4.50	2.00	5.50	10°	213450	—
1337390425	4 1/4-12	12.88	11.25	7.75	4.50	5.50	4.88	7.00	1.50	8.75	10°	370850	—

How to Order Linear Alignment Couplers — When ordering a cylinder with a threaded male rod end, specify the coupler of equal thread size by part number as listed in Table 1, i.e.; Piston Rod “KK” or “CC” dimension is 3/4" - 16", specify coupler part number 1347570075.

Parker "Style 55" Piston Rod End

Split Couplers and Weld Plates

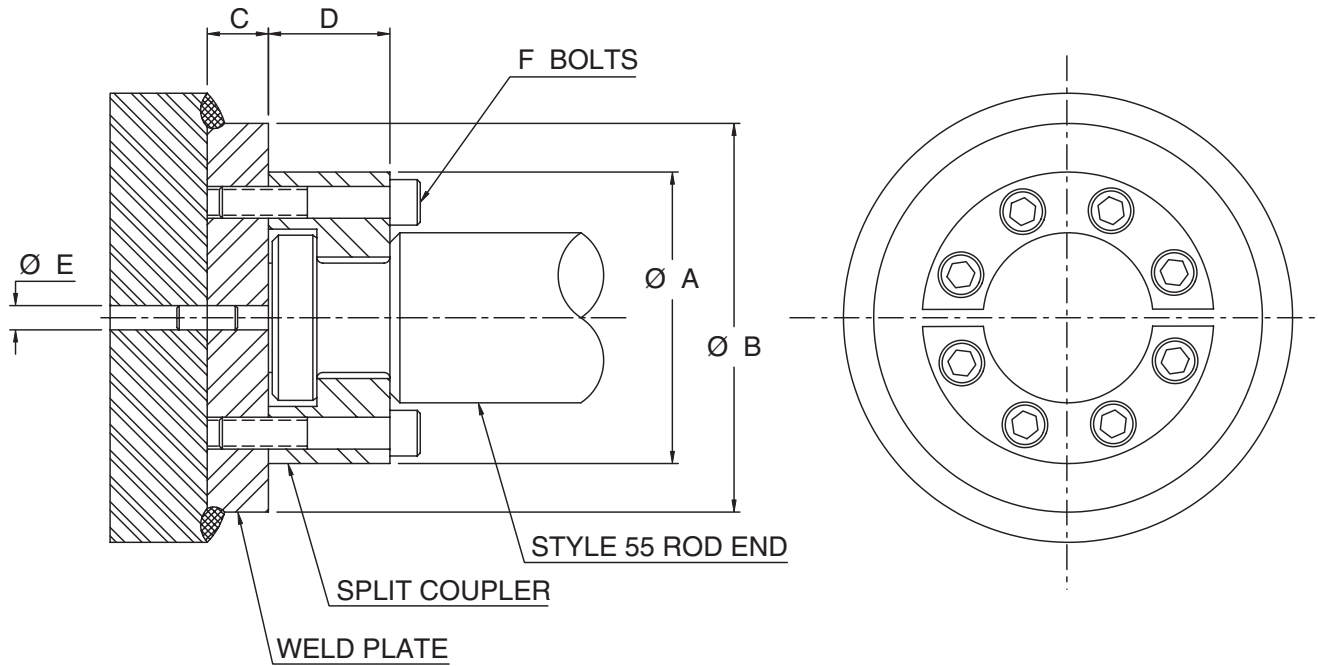

⚠ WARNING: Piston rod separation from the machine member can result in severe personal injury or even death to nearby personnel. The cylinder user must make sure the weld holding the weld plate to the machine is of sufficient quality and size to hold the intended load. The cylinder user must also make sure the bolts holding split coupler to the weld plate are of sufficient strength to hold the intended load and installed in such a way that they will not become loose during the machine's operation.

Table 1 — Part Numbers and Dimensions

Rod Dia.	A Ø	B Ø	C	D	E Ø	F	Bolt Size	Bolt Circle	Split Coupler Part No.	Weld Plate Part No.
.625	1.50	2.00	.50	.56	.250	4	#10-24 x .94 LG	1.125	1472340062	1481740062
1.000	2.00	2.50	.50	.88	.250	6	.250-20 x 1.25 LG	1.500	1472340100	1481740100
1.375	2.50	3.00	.63	1.00	.250	6	.312-18 x 1.0" LG	2.000	1472340138	1481740138
1.750	3.00	4.00	.63	1.25	.250	8	.312-18 x 1.75 LG	2.375	1472340175	1481740175
2.000	3.50	4.00	.75	1.63	.375	12	.375-16 x 2.25 LG	2.687	1472340200	1481740200
2.500	4.00	4.50	.75	1.88	.375	12	.375-16 x 2.50 LG	3.187	1472340250	1481740250
3.000	5.00	5.50	1.00	2.38	.375	12	.500-13 x 3.25 LG	4.000	1472340300	1481740300
3.500	5.88	7.00	1.00	2.63	.375	12	.625-11 x 3.50 LG	4.687	1472340350	1481740350
4.000	6.38	7.00	1.00	2.63	.375	12	.625-11 x 3.50 LG	5.187	1472340400	1481740400
4.500	6.88	8.00	1.00	3.13	.375	12	.625-11 x 4.00 LG	5.687	1472340450	1481740450
5.000	7.38	8.00	1.00	3.13	.375	12	.625-11 x 4.00 LG	6.187	1472340500	1481740500
5.500	8.25	9.00	1.25	3.88	.375	12	.750-10 x 5.00 LG	6.875	1472340550	1481740550

Note: Bolts are not included with split coupler or weld plate.

1.00" through 8.00" Bore

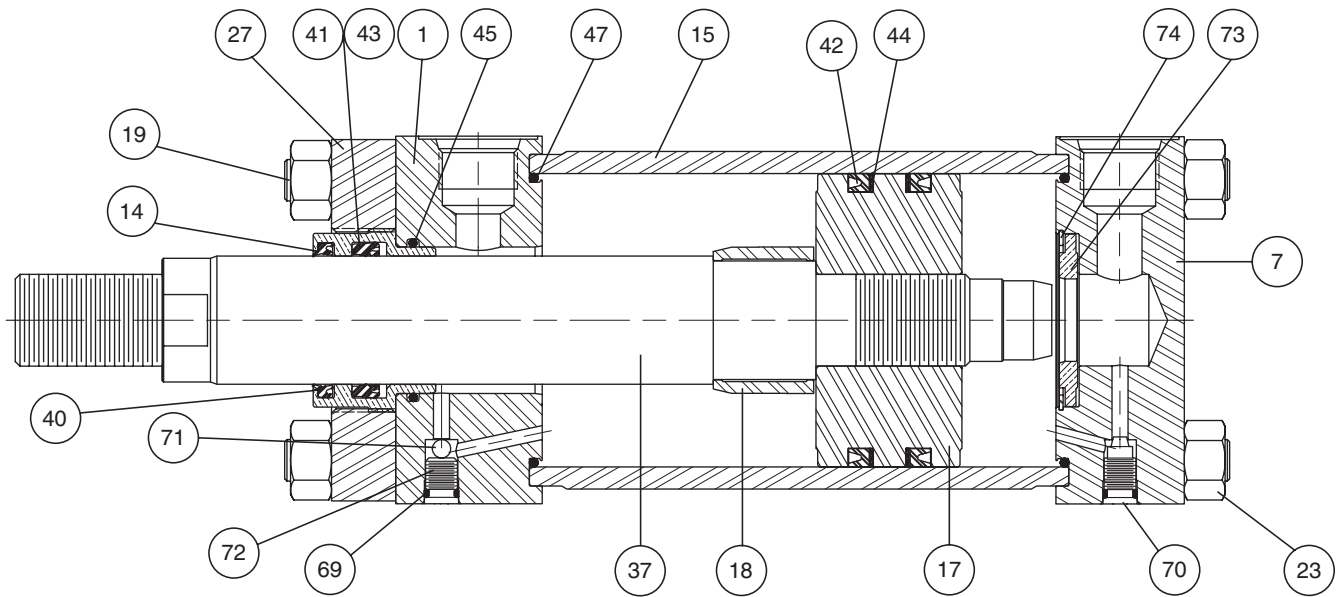

Piston and Rod Assemblies

Factory assembled piston and rod assemblies (that include seals for piston type specified) are recommended.

Tie Rod Torque

Bore Ø	Tie Rod Torque Series 3L
1.00	35-40 lb-in
1.50	60-70 lb-in
2.00	11-12 lb-ft
2.50	11-12 lb-ft
3.25	25-26 lb-ft
4.00	25-26 lb-ft
5.00	60-64 lb-ft
6.00	60-64 lb-ft
8.00	110-114 lb-ft

Note: The tie rod torque values are for cylinders rated at 1,000 psi. Consult factory for torque values for cylinders rated above 1,000 psi.

Parts List — 1.00" through 8.00" Bore

Symbol	Description
1	Head
7	Cap
14	Rod Gland
15	Cylinder tube
17	Piston, lipseal type
18	Cushion sleeve, rod head cushion
19	Tie rod
23	Tie rod nut
27	Retainer
37	Piston rod, single rod type
40	Rod Wiper
41	Rod Seal

Symbol	Description
42	Lipseal, piston
43	Back-up washer, rod seal
44	Back-up washer, piston
45	Gland O-ring
47	O-ring, cylinder tube to head and cap seal
69	O-ring, cushion adjustment and check valve plug screw
70	Needle, cushion adjustment valve
71	Ball, cushion check valve
72	Plug screw, cushion check valve
73	Bushing, float check, cushion on cap end
74	Retaining ring, float check cushion bushing

1.00" through 8.00" Bore

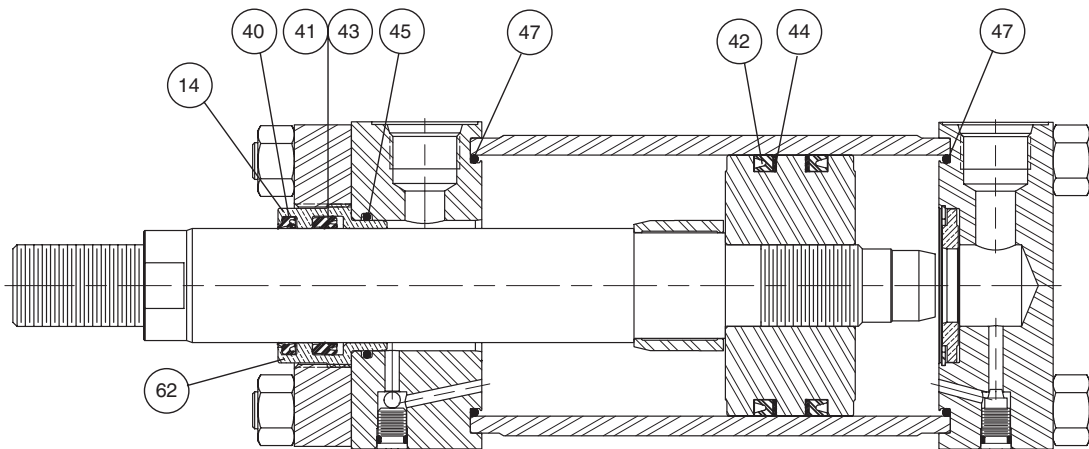

Symbol	Description
14	Rod Gland
40	Rod Wiper
41	Rod Seal
42	Piston Lipseal
43	Rod Seal Back-up Washer
44	Piston Seal Back-up Washer
45	Gland to head o-ring
47	End seal o-ring
62	Gland Cartridge Kit ¹

¹Gland Cartridge Kit contains: 14, 40, 41, 43 and 45.

Service Kit Numbers – Gland Cartridge Kits and Rod Seal Kits

Rod Ø	Seal Type			
	Class 1 Service (Polyurethane & Nitrile)		Class 2 Service ² (Nitrile)	
	Gland Cartridge Kits ¹	Rod Seal Kits ³	Gland Cartridge Kits ¹	Rod Seal Kits ³
0.500	RG2HLTS051	RK2HLTS051	RG2AHL0051	RK2AHL0051
0.625	RG2HLTS061	RK2HLTS061	RG2AHL0061	RK2AHL0061
1.000	RG2HLTS101	RK2HLTS101	RG2AHL0101	RK2AHL0101
1.375	RG2HLTS131	RK2HLTS131	RG2AHL0131	RK2AHL0131
1.750	RG2HLTS171	RK2HLTS171	RG2AHL0171	RK2AHL0171
2.000	RG2HLTS201	RK2HLTS201	RG2AHL0201	RK2AHL0201
2.500	RG2HLTS251	RK2HLTS251	RG2AHL0251	RK2AHL0251
3.000	RG2HLTS301	RK2HLTS301	RG2AHL0301	RK2AHL0301
3.500	RG2HLTS351	RK2HLTS351	RG2AHL0351	RK2AHL0351
4.000	RG2HLTS401	RK2HLTS401	RG2AHL0401	RK2AHL0401
4.500	RG2HLTS451	RK2HLTS451	RG2AHL0451	RK2AHL0451
5.000	RG2HLTS501	RK2HLTS501	RG2AHL0501	RK2AHL0501
5.500	RG2HLTS501	RK2HLTS551	RG2AHL0551	RK2AHL0551

² Series 3L rod gland cartridge kit rod seal kit, piston seal kit and body seal kit part numbers shown identify class 2 seals. To order class 5 or 6 seals substitute 5 or 6 as required for the last digit of the kit number.

³ Rod Seal Kits contain items 40, 41, 45 (43 class 2, 5 & 6 only).

⁴ Piston Lipseal Kits – (Includes Cylinder Body End Seals). Contain two each of items 47, 42, & 44.

Piston Seal Kits and Body Seal Kits

Bore Ø	Class 1 & 2 Service ²	
	Piston Lipseal Kits ⁴	Body Seal Kits
1.00	PK102HLL01	CB102HL001
1.50	PK152HLL01	CB152HL001
2.00	PK202HLL01	CB202HL001
2.50	PK252HLL01	CB252HL001
3.25	PK322HLL01	CB322HL001
4.00	PK402HLL01	CB402HL001
5.00	PK502HLL01	CB502HL001
6.00	PK602HLL01	CB602HL001
8.00	PK802HLL01	CB802HL001

Retainer Bolt Torque for Cylinders with Round Gland Retainers

Torque values are for bolts installed with lubrication.

Screw Size	Torque
# 10	56 - 58 lb-in
1/4"	11 - 12 lb-ft
5/16"	23 - 24 lb-ft
3/8"	41 - 43 lb-ft
7/16"	65 - 68 lb-ft



Notes

Section C

Custom Modifications

Metallic Rod Wiper	54
Gland Drains	54
Air Bleed Ports	54
Rod End Boots	54
Tandem and Duplex Cylinders	54
Tie Rod Supports	55
Stroke Adjusters	55
Thrust Key Mountings	55
Metric Piston Rod Thread	55
End of Stroke Proximity Switches	56
Gland Cartridge Wrenches	60

C

Series 3L Common Modifications

Modifications: The following modifications can be supplied on most Parker cylinders.

Metallic Rod Wiper

When specified metallic rod wipers can be supplied instead of the standard synthetic rubber wiperseal. Recommended in applications where contaminants tend to cling to the extended piston rod and would damage the synthetic rubber wiperseal. Installation of metallic rod wiper does not affect cylinder dimensions. It is available at extra cost.

Gland Drain

Hydraulic fluids tend to adhere to the piston rods, during the extend stroke, and an accumulation of fluid can collect in the cavity behind the gland wiperseal on long stroke cylinders.

A 1/8" NPTF gland drain port can be provided in the gland retainer. A passage in the gland between the wiperseal and lipseal is provided to drain off any accumulation of fluid between the seals. See drawing below.

It is recommended that the gland drain port be piped back to the fluid reservoir and that the reservoir be located below the level of the head of the cylinder.

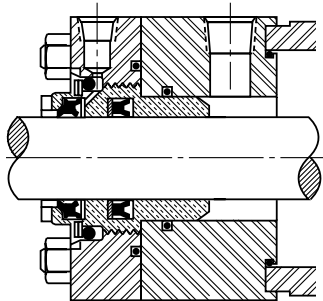

Air Bleeds

In most hydraulic circuits, cylinders are considered self-bleeding when cycled full stroke. If air bleeds are required and specified, 1/8" NPTF Air Bleed Ports for venting air can be provided at both ends of the cylinder body, or on the head or cap. To order, specify "Bleed Port", and indicate position desired.

Air Bleed Port

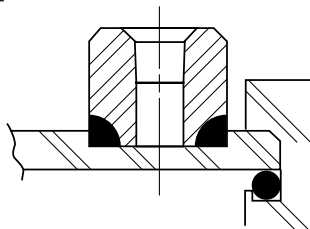

Rod End Boots

Cylinders have a hardened bearing surface on the piston rod to resist external damage, and are equipped with the high efficiency "Wiperseal" to remove external dust and dirt. Exposed piston rods that are subjected to contaminants with air hardening properties, such as paint, should be protected. In such applications, the use

Medium Duty Hydraulic Cylinders Custom Modifications

of a collapsing cover should be considered. This is commonly referred to as a "boot". Calculate the longer rod end required to accommodate the collapsed length of the boot from the following data.

LF	.13	.13	.13	.13	.13	.13	.13	.10	.10	.10	.10	.10
OD	2.25	2.25	2.63	3.00	3.38	3.75	4.38	5.13	5.63	6.25	7.00	7.50
MM	.500	.625	1.000	1.380	1.750	2.000	2.500	3.000	3.500	4.000	5.000	5.500

To determine extra length of piston rod required to accommodate boot, calculate
 $BL = \text{Stroke} \times LF + 1.125"$
 $BL + \text{Std. W} + A = \text{length of piston rod to extend beyond the retainer.}$

NOTE: Check all Boot O.D's against std. "E" dimension from catalog. This may be critical on foot mounted cylinders.

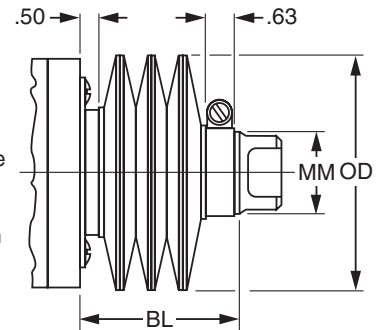

Tandem Cylinders

A tandem cylinder is made up of two cylinders mounted in line with pistons connected by a common piston rod and rod seals installed between the cylinders to permit double acting operation of each. Tandem cylinders allow increased output force when mounting width or height are restricted.

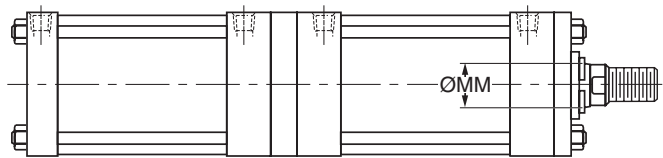

Reduced operating pressure is required for this construction. Please contact the factory.

Duplex Cylinders

A duplex cylinder is made up of two cylinders mounted in line with pistons not connected and with rod seals installed between the cylinders to permit double acting operation of each. Cylinders may be mounted with piston rod to piston (as shown) or back to back and are generally used to provide three position operation.

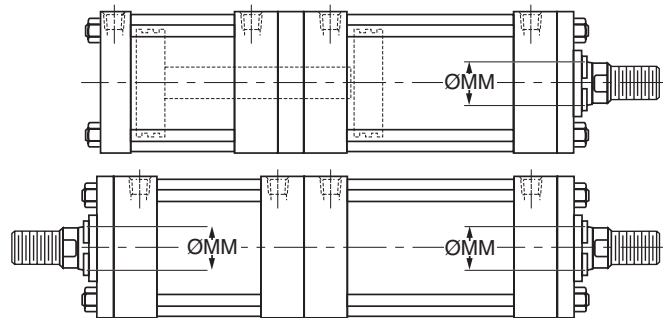

Reduced operating pressure is required for this construction. Please contact the factory.

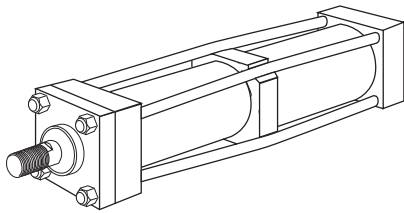

Tie Rod Supports

Rigidity of Envelope – The pre-stressed tie rod construction of Parker cylinders has advantages in rigidity within the limits of the cylinder tube to resist buckling. For long stroke cylinders within practical limits, Parker provides exclusive TIE ROD SUPPORTS (see table below) which move the tie rod centerlines radially outward.

Standard tie rod supports are kept within the envelope dimensions of the head and cap, and generally do not interfere with mounting a long cylinder.

Number of Supports Required	Bore Ø	Stroke (Inches)													
		36	48	60	72	84	96	108	120	132	144	156	168		
1.00	—	1	1	1	2	Consult Factory									
1.50	—	1	1	1	2	2	2	3	3	3	4				
2.00	—	—	—	1	1	1	1	2	2	2	2	3			
2.50	—	—	—	—	—	1	1	1	1	1	2	2			
3.25	—	—	—	—	—	—	—	1	1	1	1	1			
4.00	—	—	—	—	—	—	—	—	—	1	1	1			

Note: 5.00" through 8.00" bore sizes — no supports required.

Stroke Adjusters

For the requirement where adjusting the stroke is specified. Parker has several designs to offer, one of which is illustrated below. This is suitable for infrequent adjustment and is economical¹.

Bore Ø Series 3L	D	J	K	L (Max.)
1.50, 2.00	1/2 - 20	0.31	0.94	5.00
2.50, 3.25, 4.00	3/4 - 16	0.44	1.25	8.00
5.00, 6.00	1 - 14	0.63	1.69	9.00
8.00	1 1/2 - 12	0.94	2.13	18.00

Here a “retracting stroke adjuster” must be called for in specifications, and the length of the adjustment must be specified.

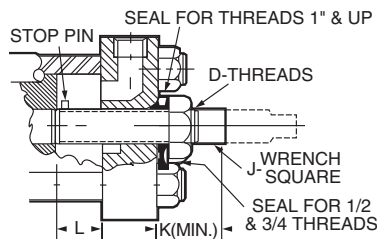

Where frequent adjustment or cushions at the cap end are required, other designs are available according to application needs.

¹Infrequent is defined by positioning the retract stroke in a couple of attempts at original machine set up. The frequent stroke adjuster is recommended for adjustments required after the original equipment has been adjusted by the original machine manufacturer.

Thrust Key Mountings

Thrust key mountings eliminate the need of using fitted bolts or external keys on side mounted cylinders. Parker cylinders in mounting styles CP and FP can be provided with the gland retainer plate extended below the mounting side of the cylinder (see illustration below). This extended retainer plate can then be fitted into a keyway milled into the mounting surface of the machine member. This is referred to as the “P” Modification of any side mounting style.

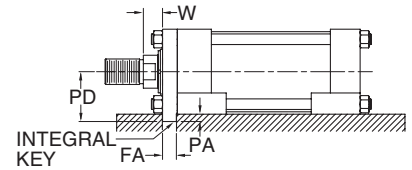

Bore Ø	FA	PA	PD Mtg. Styles CP & FP
1.00	.312 ^{-.002} / _{+.000}	0.19	0.94
1.50	.312 ^{-.002} / _{+.000}	0.19	1.19
2.00	.312 ^{-.002} / _{+.000}	0.19	1.44
2.50	.312 ^{-.002} / _{+.000}	0.19	1.69
3.25	.562 ^{-.002} / _{+.000}	0.31	2.19
4.00	.562 ^{-.002} / _{+.000}	0.31	2.56
5.00	.562 ^{-.002} / _{+.000}	0.31	3.06
6.00	.687 ^{-.002} / _{+.000}	0.38	3.63

Metric Piston Rod Thread

The table below lists the standard thread supplied when Piston Rod Thread type M is specified in the cylinder model code.

MM Rod Ø	Thread		A
	Styles 4M & 9M KK	Style 8M CC	
0.625	M10x1.5	M12x1.5	0.75
1.000	M20x1.5	M22x1.5	1.13
1.375	M26x1.5	M30x2	1.63
1.750	M33x2	M39x2	2.00
2.000	M39x2	M45x2	2.25
2.500	M48x2	M56x2	3.00
3.000	M58x2	M68x2	3.50
3.500	M64x2	M76x2	3.50
4.000	M76x2	M95x2	4.00
4.500	M80x2	M110x2	4.50
5.000	M90x2	M110x2	5.00
5.500	M100x2	M130x2	5.50



Cylinder End-of-Stroke Proximity Switches



“EPS” Style Inductive Sensors
For General Industrial AC and DC Applications

“CLS” Style Magnetic Sensors
Including Extreme Temperature Applications

All Sensors Are:
Non-Contacting
Water Resistant
Weld-Field Immune
Shock and Vibration Resistant
Flange-Mounted to Cylinder End Caps

**EPS 7 & 6 Sensors
Inductive Proximity**

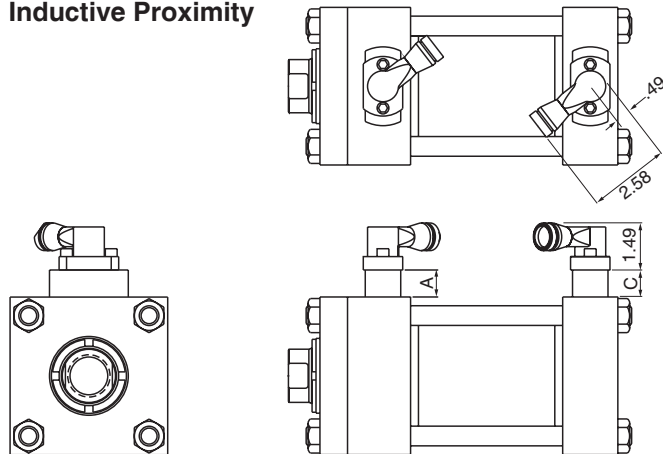

**CLS 1 & 4 Sensors
Non-Contacting
Magnetically
Actuated**

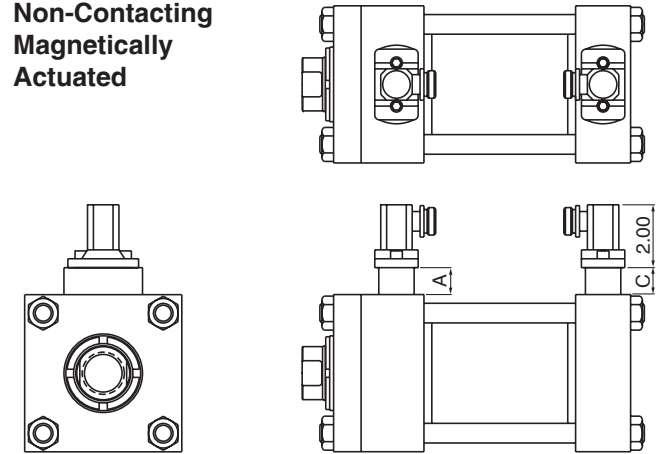

**Spacer Height
EPS & CLS Sensors**

A max.	C max.
1.55	1.05

For exact dimensions, see Bulletin 0840-G-E1.

Connector Pin Numbering

3-Pin Mini

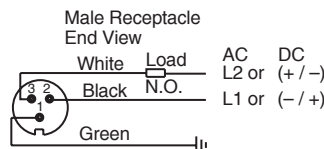

EPS-7

5-Pin Mini

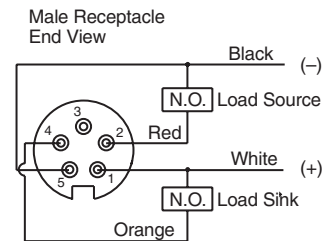

EPS-6

Series and Parallel Wiring

When Parker EPS-6 or 7 sensors are used as inputs to programmable controllers the preferred practice is to connect each sensor to a separate input channel of the PLC. Series or parallel operations may then be accomplished by the internal PLC programming.

EPS-6 or 7 sensors may be hard wired for series operation, but the voltage drop through the sensors (see specifications) must not reduce the available voltage below what is needed to actuate the load.

EPS-6 or 7 sensors may also be hard wired for parallel operation. However, the leakage current of each sensor will pass through the load. The total of all leakage currents must not exceed the current required to actuate the load. In most cases, the use of two or more EPS-6 or 7 sensors in parallel will require the use of a bypass (shunt) resistor.

Minimum Stroke

The minimum stroke for EPS-6 or 7 and CLS-1 or 4 sensors, utilizing standard components, is the cushion sleeve or spear length for the cylinder series in which the sensor is installed. See the individual Industrial Cylinder series catalog for cushion length details. Contact the factory if a shorter stroke is required.



Specifications				
Style:	EPS-7	EPS-6	CLS-1	CLS-4
Code Designator:	H	D	F	B
Description:	Economical, General Purpose, 2 wire device, primarily for AC applications. (Not suitable for 3 wire 24 volt Sinking or Sourcing applications.) Also for automotive industry applications.	Economical, General Purpose, 3 wire, DC sensor, dual output: sinking and sourcing	Functional replacement for AB (Mechanical) Limit Switches in many applications, or where customer needs NC contacts, zero leakage, zero voltage drop, higher or lower load current than EPS-style	Functional replacement for AB (Mechanical) Limit Switches in many High Temperature applications, or where customer needs NC contacts, zero leakage, zero voltage drop, higher or lower load current than EPS-style.
Supply Voltage:	20 to 250 VAC/DC	10 to 30 VDC	24 to 240 VAC/DC	24 to 240 VAC/DC
Load Current, min:	8 mA	N/A	NA	NA
Load Current, max:	300 mA	200 mA	4 AMPS @ 120 VAC 3 AMPS @ 24VDC	4 AMPS @ 120 VAC 3 AMPS @ 24 VDC
Leakage Current:	1.7 mA, max.	10 micro amps max	–	–
Voltage Drop:	7 V, max.	2 VDC max.	N/A	NA
Operating Temperature:	-14° to +158° F	-14° to +158°F	-40°F to +221°F	-40°F to +400°F
Sensor Type:	Inductive proximity	Inductive proximity	non-contacting magnetically actuated	non-contacting magnetically actuated
Part Number:	148897 ¹	148896 ¹	148275 ¹	149109 ¹
Part Number Suffix¹:	¹4-digit suffix indicates probe length: 0125=1.25", 0206=2.06", 0288=2.875", 0456=4.562"			
Connection:	3 pin mini	5 pin mini	3 pin mini	144" PTFE Coated Flying Leads with 1/2" conduit hub
Enclosure Rating:	IEC IP67	IEC IP67	NEMA 1, 2, 3, 4, 4x, 5, 6, 6P, 11, 12, 12K, 13	NEMA 1, 2, 3, 4, 4x, 5
LED indication:	Yes	Yes	Yes	No
Short Circuit Protection:	Yes	Yes	No	No
Weld Field Immunity:	Yes	Yes	Yes	Yes
Output:	2 wire, Normally Open with leakage current	Dual Output: DC Sinking and DC Sourcing, user selectable via wiring	SPDT (Single Pole Double Throw), Normally Open/Normally Closed, Form C	SPDT (Single Pole Double Throw), Normally Open/Normally Closed, Form C
Approvals/Marks:	CE, UL, CSA	CE, UL, CSA	UL or CSA ²	UL or CSA ²
Make/Break Location:	0.13" from end of stroke, typical. Tolerance is +0"/-.13"			
Wiring Instructions:	Pin 1: AC Ground (Green) Pin 2: Output (Black) Pin 3: AC Line (White)	Pin 1) +10 to 30 VDC (White) Pin 2) Sourcing Output (Red) Pin 3) Grounded (not connected or required) Pin 4) Sinking Output (Orange) Pin 5) DC Common (Black)	Pin 1: Common (Green) Pin 2: Normally Closed (Black) Pin 3: Normally Open (White)	Common: (Black) Normally Open: (Blue) Normally Closed: (Red)
Cable: 6'	0853550006	0859170006	0853550006	–
Cable: 12'	0853550012	0859170012	0853550012	–
Cable: 6', Right Angle	0875470006	–	0875470006	–

²CSA available upon request – contact factory.

How to Specify EPS Proximity Switches

Parker EPS proximity switches may be ordered on Series 3L cylinders as follows:

- 1) Complete the basic cylinder model number.
- 2) Place an "S" in the model number to denote switches and/or special features.
- 3) Mounting styles D, DB, JJ, J, or H should be used with caution because of possible mounting interferences. Consult bulletin 0840-G-E1 for additional information.
- 4) Special modifications to cylinders other than switches must have a written description.

5) Specify letter prefix "H" for EPS-7, "D" for EPS-6, and "F" for CLS-1, or "B" for CLS-4, then fill in the four blanks specifying port location, switch orientation and actuation point for both head and cap. If only one switch is used, place "XXXX" in the unused blanks.

Example = H13AGG-XXXX denotes a switch on the head end only, EPS-7

Example = XXXX-H42AGG denotes a switch on the cap end only, EPS-7

Head End

H	1	3	A	GG
Specify: "H" = EPS-7 "D" = EPS-6 "F" = CLS-1 ¹ "B" = CLS-4 ¹ "N" = Prep for switches only	Port Location See Figure 1.	Switch Location See Figure 1.	Switch Orientation See Figure 2 for CLS-1, CLS-4, EPS-6 and EPS-7 only.	Actuation Point GG = End of Stroke FF = Stroke to Go; See Bulletins 0840-G-E1, 2 or 3 for stroke remaining.

Cap End

H	4	2	A	GG
Specify: "H" = EPS-7 "D" = EPS-6 "F" = CLS-1 "B" = CLS-4 "N" = Prep for switches only	Port Location See Figure 1.	Switch Location See Figure 1.	Switch Orientation See Figure 2 for CLS-1, CLS-4, EPS-6 and EPS-7 only.	Actuation Point GG = End of Stroke FF = Stroke to Go; See Bulletins 0840-G-E1, 2 or 3 for stroke remaining.

Note: All specified switch and port locations are as seen from rod end of cylinder.

¹ CLS-1 and CLS-4 proximity switches are not available on the head end of 1.50" bore with 1.00" rod and 2.00" bore with 1.375" rod

Figure 1

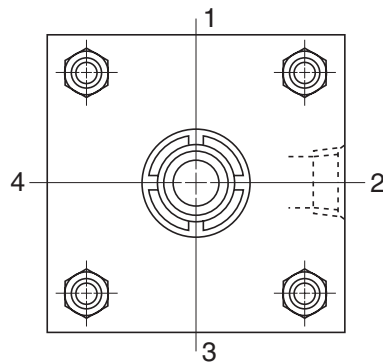
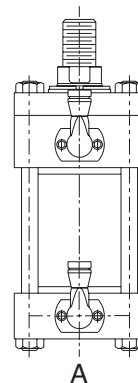

Figure 2



Gland Cartridge Wrenches

Parker's exclusive gland cartridge design makes gland replacement only a minute's work...and the Gland Cartridge Wrench Set makes it even simpler. A specially designed face-type gland wrench with flared lugs slips into an exact, sure fit on the gland, while a self-locking spanner wrench grips the gland wrench securely. No fumbling for adjustment – no accidental scoring of the piston rod, the job is done quickly...easily...safely.

You can order the Cartridge Wrench or Spanner Wrench to fit the piston rod size used in your Parker Hannifin Cylinder.

See chart below.

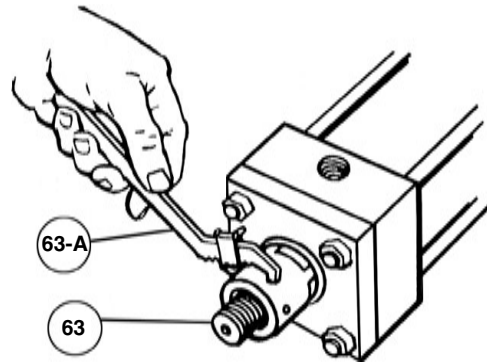

Rod Diameter	Gland Wrench (Symbol 63)	Spanner Wrench (Symbol 63-A)
5/8"	0695900000	0116760000
1"	0695910000	
1 3/8"	0695920000	0117030000
1 3/4"	0695930000	0116770000
2"	0695940000	
2 1/2"	0695950000	0116770000
3"	0695960000	
3 1/2"	0695970000	
4"	0695980000	0116780000
4 1/2"	0837770000	
5"	0695990000	
5 1/2"	0696000000	

Section D

.....

Engineering Data

Theoretical Push and Pull Forces	62
Cylinder Weights	64
Operating Fluids and Temperature Range	65
Pressure Ratings	66
Ports	67
Stroke Data, Stop Tube and Mounting Classes	70
Piston Rod Selection Chart	71
Spherical Bearing Mount Application	73
Cushioning	74
Cylinder Safety Guide	75
Regional Plant Locations	79
Offer of Sale	80

D

Theoretical Push Forces for Hydraulic Cylinders — Push Force

Bore Ø	Piston Area (Sq. In.)	Cylinder Push Stroke Force in Pounds at Various Pressures					
		100	250	500	1000	1500	2000
1.00	0.79	79	196	392	785	1178	1570
1.50	1.767	177	443	885	1770	2651	3540
2.00	3.14	314	785	1570	3140	4712	6280
2.50	4.91	491	1228	2455	4910	7363	9820
3.25	8.30	830	2075	4150	8300	12444	16600
4.00	12.57	1257	3143	6285	12570	18850	25140
5.00	19.64	1964	4910	9820	19640	29453	39280
6.00	28.27	2827	7068	14135	28270	42412	56540
8.00	50.27	5027	12568	25135	50270	75398	100540

General Formula

The cylinder output forces are derived from the formula:

$$F = P \times A$$

Where F = Force in pounds.

P = Pressure at the cylinder in
pounds per square inch, gauge.

A = Effective area of cylinder piston
in square inches.

Theoretical Pull Forces for Hydraulic Cylinders

Bore Ø	Piston Rod Ø	Piston Rod Area (Sq. In.)	Cylinder Pull Force in Pounds at Various Pressures					
			100	250	500	1000	1500	2000
1.00	0.500	0.196	59	149	297	594	891	1188
	0.625	0.307	48	121	242	483	725	966
1.50	0.625	0.307	146	365	730	1460	2190	2920
	1.000	0.785	98	245	491	982	1473	1964
2.00	0.625	0.307	283	708	1417	2833	4250	5666
	1.375	1.48	166	415	830	1660	2490	3320
	1.000	0.785	236	589	1178	2355	3533	4710
2.50	1.000	0.785	413	1031	2063	4125	6188	8250
	1.750	2.41	250	625	1250	2500	3750	5000
	1.375	1.48	343	858	1715	3430	5145	6860
	0.625	0.307	460	1151	2302	4603	6905	9206
3.25	1.000	0.785	752	1879	3758	7515	11273	15030
	2.000	3.14	516	1290	2580	5160	7740	10320
	1.375	1.48	682	1705	3410	6820	10230	13640
	1.750	2.41	589	1473	2945	5890	8835	11780
4.00	1.375	1.48	1109	2773	5545	11090	16635	22180
	2.500	4.91	766	1915	3830	7660	11490	15320
	1.750	2.41	1016	2540	5080	10160	15240	20320
	2.000	3.14	943	2358	4715	9430	14145	18860
	1.000	0.785	1179	2946	5893	11785	17678	23570
5.00	1.750	2.41	1723	4308	8615	17230	25845	34460
	3.500	9.62	1002	2505	5010	10020	15030	20040
	2.000	3.14	1650	4125	8250	16500	24750	33000
	2.500	4.91	1473	3683	7365	14730	22095	29460
	3.000	7.07	1257	3143	6285	12570	18855	25140
	1.000	0.785	1886	4714	9428	18855	28283	37710
	1.375	1.48	1816	4540	9080	18160	27240	36320
6.00	1.750	2.41	2586	6465	12930	25860	38790	51720
	4.000	12.57	1570	3925	7850	15700	23550	31400
	2.000	3.14	2513	6283	12565	25130	37695	50260
	2.500	4.91	2336	5840	11680	23360	35040	46720
	3.000	7.07	2120	5300	10600	21200	31800	42400
	3.500	9.62	1865	4663	9325	18650	27975	37300
	1.375	1.48	2679	6698	13395	26790	40185	53580
8.00	2.000	3.14	4713	11783	23565	47130	70695	94260
	5.500	23.76	2651	6628	13255	26510	39765	53020
	2.500	4.91	4536	11340	22680	45360	68040	90720
	3.000	7.07	4320	10800	21600	43200	64800	86400
	3.500	9.62	4065	10163	20325	40650	60975	81300
	4.000	12.57	3770	9425	18850	37700	56550	75400
	1.375	1.48	4879	12198	24395	48790	73185	97580
	1.750	2.41	4786	11965	23930	47860	71790	95720
	4.500	15.90	3437	8593	17185	34370	51555	68740
	5.000	19.63	3064	7660	15320	30640	45960	61280



The weights shown below are for standard Series 3L hydraulic cylinders equipped with various diameter piston rods. To determine the net weights of a cylinder, first select the proper basic weight for zero stroke, then calculate the weight of the cylinder stroke and add the result to the basic weight. For extra rod extension use

piston rod weights per inch shown in Table B. Weights of cylinders with intermediate rods may be estimated from table below by taking the difference between the piston rod weights per inch and adding it to the Code 1 weight for the cylinder bore size involved.

Table A Cylinder Weights, in pounds, for Series 3L hydraulic cylinders

Bore Ø	Rod Ø	Single Rod Cylinders Basic Wt. Zero Stroke		Add Per Inch of Stroke	Double Rod Cylinders Basic Wt. Zero Stroke		Add Per Inch of Stroke
		F, H, J, T, TB, TC, TD	BB, C, D, DB, DD, HB, JB		KJ, KF, KT, KTD, KTB	KJB, KC, KD, KDD	
1.00	0.500	2.5	2.9	0.20	4.7	5.5	0.40
	0.625	2.6	3.0	0.23	4.9	5.7	0.46
1.50	0.625	3.7	4.3	0.3	4.2	4.8	0.6
	1.000	4.5	5.1	0.4	5.8	6.7	0.8
2.00	0.625	6.5	6.9	0.5	8.2	8.6	1.0
	1.000	7.0	7.5	0.63	9.0	9.5	1.3
	1.375	8.5	8.9	0.8	11.2	11.6	1.6
2.50	0.625	9.0	9.7	0.6	11.4	12.1	1.2
	1.000	9.5	10.0	0.73	12.0	12.5	1.5
	1.750	13.2	13.6	1.1	19.8	20.5	2.2
3.25	1.000	16.5	17.5	0.8	22.0	23.0	1.6
	1.375	17.0	18.0	1.0	22.5	23.5	2.0
	2.000	27.0	28.0	1.4	43.0	44.0	2.8
4.00	1.000	26.0	31.0	1.0	33.0	38.0	2.0
	1.375	26.5	31.5	1.2	33.5	38.5	2.5
	2.500	36.0	42.0	2.0	53.0	58.0	4.0
5.00	1.000	39.0	46.0	1.1	48.0	55.0	2.2
	1.375	39.5	46.5	1.3	48.5	55.5	2.6
	3.500	63.0	66.0	3.6	96.0	103.0	7.2
6.00	1.375	68.0	77.0	1.5	80.0	89.0	3.0
	4.000	100.0	102.0	4.5	144.0	153.0	9.0
8.00	1.375	94.0	99.0	2.0	108.0	113.0	4.0
	5.500	168.0	172.0	8.0	256.0	261.0	16.0

Table B Piston Rod Weights, in pounds, for Series 3L hydraulic cylinders

Rod Ø	Piston Rod Wt. Per Inch	Rod Ø	Piston Rod Wt. Per Inch	Rod Ø	Piston Rod Wt. Per Inch
0.625	0.09	2.000	0.89	4.000	3.56
1.000	0.22	2.500	1.40	4.500	4.51
1.375	0.42	3.000	2.00	5.000	5.56
1.750	0.68	3.500	2.72	5.500	6.72

Operating Fluids and Temperature Range

Fluidpower cylinders are designed for use with pressurized air, hydraulic oil and fire resistant fluids, in some cases special seals are required.

Standard Seals (class 1)

Class 1 seals are what is normally provided in a cylinder unless otherwise specified. They are intended for use with fluids such as: air, nitrogen, mineral base hydraulic oil or MIL-H-5606 within the temperature range of -10°F (-23°C) to +165°F (+74°C). Generally they are nitrile except for piston rod seals in hydraulic cylinders. However the individual seals may be nitrile (Buna-N) enhanced polyurethane, polymyte, P.T.F.E. or filled P.T.F.E.

Water Base Fluid Seals (class 2)

Generally class 2 seals are intended for use with water base fluids within the temperature of -10°F (-23°C) to +165°F (+74°C) except for High Water Content Fluids (H.W.C.F.) in which case Class 6 seals should be used. Typical water base fluids are: Water, Water-Glycol, Water-in Emulsion, Houghto-Safe 27, 620, 5040, Mobil Pyrogard D, Shell Iruis 905, Ucon Hydrolube J-4. These seals are nitrile. Lipseal will have polymyte or P.T.F.E. back-up washer when required. O-rings will have nitrile back-up washers when required.

Ethylene Propylene (E.P.R.) Seals (class 3)

Class 3 seals are intended for use with some Phosphate Ester Fluids between the temperatures of -10°F (-23°C) to +130°F (+54°C). Typical fluids compatible with E.P.R. seals are Skydrol 500 and 700. E.P.R. are Ethylene Propylene. Lipseals will have a P.T.F.E. back-up washer when required. O-rings will have EPR back-up washers when required.

Note: E.P.R. seals are not compatible with mineral base hydraulic oil or greases. Even limited exposure to these fluids will cause severe swelling. P.T.F.E. back-up washer may not be suitable when used in a radiation environment.

Low Temperature Nitrile Seals (class 4)

Class 4 seals are intended for low temperature service with the same type of fluids as used with Class 1 seals within the temperature range of -50°F (-46°C) to +150°F (+66°C). Lipseals will have leather, polymyte or P.T.F.E. back-up washers when required. O-rings will have nitrile back-up washers when required. **Note:** Certain fluids may react adversely with Class 4 seals compared to Class 1 seals.

Fluorocarbon Seals (class 5)

Class 5 seals are intended for elevated temperature service or for some Phosphate Ester Fluids such as Houghto-Safe 1010, 1055, 1120; Fyrquel 150, 220, 300, 350; Mobile Pyrogard 42, 43, 53, and 55. **Note:** In addition, class 5 seals can be used with fluids listed below under standard service. However, they are not compatible with Phosphate Ester Fluids such as Skydrols. Class 5 seals can operate with a temperature range of -10°F (-23°C) to +250°F (+121°C). Class 5 seals may be operated to +400°F (+204°C) with limited service life. For temperatures above +250°F (+120°C) the cylinder must be manufactured with non-studded piston rod and thread and a pinned piston to rod connection. Class 5 Lipseals will have P.T.F.E. back-up washers when required. O-rings will have fluorocarbon back-up when required.

H.W.C.F. Seals (class 6)

Class 6 seals are intended for High Water Content Fluids (H.W.C.F.) such as Houghto Hydrolubric 120B and Sonsol Lubrizol within the temperature range of +40°F (+4°C) to +120°F (+49°C). Class 6 seals are special nitrile compound dynamic seals. Lipseals will have P.T.F.E. and or polymyte back-up washers when required. O-rings will have nitrile

back-up washers when required. Because of the viscosity of these fluids, cylinders specified with class 6 seals, will also be modified to have lip seal piston seals and straight cushions.

Energized PTFE Seals (class 8)

Class 8 seals consist of PTFE piston lipseals, rod seal and wiperseal. Piston seals have an internal stainless steel spring to energize both the static and dynamic sealing lips. They are intended for high temperature applications, to 400° F (204° C), where longer seal life and improved high temperature sealing performance is required. Body and gland o-ring seals will be fluorocarbon. Fluid resistance is comparable to Class 5.

Warning ⚠

The piston rod stud and the piston rod to piston threaded connections are secured with an anaerobic adhesive which is temperature sensitive. Cylinders are assembled with anaerobic adhesive having a maximum temperature rating of +250°F (+74°C). Cylinders specified with all other seal compounds (built before 1997) were assembled with anaerobic adhesive having a maximum operating temperature rating +165°F (+74°C). These temperature limitations are necessary to prevent the possible loosening of the threaded connections. Cylinders originally manufactured (before 1997) with class 1 seals (Nitrile) that will be exposed to ambient temperatures above +165°F (+74°C) must be modified for higher temperature service. Contact the factory immediately and arrange for the piston to rod and the stud to piston rod connections to be properly re-assembled to withstand the higher temperature service.

Lipseal Pistons

Under most conditions lipseals provide the best all around service for pneumatic applications. Lipseals with a back-up washer are often used for hydraulic applications when virtually zero static leakage is required. Lipseals will function properly in these applications when used in conjunction with moderate hydraulic pressures. A high load piston option is recommended when operating at high pressures and especially with large bore hydraulic cylinders.

Water Service

Series 3L cylinders can be modified to make them more suitable for use with water as the operating medium. The modifications include chrome-plated cylinder bore; electroless nickel-plated head, cap and piston; chrome-plated 17-4 stainless steel piston rod; chrome plated cushion sleeve or cushion spear.

Modified cylinders may also be used for higher operating pressures, up to 2000 psi, depending on bore size. See pressure rating for Hydraulic Cylinders on the next page. Series 3L hydraulic cylinders can also be modified for water operation and supplied with chrome-plated cylinder bore; electroless nickel-plated head, cap and piston; chrome-plated precipitation hardened stainless steel piston rod, chrome-plated cushion sleeve or cushion spear. When high water base fluids are the operating medium, hydraulic cylinders are usually supplied with high water base rod wiper and seals. Water and high water base fluid operated cylinders are best used on short stroke applications or where high pressure is applied only to clamp the load.

Warranty

Parker Hannifin will warrant cylinders modified for water or high water content fluid service to be free of defects in materials or workmanship, but cannot accept responsibility to premature failure due to excessive wear due to lack of lubricity or where failure is caused by corrosion, electrolysis or mineral deposits within the cylinder.

Fluids and Temperature Range

Class No.	Typical Fluids	Temperature Range
1 (Standard) (Nitrile Polyurethane)	Air, Nitrogen Hydraulic Oil, Mil-H-5606 Oil	-10°F (-23°C) to +165°F (+74°C)
2 Optional Water Base Fluid Seal	Water, Water-Glycol, H.W.C.F. — See Class 6 below. Water-in-Oil Emulsion Houghto-Safe, 271, 620, 5040. Mobil Pyrogard D, Shell IruS 905. Ucon Hydrolube J-4	-10°F (-23°C) to +165°F (+74°C)
3 Special (E.P.R.) (At extra cost)	Some Phosphate Ester Fluids Skydrol 500, 7000	-10°F (-23°C) to +130°F (+54°C)
Note: (E.P.R.) seals are not compatible with Hydraulic Oil		
4 Special (Nitrile) (At extra cost)	Low Temperature Air or Hydraulic Oil	-50°F (-46°C) to +150°F (+66°C)
5 Optional (At extra cost) (Fluorocarbon Seals)	High Temperature Houghto-Safe 1010, 1055, 1120 Fyrquel 150, 220, 300, 550 Mobil Pyrogard 42,43,53,55	See paragraph on Fluorocarbon seals for recommended temperature range.
Note: Fluorocarbon seals are not suitable for use with Skydrol fluid, but can be used with hydraulic oil if desired.		
6 Optional (HWCF) (At extra cost)	Houghton, Hydrolubric 120B Sonsol Lubrizol, for other HWCF — consult factory.	+40°F (+4°C) to +120°F (+49°C)
8 Optional (At extra cost) Energized PTFE	See Class 5 Seals	-15°F (-26°C) to 400°F (204°C)

Application Data

The proper application of a fluid power cylinder requires consideration of the operating pressure, the fluid medium, the mounting style, the length of stroke, the type of piston rod connection to the load, thrust or

tension loading on the rod, mounting attitude, the speed of stroke, and how the load in motion will be stopped. Information given here provides pressure rating data for pneumatic and hydraulic cylinders.

Pressure Ratings

Pressure ratings for Series 3L hydraulic cylinders vary by bore size and rod size as shown in the table. For pressures

higher than those indicated, Series 2H heavy duty cylinders should be used.

Series 3L Hydraulic Cylinders Maximum Pressure Rating

Bore Ø	Rod No.	Rod Ø	Pressure Rating At 4:1 Design ¹ Factor (On Tensile)
1.00	1	0.500	1900
	2	0.625	1900
1.50	1	0.625	2000
	2	1.000	2300
2.00	1	0.625	1100
	3	1.000	2000
	2	1.375	2000
2.50	7	0.625	700
	1	1.000	1400
	3	1.375	1400
3.25	2	1.750	1400
	1	1.000	1300
	3	1.375	1300
	4	1.750	1300
4.00	2	2.000	1300
	7	1.000	900
	1	1.375	900
	3	1.750	900
	4	2.000	900
	2	2.500	900

Bore Ø	Rod No.	Rod Ø	Pressure Rating At 4:1 Design ¹ Factor (On Tensile)
5.00	7	1.000	600
	8	1.375	950
	1	1.750	950
	3	2.000	950
	4	2.500	950
	5	3.000	950
6.00	2	3.500	950
	7	1.375	700
	1	1.750	700
	3	2.000	700
	4	2.500	700
	5	3.000	700
8.00	6	3.500	700
	2	4.000	700
	7	1.375	400
	8	1.750	650
	1	2.000	650
	3	2.500	650
	4	3.000	650
	5	3.500	650
	6	4.000	650
	9	4.500	650
0	5.000	650	
2	5.500	650	

¹ Applies to all mountings except J.



Ports

Series 3L cylinders can be supplied with S.A.E. straight O-ring ports or NPTF pipe thread ports. If specified on your order, extra ports can be provided on the sides of heads or caps that are not occupied by mountings or cushion valve.

Standard port location is position 1 as shown on line drawings in product catalog and Figure 1 below. Cushion adjustment needle and check valves are at positions 2 and 4 (or 3), depending on mounting style. Heads or caps which do not have an integral mounting can be rotated and assembled with ports at 90° or 180° from standard position. Mounting styles on which head or cap can be rotated at no extra charge are shown in Table A below. To order, specify by position number. In such assemblies the cushion adjustment needle and check valve rotate accordingly, since their relationship with port position does not change.

Figure 1

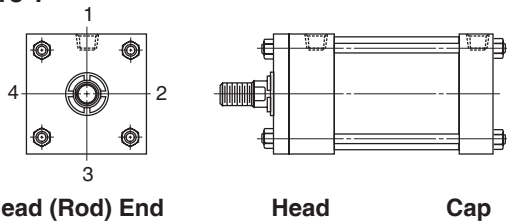

Cylinder Port Options

- Option “T” SAE Straight Thread O-Ring Port. Recommended for most hydraulic applications.
- Option “U” Conventional NPTF Ports (Dry-Seal Pipe Threads). Recommended for pneumatic applications only.
- Option “R” BSPP Port (British Parallel Thread). ISO 228 port commonly used in Europe.
- Option “B” BSPT (British Tapered Thread).
- Option “G” Metric Straight Thread Port similar to Option “R” with metric thread. Popular in some European applications.
- Option “Y” ISO-6149-1 Metric Straight Thread Port. Recommended for all hydraulic applications designed per ISO standards.

Table A

Mounting Style	Port Position Available	
	Head End	Cap End
T, TB, TC, TD, H, HB, J, JB, DD	1, 2, 3 or 4	1, 2, 3 or 4
BB, DB, SB	1,2, 3 or 4	1 or 3
D, JJ	1 or 3	1, 2, 3 or 4
C, F	1	1

Ports can be supplied at positions other than those shown in Table A at an extra charge. To order, specify port position as shown in Figure 1.

Available Ports for Series 3L Cylinders

Bore Ø	“T” SAE Straight Thread	“U” NPTF Pipe Thread	“R” BSPP Parallel Thread	“B” BSPT Taper Thread	“G” Metric Straight Thread	“Y” ISO-6149-1 Metric Straight Thread
1.00	#6	1/4	1/4	1/4	M14 x 1.5	M14 x 1.5 ¹
1.50	#6	3/8	3/8	3/8	M14 x 1.5	M14 x 1.5 ¹
2.00	#6	3/8	3/8	3/8	M14 x 1.5	M14 x 1.5
2.50	#6	3/8	3/8	3/8	M14 x 1.5	M14 x 1.5
3.25	#10	1/2	1/2	1/2	M22 x 1.5	M22 x 1.5
4.00	#10	1/2	1/2	1/2	M22 x 1.5	M22 x 1.5
5.00	#10	1/2	1/2	1/2	M22 x 1.5	M22 x 1.5
6.00	#12	3/4	3/4	3/4	M26 x 1.5	M27 x 2
8.00	#12	3/4	3/4	3/4	M26 x 1.5	M27 x 2

¹ Not available on code 2 rods



Oversize Ports

Oversize NPTF or SAE straight thread ports can be provided, at an extra charge. For ports one size larger than standard, welded port bosses which protrude from the side of the head or cap are supplied. For dimensions, see drawings and tables below. Series 3L cylinders equipped with cushions at the cylinder cap end can sustain damage to the cushion check valve (cushion bushing) if excessive oil flow enters the cylinder from the cap end port. Cylinders which are equipped with cap end cushions and ordered with one size oversize ports having hydraulic fluid flow exceeding 25 ft./sec. in the line entering the cap end of the cylinder should be ordered with a “solid cushion” at cap end. All cylinders ordered with double oversize ports should always be ordered with a “solid cushion” at cap end.

Cylinders which are connected to a meter out flow control with flow entering the cap end of a cylinder provided by an accumulator may also experience damage to the cushion bushing due to high instantaneous fluid flows. This condition can be eliminated by using a meter in flow control or “solid cushions” at cap end.

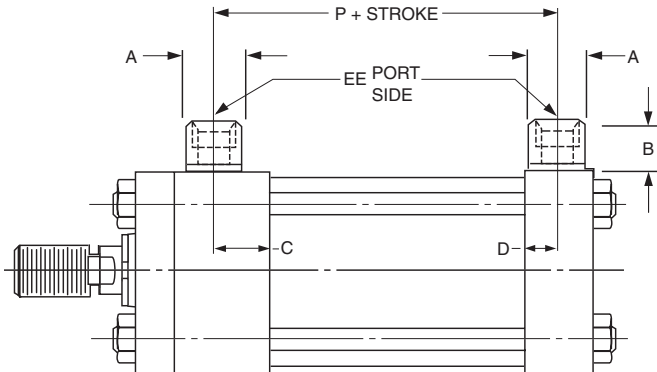

Oversize NPTF Port Boss Dimensions

Bore Ø	EE (NPTF)	A Ø	B	C	D	P
1.00	3/8	0.88	0.75	0.56	0.50	2.06
1.50	1/2	1.13	0.94	0.56	0.50	2.19
2.00	1/2	1.13	0.94	0.56	0.50	2.19
2.50	1/2	1.13	0.94	0.56	0.50	2.31
3.25	3/4	1.38	1.00	0.69	0.63	2.56
4.00	3/4	1.38	1.00	0.69	0.63	2.56
5.00	3/4	1.38	1.00	0.69	0.63	2.81
6.00	1	1.75	1.19	0.94	0.75	3.19
8.00	1	1.75	1.19	0.94	0.75	3.31

Oversize SAE Straight Thread Port Boss Dimensions

Bore Ø	EE (SAE)	A Ø	B	C	D	P
1.00	8	1.13	0.94	0.56	0.50	2.06
1.50	8	1.13	0.94	0.56	0.50	2.19
2.00	8	1.13	0.94	0.56	0.50	2.19
2.50	8	1.13	0.94	0.56	0.50	2.31
3.25	12	1.38	1.00	0.69	0.63	2.56
4.00	12	1.38	1.00	0.69	0.63	2.56
5.00	12	1.38	1.00	0.69	0.63	2.81
6.00	16 ¹	1.75	1.19	0.94	0.75	3.19
8.00	16 ¹	1.75	1.19	0.94	0.75	3.31

¹ Available at head end only. For cap end, consult factory.

Manifold Ports

Side mounted cylinders, Style C can be furnished with the cylinder ports arranged for mounting and sealing to a manifold surface. The ports are drilled and counterbored for O-ring seals which are provided. With these specifications, the mounting is designated Style CM or KCM.

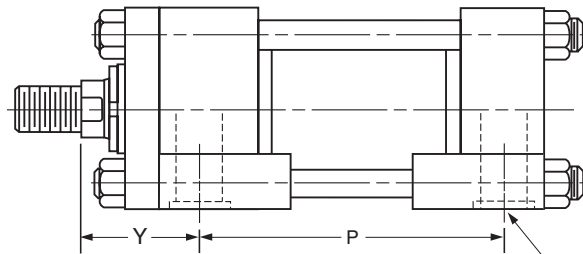

**Dimensions —
Manifold Ports for Single and Double Rod Cylinders**

Bore Ø	Rod Code	Rod Ø	Y ±.031	P ±.031	EE	ED
1.00	All	All	1.94	2.13	.38	.69
1.50	1	.625	2.00	2.13	.50	.81
	2	1.000	2.38			
2.00	1	.625	2.00	2.13	.50	.81
	2	1.375	2.63			
	3	1.000	2.38			
2.50	1	.625	2.00	2.25	.50	.81
	2	1.750	2.88			
	3	1.000	2.38			
	4	1.375	2.63			
3.25	1	1.000	2.44	2.63	.63	.94
	2	2.000	3.06			
	3	1.375	2.69			
	4	1.750	2.94			
4.00	1	1.000	2.44	2.63	.63	.94
	2	2.500	3.31			
	3	1.375	2.69			
	4	1.750	2.94			
	5	2.000	3.06			
5.00	1	1.000	2.44	2.88	.63	.94
	2, 6 & 7	3.500, 2.500 & 3.000	3.31			
	3	1.375	2.69			
	4	1.750	2.94			
	5	2.000	3.06			

Bore Ø	Rod Code	Rod Ø	Y ±.031	P ±.031	EE	ED
6.00	1	1.380	2.81	3.13	.88	1.19
	2, 5, 6, 7	4.000, 2.500, 3.000 & 3.5000	3.44			
	3	1.750	3.06			
	4	2.000	3.19			
8.00	1	1.380	2.81	3.25	.88	1.19
	2, 5, 6, 7, 8, 9 & 0	5.500, 2.500, 3.000, 3.500, 4.000, 4.500 & 5.000	3.44			
	3	1.750	3.06			
	4	2.000	3.19			



Stroke Data

Parker cylinders are available in any practical stroke length. The following information should prove helpful to you in selecting the proper stroke for your cylinder application.

Stroke Tolerances

Stroke length tolerances are required due to buildup of tolerances of piston, head, cap and cylinder tube. Standard production of stroke tolerances run $+ .031''$ to $- .015''$ up to 20" stroke, $+ .031''$ to $- .020''$ for 21" to 60" and $+ .031''$ to $- .031''$ for greater than 60" stroke. For closer tolerances on stroke length, it is necessary to specify the required tolerance plus the pressure and temperature at which the cylinder will operate. Stroke tolerances smaller than $.015''$ are not generally practical due to elasticity of cylinders. If machine design requires such close tolerances, use of a stroke adjuster may achieve the desired result.

Stop Tubing

Stop tube is recommended to lengthen the distance between the rod bearing and piston to reduce bearing loads when the cylinder is fully extended. This is especially true of horizontally mounted and long stroke cylinders. Long stroke cylinders achieve additional stability through the use of a stop tube.

Drawing A

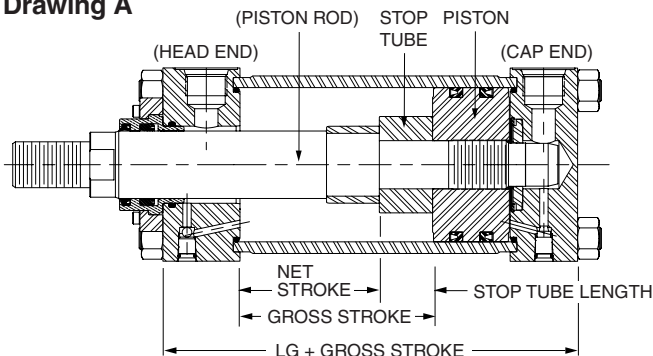

When specifying cylinders with long stroke and stop tube, be sure to call out the net stroke and the length of the stop tube. Machine design can be continued without delay by laying in a cylinder equivalent in length to the NET STROKE PLUS STOP TUBE LENGTH, which is referred to as GROSS STROKE.

Drawing B

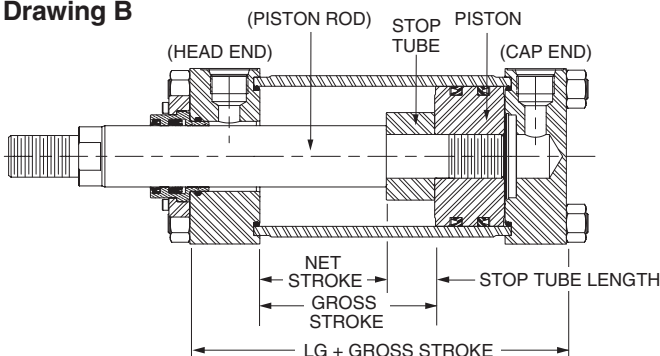

This design is supplied on all non-cushion cylinders.

Mounting Classes

Standard mountings for fluid power cylinders fall into three basic groups. The groups can be summarized as follows:

Group 1 Straight Line Force Transfer with fixed mounts which absorb force on cylinder centerline.

Group 2 Pivot Force Transfer. Pivot mountings permit a cylinder to change its alignment in one plane.

Group 3 Straight Line Force Transfer with fixed mounts which do not absorb force on cylinder centerline.

Because a cylinder's mounting directly affects the maximum pressure at which the cylinder can be used, the chart below should be helpful in selection of the proper mounting combination for your application. Stroke length, piston rod connection to load, extra piston rod length over standard, etc., should be considered for thrust loads. Alloy steel mounting bolts are recommended for all mounting styles, and thrust keys are recommended for Group 3.

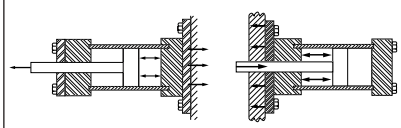
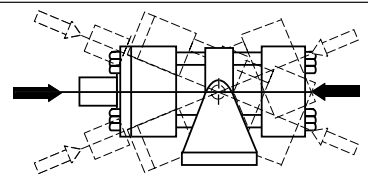
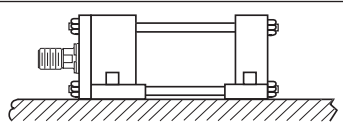
Group 1 FIXED MOUNTS which absorb force on cylinder centerline.	
<p>Heavy-Duty Service For Thrust Loads For Tension Loads</p>	 <p>Mtg. Styles HB, TC Mtg. Styles JB, JJ, TB</p>
<p>Medium-Duty Service For Thrust Loads For Tension Loads</p>	<p>Mtg. Styles H, JB Mtg. Styles J, HB</p>
<p>Light-Duty Service For Thrust Loads For Tension Loads</p>	<p>Mtg. Style F, J Mtg. Style H</p>
Group 2 PIVOT MOUNTS which absorb force on cylinder centerline.	
<p>Heavy-Duty Service For Thrust Loads For Tension Loads</p>	 <p>Mtg. Styles DD, D Mtg. Styles BB, DD, D, DB</p>
<p>Medium-Duty Service For Thrust Loads For Tension Loads</p>	<p>Style BB Style BB</p>
Group 3 FIXED MOUNTS which do not absorb force on the centerline.	
<p>Heavy-Duty Service For Thrust Loads For Tension Loads</p>	 <p>Mtg. Style C, CP Mtg. Style C, CP</p>
<p>Medium-Duty Service For Thrust Loads For Tension Loads</p>	<p>Mtg. Style F, FP Mts. Style F, FP</p>

How to Use the Chart

The selection of a piston rod for thrust (push) conditions requires the following steps:

1. Determine the type of cylinder mounting style and rod end connection to be used. Then consult the chart below and find the “stroke factor” that corresponds to the conditions used.

2. Using this stroke factor, determine the “basic length” from the equation:

$$\text{Basic Length} = \frac{\text{Actual Stroke}}{\text{Stroke Factor}}$$

The graph is prepared for standard rod extensions beyond the face of the rod gland retainers. For rod extensions greater than standard, add the increase to the stroke in arriving at the “basic length.”

3. Find the load imposed for the thrust application by multiplying the full bore area of the cylinder by the system pressure.
4. Enter the graph along the values of “basic length” and “thrust” as found above and note the point of intersection:
 - A) The correct piston rod size is read from the diagonally curved line labeled “Rod Diameter” next above the point of intersection.
 - B) The required length of stop tube is read from the right of the graph by following the shaded band in which the point of intersection lies.

- C) If required length of stop tube is in the region labeled “consult factory,” submit the following information for an individual analysis:
 - 1) Cylinder mounting style.
 - 2) Rod end connection and method of guiding load.
 - 3) Bore, required stroke, length of rod extension if greater than standard, and series of cylinder used.
 - 4) Mounting position of cylinder. (Note: If at an angle or vertical, specify direction of piston rod.)
 - 5) Operating pressure of cylinder if limited to less than standard pressure for cylinder selected.

Warning ⚠

Piston rods are not normally designed to absorb bending moments or loads which are perpendicular to the axis of piston rod motion. These additional loads can cause the piston rod end to fail. If these types of additional loads are expected to be imposed on the piston rods, their magnitude should be made known to our Engineering Department so they may be properly addressed. Additionally, cylinder users should always make sure that the piston rod is securely attached to the machine member.

Recommended Mounting Styles for Maximum Stroke and Thrust Loads	Rod End Connection	Case	Stroke Factor
Groups 1 or 3 Long stroke cylinders for thrust loads should be mounted using a heavy-duty mounting style at one end, firmly fixed and aligned to take the principal force. Additional mounting should be specified at the opposite end, which should be used for alignment and support. An intermediate support may also be desirable for long stroke cylinders mounted horizontally. See “Tie Rod Supports — Rigidity of Envelope” for a guide. Machine mounting pads can be adjustable for support mountings to achieve proper alignment.	Fixed and Rigidly Guided	I	.50
	Pivoted and Rigidly Guided	II	.70
	Supported but not Rigidly Guided	III	2.00
Group 2 Style D — Trunnion on Head	Pivoted and Rigidly Guided	IV	1.00
Style DD — Intermediate Trunnion	Pivoted and Rigidly Guided	V	1.50
Style DB — Trunnion on Cap or Style BB — Clevis on Cap	Pivoted and Rigidly Guided	VI	2.00



Piston Rod — Stroke Selection Chart — 1.00" through 8.00" Bore

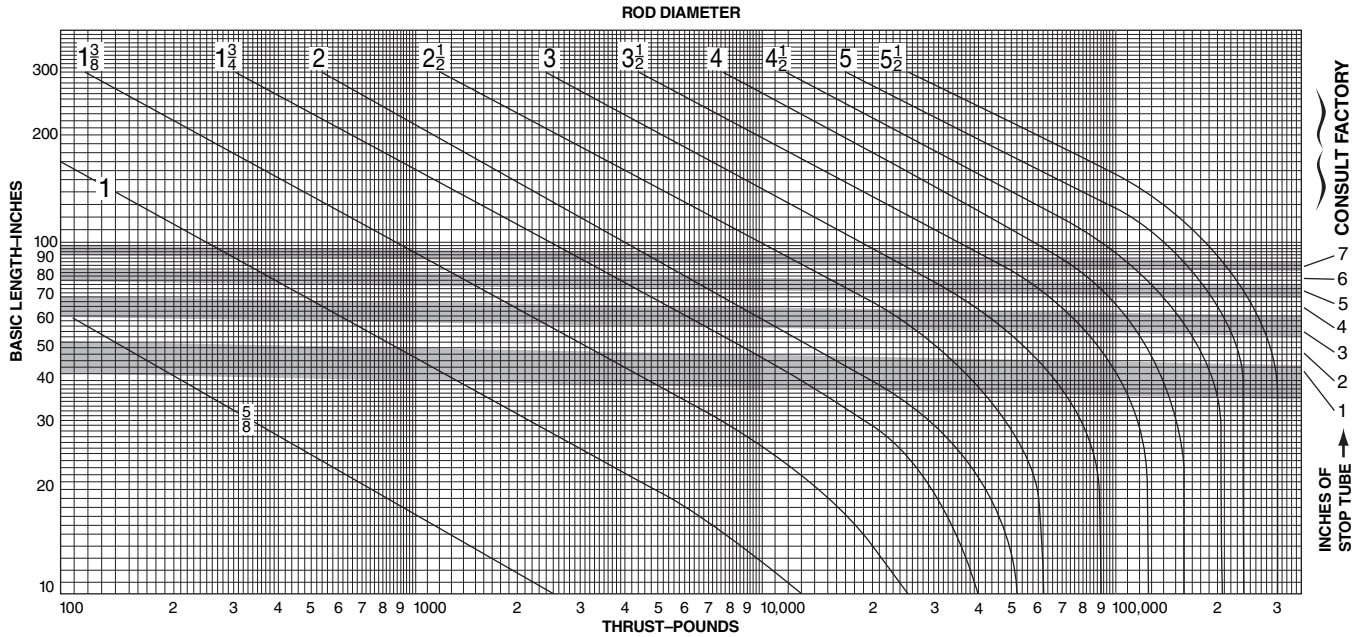

Application and Design Data

The spherical bearing life is influenced by many factors, i.e., bearing pressure, load direction oscillating angle and lubrication. The maximum operating pressure ratings of the spherical bearing mountings are based on standard commercial bearing ratings. The 4:1 design factor rating is based on the tensile strength of the material.

The spherical bearings are dimensioned to ensure a satisfactory bearing life under normal operating conditions. The bearing races are made of through-hardened steel and are precision ground. They are phosphate treated and coated with dry film lubricant to minimize friction of contacting surfaces. In the case of a permanent unidirectional load to the bearing, or other unusual operating conditions, the use of a larger bearing may be required.

For longer bearing life, regular lubrication will protect the spherical plain bearing from premature wear and corrosion. Rust-inhibiting EP greases of lithium base, preferably with molybdenum disulphide additives are particularly suited. The radial bearings have lubricating holes and grooves in the races permitting lubrication. The bearing housings at the cap and rod end are provided with grease fittings for lubrication.

Maximum angle of swivel in relation to the center line of the pivot pin is shown as angle **a** in the table below. It is recommended that this angle is not exceeded when mounting the cylinder.

Mounting Information

Head End Mounting

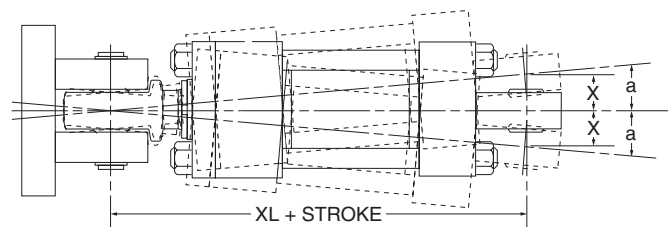

Recommended maximum swivel angle on each side of the cylinder centerline.

Table 1

Bore Ø	Head End Mounted		Cap End Mounted	
	Angle a	Tan. of a	Angle a	Tan. of a
1.50	2.50°	0.035	2.50°	0.035
2.00	2.50°	0.044	4.50°	0.079
2.50	2.50°	0.044	4.50°	0.079
3.25	3.50°	0.052	3.50°	0.052
4.00	2.50°	0.044	3.50°	0.052
5.00	3.50°	0.052	3.50°	0.052
6.00	3.50°	0.052	3.50°	0.052
8.00	3.50°	0.052	3.50°	0.052

Note: Dimension X is the maximum off center mounting of the cylinder. To determine dimension X for various stroke lengths multiply distance between pivot pin holes by tangent of angle a. For extended position use $X = XL + 2X \text{ stroke}$.

Cap End Mounting

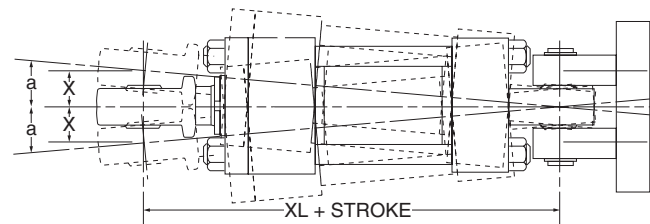

An Introduction to Cushioning

Cushioning is recommended as a means of controlling the deceleration of masses, or for applications where piston speed is in excess of 4 in/sec and the piston will make full stroke. Cushioning extends cylinder life and reduces undesirable noise and hydraulic shock. Built-in “cushions” are optional and can be supplied at the head and cap ends of a cylinder without affecting its envelope or mounting dimensions.

Standard Cushioning

Ideal cushion performance shows an almost uniform absorption of energy along the cushioning length, as shown. Many forms of cushioning exist, and each has its own specific merits and advantages.

In order to cover the majority of applications, 3L cylinders are supplied with profiled cushioning as standard. Final speed may be adjusted using the cushion screw. The performance of profiled cushioning is indicated on the diagram below.

Note: Cushion performance will be affected by the use of water or high water based fluids. Please consult factory for details.

Cushion Length

Where specified, 3L cylinders incorporate the longest cushion sleeve and spear that can be accommodated within the standard envelope without reducing the rod bearing and piston bearing length. See cushion lengths at right. Cushions are adjustable via recessed needle valves.

Cushion Performance

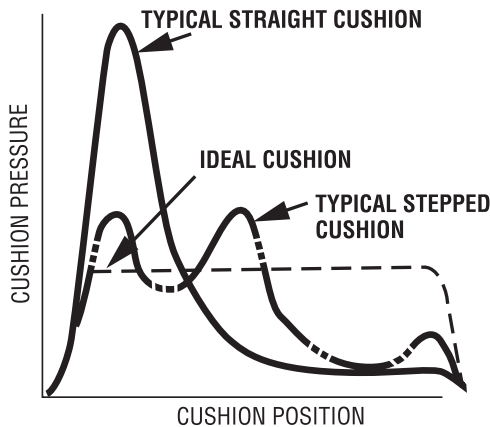

Cushion Length

Cylinder Bore (Inches)	Rod Ø ¹ (Inches)	Rod Number	Cushion Length (Inches)	
			Head ¹	Cap
1.00	0.500	1	0.88	0.75
	0.625	2	0.88	0.75
1.50	0.625	1	0.88	0.81
	1.000	2	0.88	0.81
2.00	0.625	1	0.88	0.81
	1.375	2	0.88	0.81
2.50	1.000	1	0.88	0.81
	1.750	2	0.88	0.81
3.25	1.000	1	1.13	1.00
	2.000	2	0.81	1.00
4.00	1.375	1	1.13	1.00
	2.500	2	0.81	1.00
5.00	1.750	1	1.13	1.00
	3.500	2	0.81	1.00
6.00	1.750	1	1.38	1.25
	4.000	2	1.06	1.25
8.00	2.000	1	1.06	1.25
	5.500	2	0.94	1.25

¹ Head end cushions for rod diameters not listed have cushion lengths within the limits shown.

Safety Guide for Selecting and Using Hydraulic, Pneumatic Cylinders and Their Accessories

WARNING: ⚠ FAILURE OF THE CYLINDER, ITS PARTS, ITS MOUNTING, ITS CONNECTIONS TO OTHER OBJECTS, OR ITS CONTROLS CAN RESULT IN:

- Unanticipated or uncontrolled movement of the cylinder or objects connected to it.
- Falling of the cylinder or objects held up by it.
- Fluid escaping from the cylinder, potentially at high velocity.

THESE EVENTS COULD CAUSE DEATH OR PERSONAL INJURY BY, FOR EXAMPLE, PERSONS FALLING FROM HIGH LOCATIONS, BEING CRUSHED OR STRUCK BY HEAVY OR FAST MOVING OBJECTS, BEING PUSHED INTO DANGEROUS EQUIPMENT OR SITUATIONS, OR SLIPPING ON ESCAPED FLUID.

Before selecting or using Parker Hannifin Corporation (the Company) cylinders or related accessories, it is important that you read, understand and follow the following safety information. Training is advised before selecting and using the Company's products.

1.0 General Instructions

1.1 Scope – This safety guide provides instructions for selecting and using (including assembling, installing, and maintaining) cylinder products. This safety guide is a supplement to and is to be used with the specific Company publications for the specific cylinder products that are being considered for use.

1.2 Fail Safe – Cylinder products can and do fail without warning for many reasons. All systems and equipment should be designed in a fail-safe mode so that if the failure of a cylinder product occurs people and property won't be endangered.

1.3 Distribution – Provide a free copy of this safety guide to each person responsible for selecting or using cylinder products. Do not select or use the Company's cylinders without thoroughly reading and understanding this safety guide as well as the specific Company publications for the products considered or selected.

1.4 User Responsibility – Due to very wide variety of cylinder applications and cylinder operating conditions, the Company does not warrant that any particular cylinder is suitable for any specific application. This safety guide does not analyze all technical parameters that must be considered in selecting a product. The hydraulic and pneumatic cylinders outlined in this catalog are designed to the Company's design guidelines and do not necessarily meet the design guideline of other agencies such as American Bureau of Shipping, ASME Pressure Vessel Code etc. The user, through its own analysis and testing, is solely responsible for:

- Making the final selection of the cylinders and related accessories.
- Determining if the cylinders are required to meet specific design requirements as required by the Agency(s) or industry standards covering the design of the user's equipment.
- Assuring that the user's requirements are met, OSHA requirements are met, and safety guidelines from the applicable agencies such as but not limited to ANSI are followed and that the use presents no health or safety hazards.
- Providing all appropriate health and safety warnings on the equipment on which the cylinders are used.

1.5 Additional Questions – Call the appropriate Company technical service department if you have any questions or require any additional information. See the Company publication for the product being considered or used, or call 1-847-298-2400, or go to www.parker.com, for telephone numbers of the appropriate technical service department.

2.0 Cylinder and Accessories Selection

2.1 Seals – Part of the process of selecting a cylinder is the selection of seal compounds. Before making this selection, consult the "seal information page(s)" of the publication for the series of cylinders of interest.

The application of cylinders may allow fluids such as cutting fluids, wash down fluids etc. to come in contact with the external area of the cylinder. These fluids may attack the piston rod wiper and or the primary seal and must be taken into account when selecting and specifying seal compounds.

Dynamic seals will wear. The rate of wear will depend on many operating factors. Wear can be rapid if a cylinder is mis-aligned or if the cylinder has been improperly serviced. The user must take seal wear into consideration in the application of cylinders.

2.2 Piston Rods – Possible consequences of piston rod failure or separation of the piston rod from the piston include, but are not limited to are:

- Piston rod and or attached load thrown off at high speed.
- High velocity fluid discharge.
- Piston rod extending when pressure is applied in the piston retract mode.

Piston rods or machine members attached to the piston rod may move suddenly and without warning as a consequence of other conditions occurring to the machine such as, but not limited to:

- Unexpected detachment of the machine member from the piston rod.

- Failure of the pressurized fluid delivery system (hoses, fittings, valves, pumps, compressors) which maintain cylinder position.
- Catastrophic cylinder seal failure leading to sudden loss of pressurized fluid.
- Failure of the machine control system.

Follow the recommendations of the "Piston Rod Selection Chart and Data" in the publication for the series of cylinders of interest. The suggested piston rod diameter in these charts must be followed in order to avoid piston rod buckling.

Piston rods are not normally designed to absorb bending moments or loads which are perpendicular to the axis of piston rod motion. These additional loads can cause the piston rod to fail. If these types of additional loads are expected to be imposed on the piston rod, their magnitude should be made known to our engineering department.

The cylinder user should always make sure that the piston rod is securely attached to the machine member.

On occasion cylinders are ordered with double rods (a piston rod extended from both ends of the cylinder). In some cases a stop is threaded on to one of the piston rods and used as an external stroke adjuster. On occasions spacers are attached to the machine member connected to the piston rod and also used as a stroke adjuster. In both cases the stops will create a pinch point and the user should consider appropriate use of guards. If these external stops are not perpendicular to the mating contact surface, or if debris is trapped between the contact surfaces, a bending moment will be placed on the piston rod, which can lead to piston rod failure. An external stop will also negate the effect of cushioning and will subject the piston rod to impact loading. Those two (2) conditions can cause piston rod failure. Internal stroke adjusters are available with and without cushions. The use of external stroke adjusters should be reviewed with our engineering department.

The piston rod to piston and the stud to piston rod threaded connections are secured with an anaerobic adhesive. The strength of the adhesive decreases with increasing temperature. Cylinders which can be exposed to temperatures above +250°F (+121°C) are to be ordered with a non studded piston rod and a pinned piston to rod joint.

2.3 Cushions – Cushions should be considered for cylinder applications when the piston velocity is expected to be over 4 inches/second.

Cylinder cushions are normally designed to absorb the energy of a linear applied load. A rotating mass has considerably more energy than the same mass moving in a linear mode. Cushioning for a rotating mass application should be reviewed by our engineering department.

2.4 Cylinder Mountings – Some cylinder mounting configurations may have certain limitations such as but not limited to minimum stroke for side or foot mounting cylinders or pressure de-ratings for certain mounts. Carefully review the catalog for these types of restrictions.

Always mount cylinders using the largest possible high tensile alloy steel socket head cap screws that can fit in the cylinder mounting holes and torque them to the manufacturer's recommendations for their size.

2.5 Port Fittings – Hydraulic cylinders applied with meter out or deceleration circuits are subject to intensified pressure at piston rod end.

The rod end pressure is approximately equal to:

$$\frac{\text{operating pressure} \times \text{effective cap end area}}{\text{effective rod end piston area}}$$

Contact your connector supplier for the pressure rating of individual connectors.

3.0 Cylinder and Accessories Installation and Mounting

3.1 Installation

3.1.1 – Cleanliness is an important consideration, and cylinders are shipped with the ports plugged to protect them from contaminants entering the ports. These plugs should not be removed until the piping is to be installed. Before making the connection to the cylinder ports, piping should be thoroughly cleaned to remove all chips or burrs which might have resulted from threading or flaring operations.

3.1.2 – Cylinders operating in an environment where air drying materials are present such as fast-drying chemicals, paint, or weld splatter, or other hazardous conditions such as excessive heat, should have shields installed to prevent damage to the piston rod and piston rod seals.

3.1.3 – Proper alignment of the cylinder piston rod and its mating component on the machine should be checked in both the extended and retracted positions. Improper alignment will result in excessive rod gland and/or cylinder bore wear. On fixed mounting cylinders attaching the piston rod while the rod is retracted will help in achieving proper alignment.

3.1.4 – Sometimes it may be necessary to rotate the piston rod in order to thread the piston rod into the machine member. This operation must always be done with zero pressure being applied to either side of the piston. Failure to follow this procedure may result in loosening the piston to rod-threaded connection. In some rare cases the turning of the piston rod may rotate a threaded piston rod gland and loosen it from the cylinder head. Confirm that this condition is not occurring. If it does, re-tighten the piston rod gland firmly against the cylinder head.

For double rod cylinders it is also important that when attaching or detaching the piston rod from the machine member that the torque be applied to the piston rod end of the cylinder that is directly attaching to the machine member with the opposite end unrestrained. If the design of the machine is such that only the rod end of the cylinder opposite to where the rod attaches to the machine member can be rotated, consult the factory for further instructions.

3.2 Mounting Recommendations

3.2.1 – Always mount cylinders using the largest possible high tensile alloy steel socket head screws that can fit in the cylinder mounting holes and torque them to the manufacturer's recommendations for their size.

3.2.2 – Side-Mounted Cylinders – In addition to the mounting bolts, cylinders of this type should be equipped with thrust keys or dowel pins located so as to resist the major load.

3.2.3 – Tie Rod Mounting – Cylinders with tie rod mountings are recommended for applications where mounting space is limited. The standard tie rod extension is shown as BB in dimension tables. Longer or shorter extensions can be supplied. Nuts used for this mounting style should be torqued to the same value as the tie rods for that bore size.

3.2.4 – Flange Mount Cylinders – The controlled diameter of the rod gland extension on head end flange mount cylinders can be used as a pilot to locate the cylinders in relation to the machine. After alignment has been obtained, the flanges may be drilled for pins or dowels to prevent shifting.

3.2.5 – Trunnion Mountings – Cylinders require lubricated bearing blocks with minimum bearing clearances. Bearing blocks should be carefully aligned and rigidly mounted so the trunnions will not be subjected to bending moments. The rod end should also be pivoted with the pivot pin in line and parallel to axis of the trunnion pins.

3.2.6 – Clevis Mountings – Cylinders should be pivoted at both ends with centerline of pins parallel to each other. After cylinder is mounted, be sure to check to assure that the cylinder is free to swing through its working arc without interference from other machine parts.

4.0 Cylinder and Accessories Maintenance, Troubleshooting and Replacement

4.1 Storage – At times cylinders are delivered before a customer is ready to install them and must be stored for a period of time. When storage is required the following procedures are recommended.

4.1.1 – Store the cylinders in an indoor area which has a dry, clean and noncorrosive atmosphere. Take care to protect the cylinder from both internal corrosion and external damage.

4.1.2 – Whenever possible cylinders should be stored in a vertical position (piston rod up). This will minimize corrosion due to possible condensation which could occur inside the cylinder. This will also minimize seal damage.

4.1.3 – Port protector plugs should be left in the cylinder until the time of installation.

4.1.4 – If a cylinder is stored full of hydraulic fluid, expansion of the fluid due to temperature changes must be considered. Installing a check valve with free flow out of the cylinder is one method.

4.1.5 – When cylinders are mounted on equipment that is stored outside for extended periods, exposed unpainted surfaces, e.g. piston rod, must be coated with a rust-inhibiting compound to prevent corrosion.

4.2 Cylinder Trouble Shooting

4.2.1 – External Leakage

4.2.1.1 – Rod seal leakage can generally be traced to worn or damaged seals. Examine the piston rod for dents, gouges or score marks, and replace piston rod if surface is rough.

Rod seal leakage could also be traced to gland wear. If clearance is excessive, replace rod bushing and seal. Rod seal leakage can also be traced to seal deterioration. If seals are soft or gummy or brittle, check compatibility of seal material with lubricant used if air cylinder, or operating fluid if hydraulic cylinder. Replace with seal material, which is compatible with these fluids. If the seals are hard or have lost elasticity, it is usually due to exposure to temperatures in excess of 165°F. (+74°C). Shield the cylinder from the heat source to limit temperature to 350°F. (+177°C.) and replace with fluorocarbon seals.

4.2.1.2 – Cylinder body seal leak can generally be traced to loose tie rods. Torque the tie rods to manufacturer's recommendation for that bore size.

Excessive pressure can also result in cylinder body seal leak. Determine maximum pressure to rated limits. Replace seals and retorqued tie rods as in paragraph above. Excessive pressure can also result in cylinder body seal leak. Determine if the pressure rating of the cylinder has been exceeded. If so, bring the operating pressure down to the rating of the cylinder and have the tie rods replaced.

Pinched or extruded cylinder body seal will also result in a leak. Replace cylinder body seal and retorqued as in paragraph above.

Cylinder body seal leakage due to loss of radial squeeze which shows up in the form of flat spots or due to wear on the O.D. or I.D. – Either of these are symptoms of normal wear due to high cycle rate or length of service. Replace seals as per paragraph above.

4.2.2 – Internal Leakage

4.2.2.1 – Piston seal leak (by-pass) 1 to 3 cubic inches per minute leakage is considered normal for piston ring construction. Virtually no static leak with lipseal type seals on piston should be expected. Piston seal wear is a usual cause of piston seal leakage. Replace seals as required.

4.2.2.2 – With lipseal type piston seals excessive back pressure due to over-adjustment of speed control valves could be a direct cause of rapid seal wear. Contamination in a hydraulic system can result in a scored cylinder bore, resulting in rapid seal wear. In either case, replace piston seals as required.

4.2.2.3 – What appears to be piston seal leak, evidenced by the fact that the cylinder drifts, is not always traceable to the piston. To make sure, it is suggested that one side of the cylinder piston be pressurized and the fluid line at the opposite port be disconnected. Observe leakage. If none is evident, seek the cause of cylinder drift in other component parts in the circuit.

4.2.3 – Cylinder Fails to Move the Load

4.2.3.1 – Pneumatic or hydraulic pressure is too low. Check the pressure at the cylinder to make sure it is to circuit requirements.

4.2.3.2 – Piston Seal Leak – Operate the valve to cycle the cylinder and observe fluid flow at valve exhaust ports at end of cylinder stroke. Replace piston seals if flow is excessive.

4.2.3.3 – Cylinder is undersized for the load – Replace cylinder with one of a larger bore size.

4.3 Erratic or Chatter Operation

4.3.1 – Excessive friction at rod gland or piston bearing due to load misalignment – Correct cylinder-to-load alignment.

4.3.2 – Cylinder sized too close to load requirements – Reduce load or install larger cylinder.

4.3.3 – Erratic operation could be traced to the difference between static and kinetic friction. Install speed control valves to provide a back pressure to control the stroke.

4.4 Cylinder Modifications, Repairs, or Failed Component

– Cylinders as shipped from the factory are not to be disassembled and or modified. If cylinders require modifications, these modifications must be done at company locations or by the Company's certified facilities. The Industrial Cylinder Division Engineering Department must be notified in the event of a mechanical fracture or permanent deformation of any cylinder component (excluding seals). This includes a broken piston rod, tie rod, mounting accessory or any other cylinder component. The notification should include all operation and application details. This information will be used to provide an engineered repair that will prevent recurrence of the failure.

It is allowed to disassemble cylinders for the purpose of replacing seals or seal assemblies. However, this work must be done by strictly following all the instructions provided with the seal kits.

Notes

Notes

Manufacturing Locations

Regional Plants

California

221 Helicopter Circle
Corona, CA 92880
Tel.: (951) 280-3800
Fax: (951) 280-3808
Fax: (800) 869-9886

Connecticut

80 Shaker Road
Enfield, CT 06082
Tel.: (860) 749-2215
Fax: (800) 323-0105

Georgia

1300 Six Flags Road
Lithia Springs, GA 30122
Tel.: (770) 819-3400
Fax: (800) 437-3498

Indiana

Goodland Plant
715 South Iroquois Street
Goodland, IN 47948
Tel.: (219) 297-3182
Fax: (800) 328-8120

Michigan

900 Plymouth Road
Plymouth, MI 48170
Tel.: (734) 455-1700
Fax: (734) 455-1007

Oregon

29289 Airport Road
Eugene, OR 97402-0079
Tel.: (541) 689-9111
Fax: (541) 688-6771
Fax: (800) 624-7996

Offer of Sale

The items described in this document and other documents and descriptions provided by Parker Hannifin Corporation, Hydraulics Group, and its authorized distributors ("Seller") are hereby offered for sale at prices to be established by Seller. This offer and its acceptance by any customer ("Buyer") shall be governed by all of the following Terms and Conditions. Buyer's order for any item described in its document, when communicated to Seller verbally, or in writing, shall constitute acceptance of this offer. All goods or work described will be referred to as "Products".

1. Terms and Conditions. Seller's willingness to offer Products, or accept an order for Products, to or from Buyer is expressly conditioned on Buyer's assent to these Terms and Conditions and to the terms and conditions found on-line at www.parker.com/saleterms/. Seller objects to any contrary or additional term or condition of Buyer's order or any other document issued by Buyer.

2. Price Adjustments; Payments. Prices stated on the reverse side or preceding pages of this document are valid for 30 days. After 30 days, Seller may change prices to reflect any increase in its costs resulting from state, federal or local legislation, price increases from its suppliers, or any change in the rate, charge, or classification of any carrier. The prices stated on the reverse or preceding pages of this document do not include any sales, use, or other taxes unless so stated specifically. Unless otherwise specified by Seller, all prices are F.O.B. Seller's facility, and payment is due 30 days from the date of invoice. After 30 days, Buyer shall pay interest on any unpaid invoices at the rate of 1.5% per month or the maximum allowable rate under applicable law.

3. Delivery Dates; Title and Risk; Shipment. All delivery dates are approximate and Seller shall not be responsible for any damages resulting from any delay. Regardless of the manner of shipment, title to any products and risk of loss or damage shall pass to Buyer upon tender to the carrier at Seller's facility (i.e., when it's on the truck, it's yours). Unless otherwise stated, Seller may exercise its judgment in choosing the carrier and means of delivery. No deferment of shipment at Buyers' request beyond the respective dates indicated will be made except on terms that will indemnify, defend and hold Seller harmless against all loss and additional expense. Buyer shall be responsible for any additional shipping charges incurred by Seller due to Buyer's changes in shipping, product specifications or in accordance with Section 13, herein.

4. Warranty. Seller warrants that the Products sold hereunder shall be free from defects in material or workmanship for a period of eighteen months from the date of delivery to Buyer. The prices charged for Seller's products are based upon the exclusive limited warranty stated above, and upon the following disclaimer: **DISCLAIMER OF WARRANTY: THIS WARRANTY COMPRISES THE SOLE AND ENTIRE WARRANTY PERTAINING TO PRODUCTS PROVIDED HEREUNDER. SELLER DISCLAIMS ALL OTHER WARRANTIES, EXPRESS AND IMPLIED, INCLUDING MERCHANTABILITY AND FITNESS FOR A PARTICULAR PURPOSE.**

5. Claims; Commencement of Actions. Buyer shall promptly inspect all Products upon delivery. No claims for shortages will be allowed unless reported to the Seller within 10 days of delivery. No other claims against Seller will be allowed unless asserted in writing within 60 days after delivery or, in the case of an alleged breach of warranty, within 30 days after the date within the warranty period on which the defect is or should have been discovered by Buyer. Any action based upon breach of this agreement or upon any other claim arising out of this sale (other than an action by Seller for any amount due to Seller from Buyer) must be commenced within thirteen months from the date of tender of delivery by Seller or, for a cause of action based upon an alleged breach of warranty, within thirteen months from the date within the warranty period on which the defect is or should have been discovered by Buyer.

6. LIMITATION OF LIABILITY. UPON NOTIFICATION, SELLER WILL, AT ITS OPTION, REPAIR OR REPLACE A DEFECTIVE PRODUCT, OR REFUND THE PURCHASE PRICE. IN NO EVENT SHALL SELLER BE LIABLE TO BUYER FOR ANY SPECIAL, INDIRECT, INCIDENTAL OR CONSEQUENTIAL DAMAGES ARISING OUT OF, OR AS THE RESULT OF, THE SALE, DELIVERY, NON-DELIVERY, SERVICING, USE OR LOSS OF USE OF THE PRODUCTS OR ANY PART THEREOF, OR FOR ANY CHARGES OR EXPENSES OF ANY NATURE INCURRED WITHOUT SELLER'S WRITTEN CONSENT, EVEN IF SELLER HAS BEEN NEGLIGENT, WHETHER IN CONTRACT, TORT OR OTHER LEGAL THEORY. IN NO EVENT SHALL SELLER'S LIABILITY UNDER ANY CLAIM MADE BY BUYER EXCEED THE PURCHASE PRICE OF THE PRODUCTS.

7. Contingencies. Seller shall not be liable for any default or delay in performance if caused by circumstances beyond the reasonable control of Seller.

8. User Responsibility. The user, through its own analysis and testing, is solely responsible for making the final selection of the system and Product and assuring that all performance, endurance, maintenance, safety and warning requirements of the application are met. The user must analyze all aspects of the application and follow applicable industry standards and Product information. If Seller provides Product or system options, the user is responsible for determining that such data and specifications are suitable and sufficient for all applications and reasonably foreseeable uses of the Products or systems.

9. Loss to Buyer's Property. Any designs, tools, patterns, materials, drawings, confidential information or equipment furnished by Buyer or any other items which become Buyer's property, may be considered obsolete and may be destroyed by Seller after two consecutive years have elapsed without Buyer placing an order for the items which are manufactured using such property. Seller shall not be responsible for any loss or damage to such property while it is in Seller's possession or control.

10. Special Tooling. A tooling charge may be imposed for any special tooling, including without limitation, dies, fixtures, molds and patterns, acquired to manufacture Products. Such special tooling shall be and remain Seller's property notwithstanding payment of any charges by Buyer. In no event will Buyer acquire any interest in apparatus belonging to Seller which is utilized in the manufacture of the Products, even if such apparatus has been specially converted or adapted for such manufacture and notwithstanding any charges paid by Buyer. Unless otherwise agreed, Seller shall have the right to alter, discard or otherwise dispose of any special tooling or other property in its sole discretion at any time.

11. Buyer's Obligation; Rights of Seller. To secure payment of all sums due or otherwise, Seller shall retain a security interest in the goods delivered and this agreement shall be deemed a Security Agreement under the Uniform Commercial Code. Buyer authorizes Seller as its attorney to execute and file on Buyer's behalf all documents Seller deems necessary to perfect its security interest. Seller shall have a security interest in, and lien upon, any property of Buyer in Seller's possession as security for the payment of any amounts owed to Seller by Buyer.

12. Improper Use and Indemnity. Buyer shall indemnify, defend, and hold Seller harmless from any claim, liability, damages, lawsuits, and costs (including attorney fees), whether for personal injury, property damage, patent, trademark or copyright infringement or any other claim, brought by or incurred by Buyer, Buyer's employees, or any other person, arising out of: (a) improper selection, improper application or other misuse of Products purchased by Buyer from Seller; (b) any act or omission, negligent or otherwise, of Buyer; (c) Seller's use of patterns, plans, drawings, or specifications furnished by Buyer to manufacture Product; or (d) Buyer's failure to comply with these terms and conditions. Seller shall not indemnify Buyer under any circumstance except as otherwise provided.

13. Cancellations and Changes. Orders shall not be subject to cancellation or change by Buyer for any reason, except with Seller's written consent and upon terms that will indemnify, defend and hold Seller harmless against all direct, incidental and consequential loss or damage. Seller may change product features, specifications, designs and availability with notice to Buyer.

14. Limitation on Assignment. Buyer may not assign its rights or obligations under this agreement without the prior written consent of Seller.

15. Entire Agreement. This agreement contains the entire agreement between the Buyer and Seller and constitutes the final, complete and exclusive expression of the terms of the agreement. All prior or contemporaneous written or oral agreements or negotiations with respect to the subject matter are herein merged.

16. Waiver and Severability. Failure to enforce any provision of this agreement will not waive that provision nor will any such failure prejudice Seller's right to enforce that provision in the future. Invalidation of any provision of this agreement by legislation or other rule of law shall not invalidate any other provision herein. The remaining provisions of this agreement will remain in full force and effect.

17. Termination. This agreement may be terminated by Seller for any reason and at any time by giving Buyer thirty (30) days written notice of termination. In addition, Seller may by written notice immediately terminate this agreement for the following: (a) Buyer commits a breach of any provision of this agreement (b) the appointment of a trustee, receiver or custodian for all or any part of Buyer's property (c) the filing of a petition for relief in bankruptcy of the other Party on its own behalf, or by a third party (d) an assignment for the benefit of creditors, or (e) the dissolution or liquidation of the Buyer.

18. Governing Law. This agreement and the sale and delivery of all Products hereunder shall be deemed to have taken place in and shall be governed and construed in accordance with the laws of the State of Ohio, as applicable to contracts executed and wholly performed therein and without regard to conflicts of laws principles. Buyer irrevocably agrees and consents to the exclusive jurisdiction and venue of the courts of Cuyahoga County, Ohio with respect to any dispute, controversy or claim arising out of or relating to this agreement. Disputes between the parties shall not be settled by arbitration unless, after a dispute has arisen, both parties expressly agree in writing to arbitrate the dispute.

19. Indemnity for Infringement of Intellectual Property Rights. Seller shall have no liability for infringement of any patents, trademarks, copyrights, trade dress, trade secrets or similar rights except as provided in this Section. Seller will defend and indemnify Buyer against allegations of infringement of U.S. patents, U.S. trademarks, copyrights, trade dress and trade secrets ("Intellectual Property Rights"). Seller will defend at its expense and will pay the cost of any settlement or damages awarded in an action brought against Buyer based on an allegation that a Product sold pursuant to this Agreement infringes the Intellectual Property Rights of a third party. Seller's obligation to defend and indemnify Buyer is contingent on Buyer notifying Seller within ten (10) days after Buyer becomes aware of such allegations of infringement, and Seller having sole control over the defense of any allegations or actions including all negotiations for settlement or compromise. If a Product is subject to a claim that it infringes the Intellectual Property Rights of a third party, Seller may, at its sole expense and option, procure for Buyer the right to continue using the Product, replace or modify the Product so as to make it noninfringing, or offer to accept return of the Product and return the purchase price less a reasonable allowance for depreciation. Notwithstanding the foregoing, Seller shall have no liability for claims of infringement based on information provided by Buyer, or directed to Products delivered hereunder for which the designs are specified in whole or part by Buyer, or infringements resulting from the modification, combination or use in a system of any Product sold hereunder. The foregoing provisions of this Section shall constitute Seller's sole and exclusive liability and Buyer's sole and exclusive remedy for infringement of Intellectual Property Rights.

20. Taxes. Unless otherwise indicated, all prices and charges are exclusive of excise, sales, use, property, occupational or like taxes which may be imposed by any taxing authority upon the manufacture, sale or delivery of Products.

21. Equal Opportunity Clause. For the performance of government contracts and where dollar value of the Products exceed \$10,000, the equal employment opportunity clauses in Executive Order 11246, VEVRAA, and 41 C.F.R. §§ 60-1.4(a), 60-741.5(a), and 60-250.4, are hereby incorporated.

Parker's Motion & Control Technologies

At Parker, we're guided by a relentless drive to help our customers become more productive and achieve higher levels of profitability by engineering the best systems for their requirements. It means looking at customer applications from many angles to find new ways to create value. Whatever the motion and control technology need, Parker has the experience, breadth of product and global reach to consistently deliver. No company knows more about motion and control technology than Parker. For further info call 1 800 C-Parker (1 800 272 7537).



AEROSPACE

Key Markets

- Aircraft engines
- Business & general aviation
- Commercial transports
- Land-based weapons systems
- Military aircraft
- Missiles & launch vehicles
- Regional transports
- Unmanned aerial vehicles

Key Products

- Flight control systems & components
- Fluid conveyance systems
- Fluid metering delivery & atomization devices
- Fuel systems & components
- Hydraulic systems & components
- Inert nitrogen generating systems
- Pneumatic systems & components
- Wheels & brakes



CLIMATE CONTROL

Key Markets

- Agriculture
- Air conditioning
- Food, beverage & dairy
- Life sciences & medical
- Precision cooling
- Processing
- Transportation

Key Products

- CO₂ controls
- Electronic controllers
- Filter driers
- Hand shut-off valves
- Hose & fittings
- Pressure regulating valves
- Refrigerant distributors
- Safety relief valves
- Solenoid valves
- Thermostatic expansion valves



ELECTROMECHANICAL

Key Markets

- Aerospace
- Factory automation
- Food & beverage
- Life science & medical
- Machine tools
- Packaging machinery
- Paper machinery
- Plastics machinery & converting
- Primary metals
- Semiconductor & electronics
- Textile
- Wire & cable

Key Products

- AC/DC drives & systems
- Electric actuators
- Controllers
- Gantry robots
- Gearheads
- Human machine interfaces
- Industrial PCs
- Inverters
- Linear motors, slides and stages
- Precision stages
- Stepper motors
- Servo motors, drives & controls
- Structural extrusions



FILTRATION

Key Markets

- Food & beverage
- Industrial machinery
- Life sciences
- Marine
- Mobile equipment
- Oil & gas
- Power generation
- Process
- Transportation

Key Products

- Analytical gas generators
- Compressed air & gas filters
- Condition monitoring
- Engine air, fuel & oil filtration & systems
- Hydraulic, lubrication & coolant filters
- Process, chemical, water & microfiltration filters
- Nitrogen, hydrogen & zero air generators



FLUID & GAS HANDLING

Key Markets

- Aerospace
- Agriculture
- Bulk chemical handling
- Construction machinery
- Food & beverage
- Fuel & gas delivery
- Industrial machinery
- Mobile
- Oil & gas
- Transportation
- Welding

Key Products

- Brass fittings & valves
- Diagnostic equipment
- Fluid conveyance systems
- Industrial hose
- PTFE & PFA hose, tubing & plastic fittings
- Rubber & thermoplastic hose & couplings
- Tube fittings & adapters
- Quick disconnects



HYDRAULICS

Key Markets

- Aerospace
- Aerial lift
- Agriculture
- Construction machinery
- Forestry
- Industrial machinery
- Mining
- Oil & gas
- Power generation & energy
- Truck hydraulics

Key Products

- Diagnostic equipment
- Hydraulic cylinders & accumulators
- Hydraulic motors & pumps
- Hydraulic systems
- Hydraulic valves & controls
- Power take-offs
- Rubber & thermoplastic hose & couplings
- Tube fittings & adapters
- Quick disconnects



PNEUMATICS

Key Markets

- Aerospace
- Conveyor & material handling
- Factory automation
- Food & beverage
- Life science & medical
- Machine tools
- Packaging machinery
- Transportation & automotive

Key Products

- Air preparation
- Compact cylinders
- Field bus valve systems
- Grippers
- Guided cylinders
- Manifolds
- Miniature fluidics
- Pneumatic accessories
- Pneumatic actuators & grippers
- Pneumatic valves and controls
- Rodless cylinders
- Rotary actuators
- Tie rod cylinders
- Vacuum generators, cups & sensors



PROCESS CONTROL

Key Markets

- Chemical & refining
- Food, beverage & dairy
- Medical & dental
- Microelectronics
- Oil & gas
- Power generation

Key Products

- Analytical sample conditioning products & systems
- Fluoropolymer chemical delivery fittings, valves & pumps
- High purity gas delivery fittings, valves & regulators
- Instrumentation fittings, valves & regulators
- Medium pressure fittings & valves
- Process control manifolds

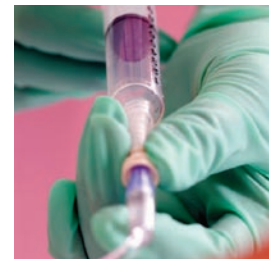

SEALING & SHIELDING

Key Markets

- Aerospace
- Chemical processing
- Consumer
- Energy, oil & gas
- Fluid power
- General industrial
- Information technology
- Life sciences
- Military
- Semiconductor
- Telecommunications
- Transportation

Key Products

- Dynamic seals
- Elastomeric o-rings
- EMI shielding
- Extruded & precision-cut, fabricated elastomeric seals
- Homogeneous & inserted elastomeric shapes
- High temperature metal seals
- Metal & plastic retained composite seals
- Thermal management



ENGINEERING YOUR SUCCESS.



← **Smart phone scan here**

Scan this QR code with your smart phone to download the catalog. Look for QR code readers at an "App Store" for your smart phone.

3/11 / Catalog HY08-1130-3/NA



Parker Hannifin Corporation
Industrial Cylinder Division
500 South Wolf Road
Des Plaines, IL 60016 USA
phone (847) 298-2400
fax (800) 892-1008
www.parker.com/cylinder

Parker Hannifin Corporation
Motion and Control Division
160 Chisholm Drive
Milton, ON Canada L9T 3G9
direct (905) 693-3000
fax (905) 876-1958
www.parker.com

Metric Hydraulic Cylinders Series HMI

Conforms to ISO 6020/2 (1991)
For working pressures up to 210 bar

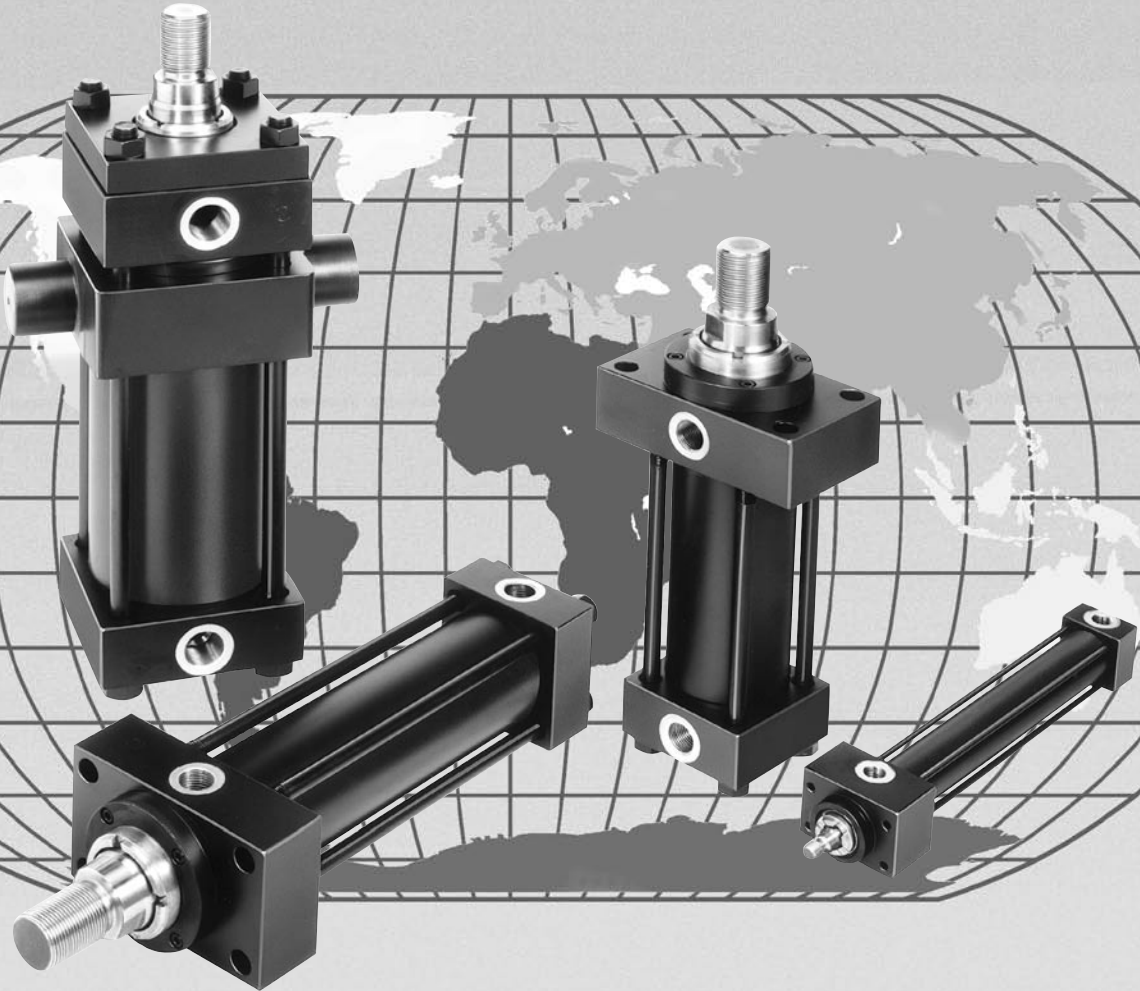

*Vital Technologies for
Motion and Control*

For Cylinder Division Plant Locations – See Page II.

Parker Series HMI Metric Hydraulic Cylinders

As the world leader in the design and manufacture of tie-rod cylinders, Parker Cylinder Division introduces the Parker Series HMI *metric* hydraulic cylinder. Parker's HMI Series cylinders are designed to meet the requirements of ISO 6020/2 (1991), 160 Bar Compact Series. HMI Series cylinders may be used for working pressures up to 210 Bar.



Parker HMI Series cylinders are the true *world standard*, available all over the globe from Parker's worldwide manufacturing facilities. Whether you or your machine are in Europe, Asia, South America, Canada, Mexico, or the United States, you can rely on the engineering expertise, manufacturing experience, and commitment to quality that you've come to expect from the Parker Cylinder Division.

For additional information – call your local Parker Cylinder Distributor.

Parker Series HMI Metric Hydraulic Cylinders

Features, Specifications
and Mountings

Series HMI Standard Features and Specifications

- ISO 6020/2 mounting interchangeable
- 12 standard mounting styles
- Up to 3 rod sizes per bore
- Wide range of mounting accessories
- Up to 3 male and 3 female rod end threads per bore
- Bore sizes – 25mm to 200mm
- Strokes – available in any practical stroke length
- Working pressure up to 210 bar
- Piston rods – 12mm to 140mm
- Single and Double rod designs
- Cushions available at either end
- Temperature Range – -20°C to 150°C depending on seal type
- Seal types to suit a wide variety of operating environments

In line with our policy of continuing product improvement, specifications in this catalog are subject to change.

Available Mountings and Where To Find Them

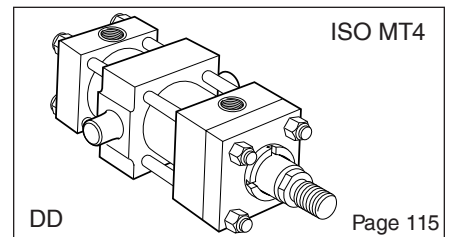
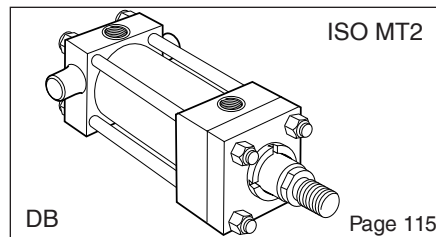
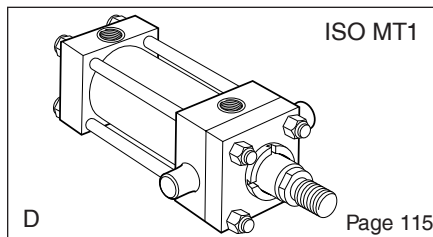
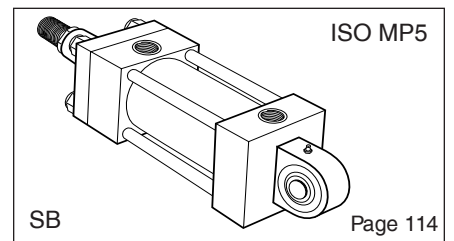
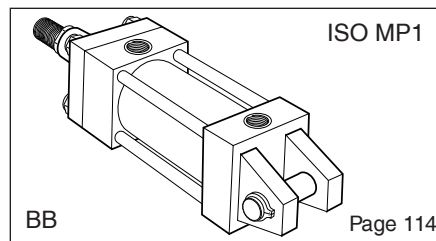
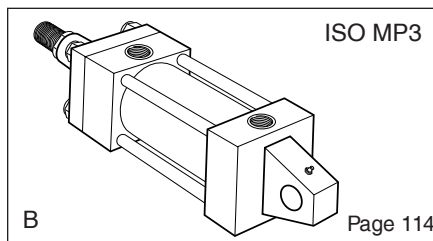
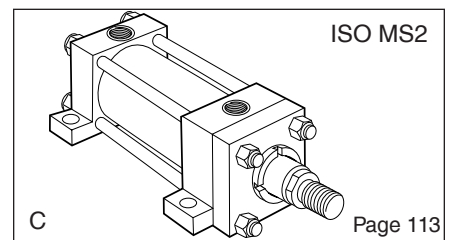
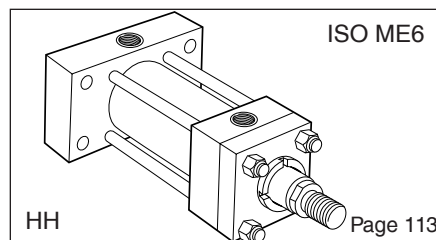
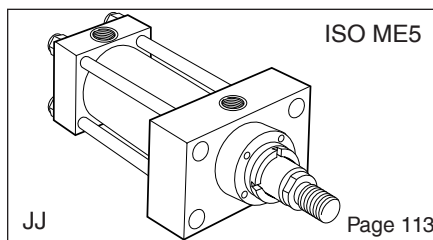
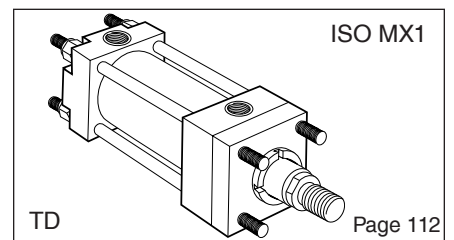
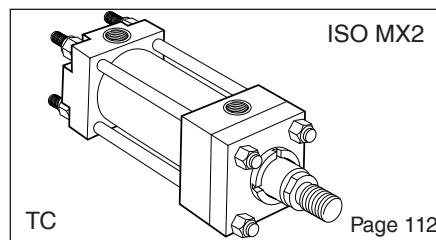
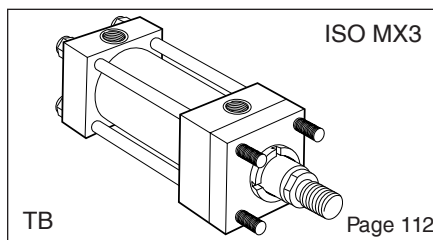

For Cylinder Division Plant Locations – See Page II.

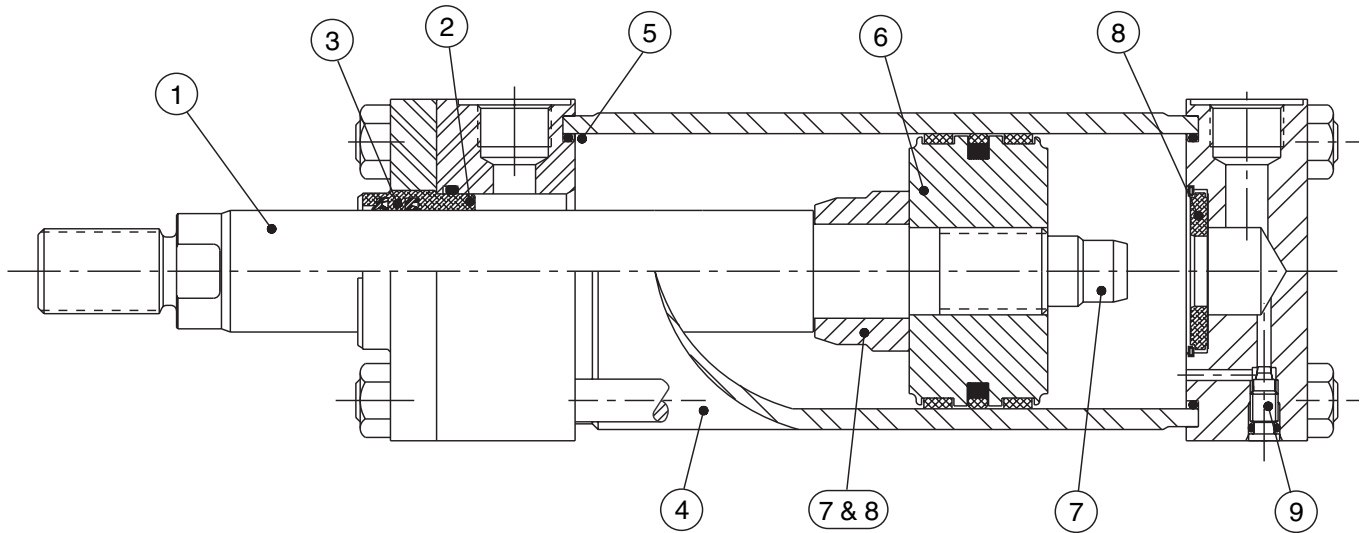

1 Piston Rod

Gland seal life is maximized by manufacturing piston rods from precision ground, high tensile carbon alloy steel, hard chrome plated and polished to 0.2µm max.

2 Parker's 'Jewel' Gland

Continuous lubrication, and therefore longer gland life, are provided by the long bearing surface inboard of the primary seal. The Jewel gland, complete with rod seals, can easily

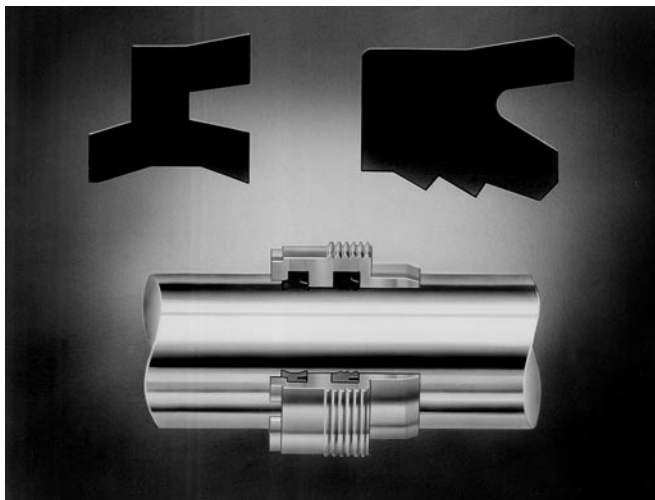

be removed without dismantling the cylinder, so servicing is quicker – and therefore more economical.

3 Rod Seals

The TS-2000 primary seal has a series of sealing edges which take over successively as pressure increases, providing efficient sealing under all operating conditions. On the return stroke the serrations act as a check valve, allowing the oil adhering to the rod to pass back into the cylinder.

The double lip wiperseal acts as a secondary seal, trapping excess lubricating film in the chamber between the wiper and

lip seals. Its outer lip prevents the ingress of dirt into the cylinder, extending the life of gland and seals.

The TS-2000 is manufactured from an enhanced polyurethane, giving efficient retention of pressurized fluid and long service life.

4 Cylinder Body

Strict quality control standards and precision manufacture ensure that all tubes meet rigid standards of straightness, roundness and surface finish. The steel tubing is surface finished to minimize internal friction and prolong seal life.

5 Cylinder Body Seals

To make sure that the cylinder body remains leaktight, even under pressure shock conditions, Parker utilizes pressure-energized body seals.

6 One-Piece Piston

Side loading is resisted by the wide bearing surfaces of the pistons. A long thread engagement secures the piston to the piston rod and, as an added safety feature, pistons are secured by an anaerobic adhesive.

7 Cushioning

Progressive deceleration is available by using profiled cushions at the head and cap – see Section C for details. The head end cushion is self aligning, while the polished cap end spear is an integral part of the piston rod.

8 Floating Cushion Bushings and Sleeves

Closer tolerances – and therefore more effective cushioning – are permitted by the use of a floating cushion sleeve at the head end of the cylinder, and a floating cushion bushing at the cap end. A slotted cushion sleeve at the head end and the floating bronze cushion bushing in the cap, provide minimum fluid restriction at the start of the return stroke. This allows full pressure to be applied over the entire area of the piston, providing full power and fast cycle times.

For additional information – call your local Parker Cylinder Distributor.

Parker Series HMI Metric Hydraulic Cylinders

Design Features and Benefits

9 Cushion Adjustment

Needle valves are provided at both ends of the cylinder for precise cushion adjustment. 63 mm bores and smaller contain cartridge cushion assembly shown below.

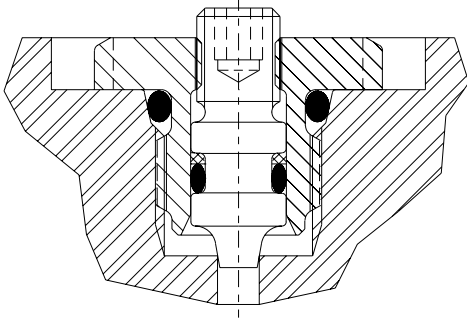

Air Bleeds

Available as an option at both ends, the air bleeds are recessed into the head and cap.

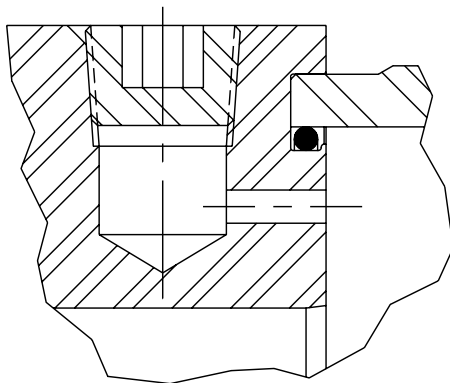

Gland Drains

The accumulation of fluid behind the gland wiperseal of long stroke cylinders, or cylinders with constant back pressure, can be relieved by specifying the option of a gland drain. A port between the wiperseal and primary seal allows fluid to be piped back to a reservoir. By fitting a transparent tube between the port and the reservoir, fluid loss from concealed or inaccessible cylinders can be monitored to provide an early indication of the need for gland servicing. Gland drains are described in greater detail in Section C of this catalog.

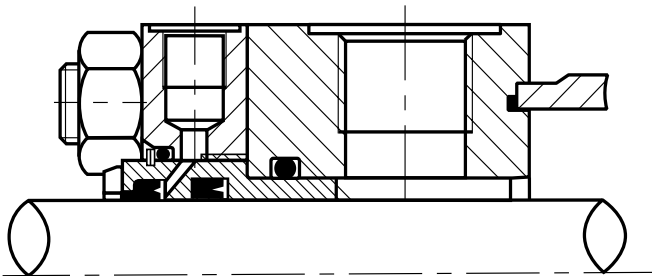

Piston Seals

Standard on 25mm, 32mm and 40mm bore sizes, Parker's Lipseal® Piston provides zero leakage under static conditions for hydraulic pressures up to 3000 psi. Seals are self-compensating to conform to variations in pressure, mechanical deflection, and wear. Back-up washers prevent extrusion.

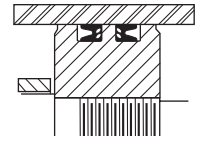

Standard on 50mm bore sizes and larger, Parker's B style piston is a single seal design which incorporates two wear strips. This design provides smooth operation, long bearing life, and high load carrying capacity.

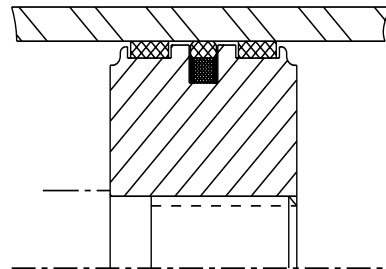

Mixed Media Piston Seals

For applications requiring different media on either side of the piston specify Mixed Media Piston Seals with a W piston code. This option is ideal when hydraulic oil is on one side of the piston and air on the opposite side; and it can be equally effective when dissimilar fluids are on either side of the piston. Superior low-friction bi-directional sealing is accomplished by combining an energized filled PTFE seal with a redundant elastomer seal.

Servo Cylinders

Servo cylinders permit fine control of acceleration, velocity and position in applications where very low friction and an absence of stick-slip are required. They may be used in conjunction with integral or external transducers. Servo cylinders combine low friction piston and gland seals with specially selected tubes and rods. For low-friction applications – consult factory.

Seal Classes

To accommodate the many types of fluids and the varying temperature ranges used in industry, Parker offers a range of rod gland, piston and body seals. These are described in detail in Section C of this catalog.

B

For Cylinder Division Plant Locations – See Page II.



Parker Series HMI Metric Hydraulic Cylinders

Mounting Styles

ISO Cylinder Mounting Styles and Where to Find Them

The standard range of Parker Series HMI cylinders comprises 12 ISO mounting styles, to suit the majority of applications. General guidance for the selection of ISO cylinders is given below, with dimensional information about each mounting style shown on the following pages. Application-specific mounting information is shown in the mounting information section, Section C of this catalog.

Extended Tie Rods

Cylinders with TB, TC and TD mountings are suitable for straight line force transfer applications, and are particularly useful where space is limited. For compression (push) applications, cap end tie rod mountings are most appropriate; where the major load places the piston rod in tension (pull applications), head end mounting styles should be specified. Cylinders with tie rods extended at both ends may be attached to the machine member from either end, allowing the free end of the cylinder to support a bracket or switch.

Flange Mounted Cylinders

These cylinders are also suitable for use on straight line force transfer applications. Two flange mounting styles are available, offering either a head flange (JJ) or a cap flange (HH). Selection of the correct flange mounting style depends on whether the major force applied to the load will result in compression (push) or tension (pull) stresses on the piston rod. For compression-type applications, the cap mounting style is most appropriate; where the major load places the piston rod in tension, a head mounting should be specified.

Foot Mounted Cylinders

Style C, foot mounted cylinders do not absorb forces on their centerline. As a result, the application of force by the cylinder produces a moment which attempts to rotate the cylinder about its mounting bolts. It is important, therefore, that the cylinder should be firmly secured to the mounting surface and that the load should be effectively guided to avoid side loads being applied to rod gland and piston bearings. A thrust key modification may be specified to provide positive cylinder location.

Pivot Mountings

Cylinders with pivot mountings, which absorb forces on their centerlines, should be used where the machine member to be moved travels in a curved path. Pivot mountings may be used for tension (pull) or compression (push) applications. Cylinders using a fixed clevis, styles BB and B, may be used if the curved path of the piston rod travel is in a single plane; for applications where the piston rod will travel in a path on either side of the true plane of motion, a spherical bearing mounting SB is recommended.

Trunnion Mounted Cylinders

These cylinders, styles D, DB and DD, are designed to absorb force on their centerlines. They are suitable for tension (pull) or compression (push) applications, and may be used where the machine member to be moved travels in a curved path in a single plane. Trunnion pins are designed for shear loads only and should be subjected to minimum bending stresses.

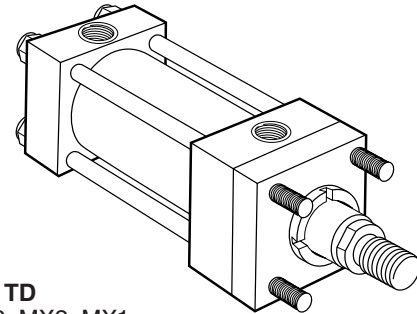

Styles TB, TC, TD
ISO Styles MX3, MX2, MX1

TB

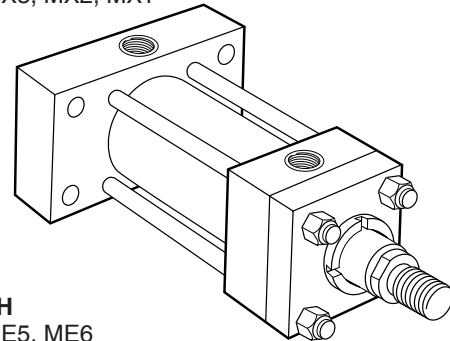

Styles JJ, HH
ISO Styles ME5, ME6

HH

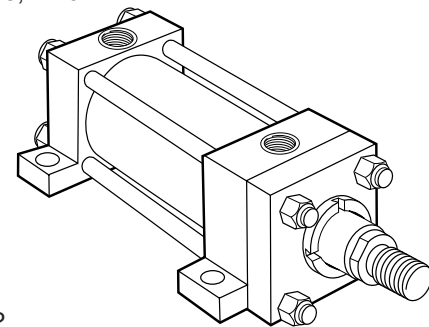

Style C
ISO Style MS2

C

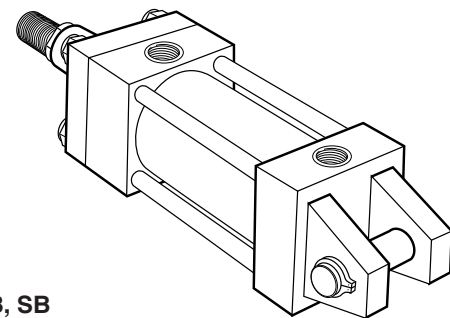

Styles B, BB, SB
ISO Styles MP3, MP1, MP5

BB

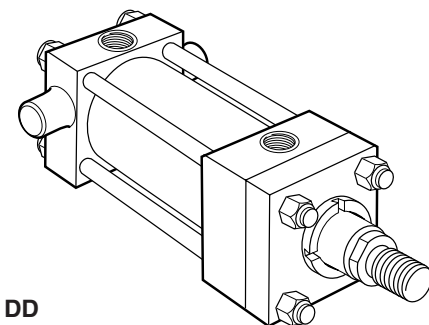

Styles D, DB, DD
ISO Styles MT1, MT2, MT4

DB

For additional information – call your local Parker Cylinder Distributor.

Parker Series HMI Metric Hydraulic Cylinders

Piston Rod End Data and Threads

Parker Thread Styles 4 & 7 – All Except JJ Mount

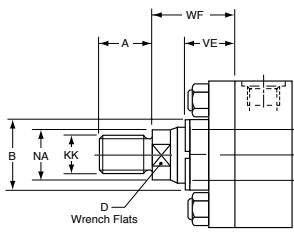

Parker Thread Styles 4 & 7 – JJ Mount

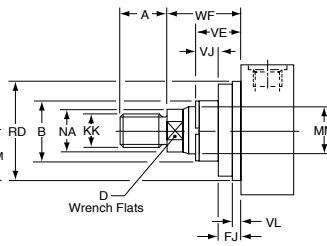

Parker Thread Styles 4 & 7

The smallest diameter rod end thread for each bore size is designated Style 4 when supplied with a No.1 rod. When the same rod end thread is supplied with a No. 2 or No. 3 rod, it is designated Style 7.

Parker Thread Style 9 – Short Stroke Cylinders

Style 9 (female) rod ends should not be used on 160mm or 200mm bore cylinders with a stroke of 50mm or less. Please consult the factory, with details of the application.

Parker Thread Style 3

Non-standard piston rod ends are designated 'Style 3'. A dimensional sketch or description should accompany the order. Please specify dimensions KK or KF, A, rod stand out WF and thread type.

25 & 32mm Bore Cylinders

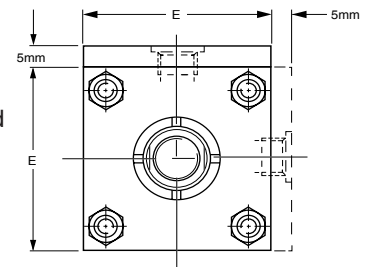

5mm extra height applies to port face at head end only.

Gland Retainer – 160 and 200mm Bore

On all 160mm and 200mm bore ISO mounting styles except TB and TD, the gland retainer is separately bolted to the head, as shown.

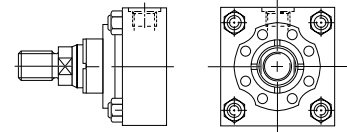

Parker Thread Style 9 – All Except JJ Mount

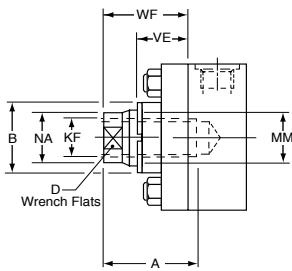

Parker Thread Style 9 – JJ Mount

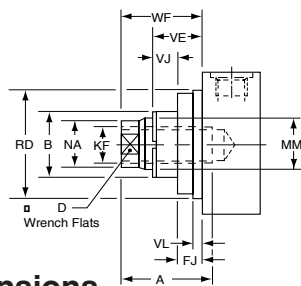

Piston Rod End Dimensions

Bore φ	Rod No.	MM Rod φ	Style 4		Style 7		Style 9		B f9	D	NA	VE	WF	JJ Mount Only			
			KK	A	KK	A	KF	A						VL min	RD f8	VJ	FJ
25	1	12	M10x1.25	14	-	-	M8x1	14	24	10	11	16	25	3	38	6	10
	2	18	M14x1.5	18	M10x1.25	14	M12x1.25	18	30	15	17	16					
32	1	14	M12x1.25	16	-	-	M10x1.25	16	26	12	13	22	35	3	42	12	10
	2	22	M16x1.5	22	M12x1.25	16	M16x1.5	22	34	18	21	22					
40	1	18	M14x1.5	18	-	-	M12x1.25	18	30	15	17	16	35	3	62	6	10
	2	28	M20x1.5	28	M14x1.5	18	M20x1.5	28	42	22	26	22					
50	1	22	M16x1.5	22	-	-	M16x1.5	22	34	18	21	22	41	4	74	6	16
	2	36	M27x2	36	M16x1.5	22	M27x2	36	50	30	34	25					
	3	28	M20x1.5	28	M16x1.5	22	M20x1.5	28	42	22	26	22					
63	1	28	M20x1.5	28	-	-	M20x1.5	28	42	22	26	22	48	4	75	6	16
	2	45	M33x2	45	M20x1.5	28	M33x2	45	60	39	43	29					
	3	36	M27x2	36	M20x1.5	28	M27x2	36	50	30	34	25					
80	1	36	M27x2	36	-	-	M27x2	36	50	30	34	25	51	4	82	5	20
	2	56	M42x2	56	M27x2	36	M42x2	56	72	48	54	29					
	3	45	M33x2	45	M27x2	36	M33x2	45	60	39	43	29					
100	1	45	M33x2	45	-	-	M33x2	45	60	39	43	29	57	5	92	7	22
	2	70	M48x2	63	M33x2	45	M48x2	63	88	62	68	32					
	3	56	M42x2	56	M33x2	45	M42x2	56	72	48	54	29					
125	1	56	M42x2	56	-	-	M42x2	56	72	48	54	29	57	5	105	9	20
	2	90	M64x3	85	M42x2	56	M64x3	85	108	80	88	32					
	3	70	M48x2	63	M42x2	56	M48x2	63	88	62	68	32					
160	1	70	M48x2	63	-	-	M48x2	63	88	62	68	32	57	5	125	10	22
	2	110	M80x3	95	M48x2	63	M80x3	95	133	100	108	32					
	3	90	M64x3	85	M48x2	63	M64x3	85	108	80	88	32					
200	1	90	M64x3	85	-	-	M64x3	85	108	80	88	32	57	5	150	10	22
	2	140	M100x3	112	M64x3	85	M100x3	112	163	128	138	32					
	3	110	M80x3	95	M64x3	85	M80x3	95	133	100	108	32					

All dimensions are in millimeters unless otherwise stated.

For Cylinder Division Plant Locations – See Page II.



Parker Series HMI Metric Hydraulic Cylinders

Extended Tie Rod Mountings

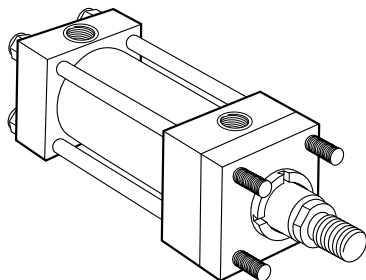

Style TB
Tie Rods Extended Head End
(ISO Style MX3)

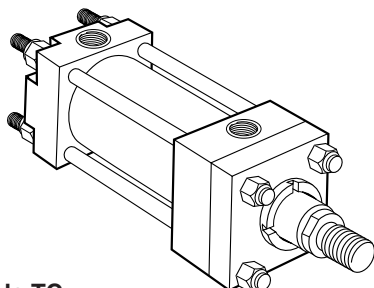
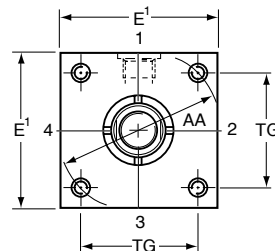
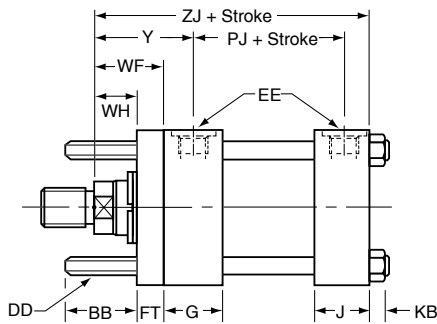

Style TC
Tie Rods Extended Cap End
(ISO Style MX2)

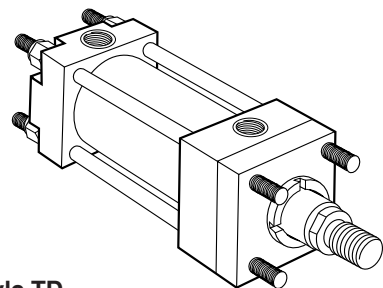
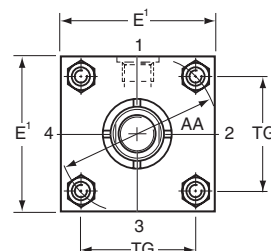
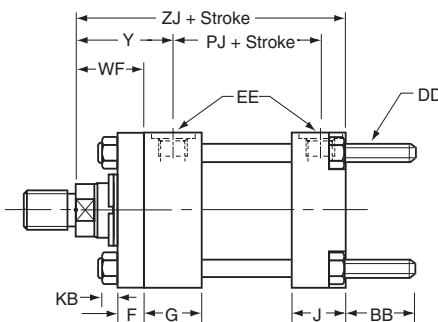

Style TD
Tie Rods Extended Both Ends
(ISO Style MX1)

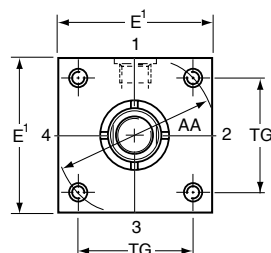
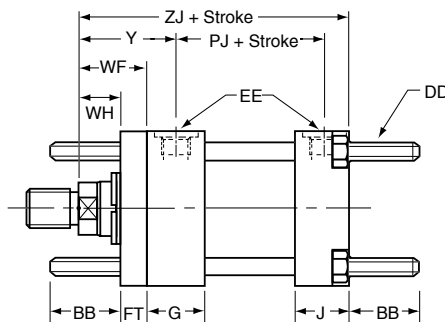

¹Head depth increased by 5mm to accommodate port on 25mm and 32mm bore cylinders – see page 111

Dimensions – TB, TC & TD See also Rod End Dimensions, page 111

Bore φ	AA	BB	DD	E	EE BSP/G inches	F	FT	G	J	KB	TG	WF	WH	Y	+ Stroke	
															PJ	ZJ
25	40	19	M5x0.8	40 ¹	1/4	10	10	40	25	4	28.3	25	15	50	53	114
32	47	24	M6x1	45 ¹	1/4	10	10	40	25	5	33.2	35	25	60	56	128
40	59	35	M8x1	63	3/8	10	10	45	38	6.5	41.7	35	25	62	73	153
50	74	46	M12x1.25	75	1/2	16	16	45	38	10	52.3	41	25	67	74	159
63	91	46	M12x1.25	90	1/2	16	16	45	38	10	64.3	48	32	71	80	168
80	117	59	M16x1.5	115	3/4	20	20	50	45	13	82.7	51	31	77	93	190
100	137	59	M16x1.5	130	3/4	22	22	50	45	13	96.9	57	35	82	101	203
125	178	81	M22x1.5	165	1	22	22	58	58	18	125.9	57	35	86	117	232
160	219	92	M27x2	205	1	25	25	58	58	22	154.9	57	32	86	130	245
200	269	115	M30x2	245	1-1/4	25	25	76	76	24	190.2	57	32	98	165	299

All dimensions are in millimeters unless otherwise stated.

For additional information – call your local Parker Cylinder Distributor.

Parker Series HMI Metric Hydraulic Cylinders

Flange and Side Lugs Mountings

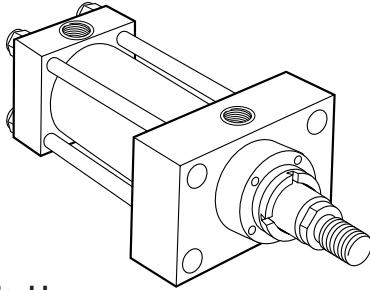

Style JJ
Head Rectangular Flange
(ISO Style ME5)

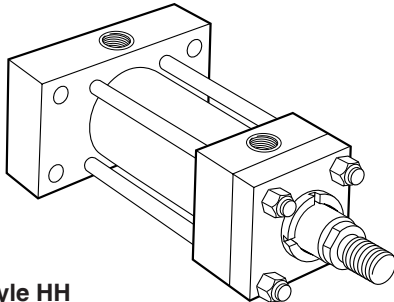
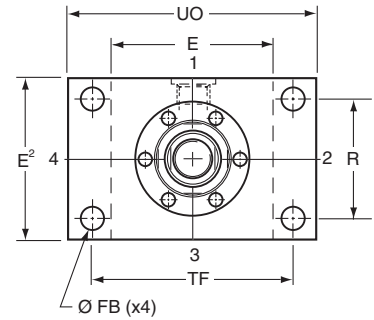
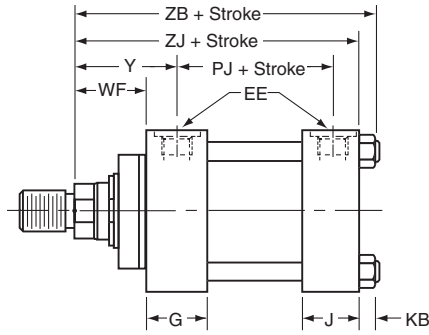

Style HH
Cap Rectangular Flange
(ISO Style ME6)

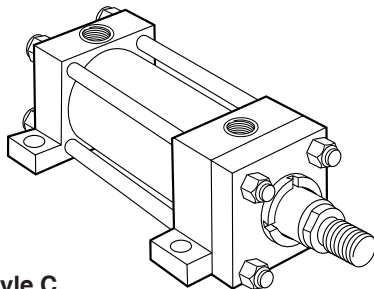
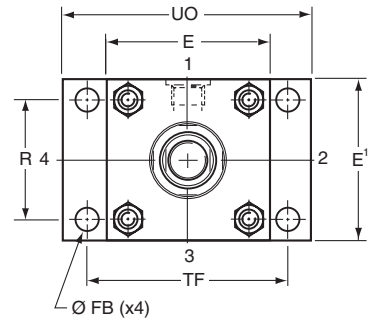
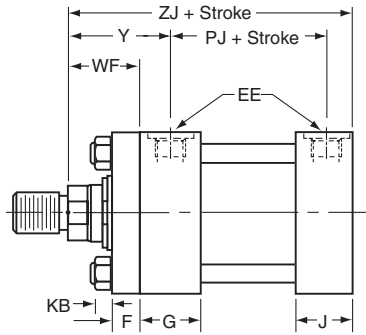

Style C
Side Lugs
(ISO Style MS2)

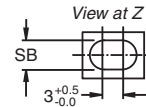
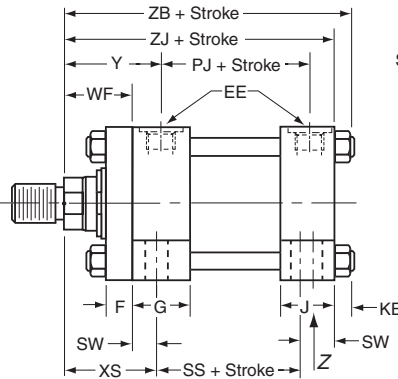

A thrust key may be used with this mounting style.

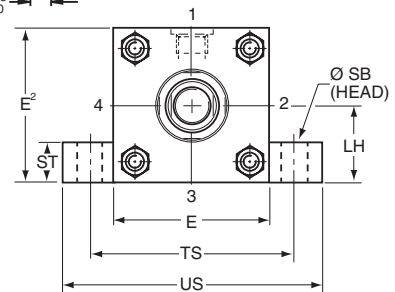

¹Head depth increased by 5mm to accommodate port on 25mm and 32mm bore cylinders – see page 111.

²On 25mm and 32 mm bore C mount and JJ mount cylinders with port in position 2 or 4, head depth E is increased by 5mm in position 1.

Dimensions – JJ, HH & C See also Rod End Dimensions, page 111

Bore φ	E	EE BSP/G inches	F	FB	G	J	KB	LH	R	SB	ST	SW	TF	TS	UO	US	WF	XS	Y	+ Stroke			
																				PJ	SS	ZB	ZJ
25	40 ¹	1/4	10	5.5	40	25	4	19	27	6.6	8.5	8	51	54	65	72	25	33	50	53	72	121	114
32	45 ¹	1/4	10	6.6	40	25	5	22	33	9	12.5	10	58	63	70	84	35	45	60	56	72	137	128
40	63	3/8	10	11	45	38	6.5	31	41	11	12.5	10	87	83	110	103	35	45	62	73	97	166	153
50	75	1/2	16	14	45	38	10	37	52	14	19	13	105	102	130	127	41	54	67	74	91	176	159
63	90	1/2	16	14	45	38	10	44	65	18	26	17	117	124	145	161	48	65	71	80	85	185	168
80	115	3/4	20	18	50	45	13	57	83	18	26	17	149	149	180	186	51	68	77	93	104	212	190
100	130	3/4	22	18	50	45	13	63	97	26	32	22	162	172	200	216	57	79	82	101	101	225	203
125	165	1	22	22	58	58	18	82	126	26	32	22	208	210	250	254	57	79	86	117	130	260	232
160	205	1	25	26	58	58	22	101	155	33	38	29	253	260	300	318	57	86	86	130	129	279	245
200	245	1-1/4	25	33	76	76	24	122	190	39	44	35	300	311	360	381	57	92	98	165	171	336	299

All dimensions are in millimeters unless otherwise stated.

For Cylinder Division Plant Locations – See Page II.



Parker Series HMI Metric Hydraulic Cylinders

Pivot Mountings

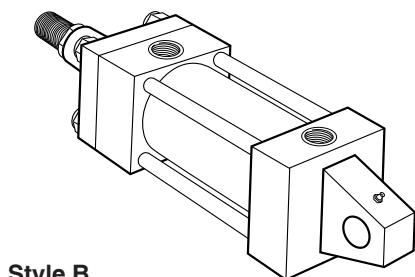

Style B
Cap Fixed Eye
(ISO Style MP3)

Pivot pin not supplied

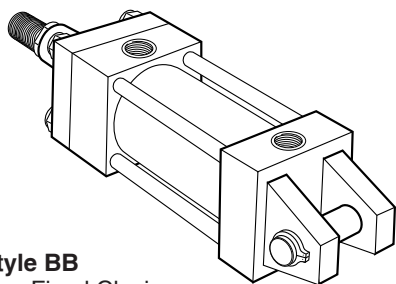
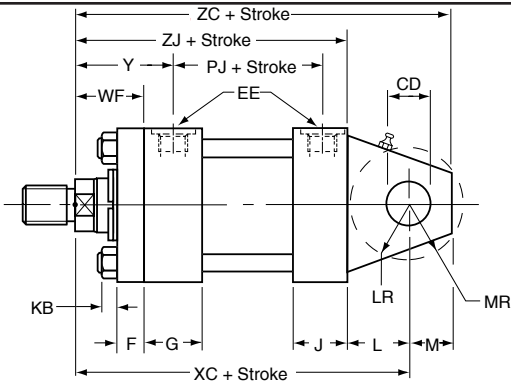
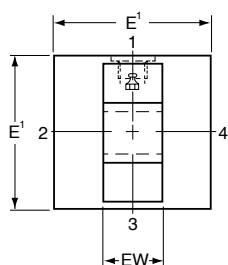

Style BB
Cap Fixed Clevis
(ISO Style MP1)

Supplied complete with pivot pin

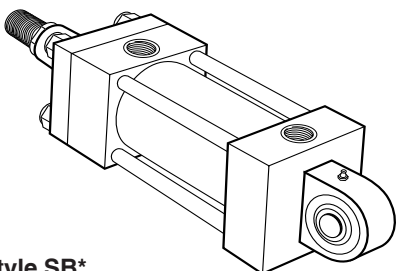
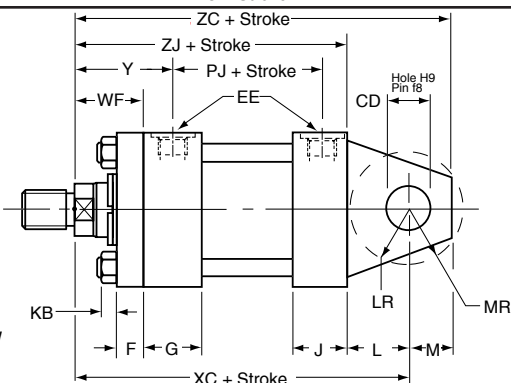
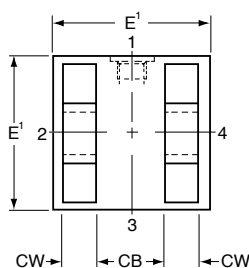

Style SB*
Cap Fixed Eye
(ISO Style MP5)

Pivot pin not supplied

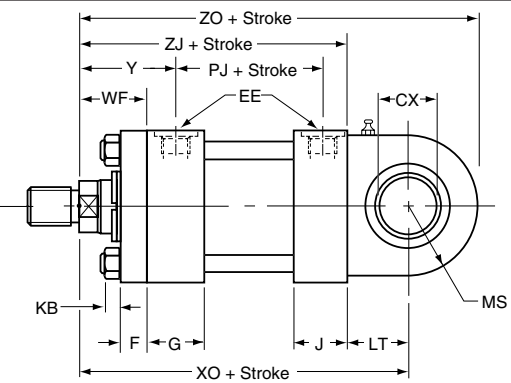
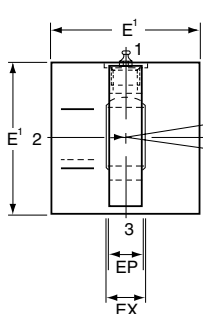

*Head depth increased by 5mm to accommodate port on 25mm and 32mm bore cylinders – see page 111

*Parker Style SB is also known as Style SBd under Parker's European model code system

Dimensions – B, BB & SB See also Rod End Dimensions, page 111

Bore φ	CB A16	CD H9	CW	CX	E	EE BSP/G inches	EP h14	EW	EX	F	G	J	KB	L	LR	LT	M	MR	MS max	WF	Y	+ Stroke					
																						PJ	XC	XO	ZC	ZJ	ZO
25	12	10	6	12-0.008	40 ¹	1/4	8	12	10	10	40	25	4	13	12	16	10	12	20	25	50	53	127	130	137	114	150
32	16	12	8	16-0.008	45 ¹	1/4	11	16	14	10	40	25	5	19	17	20	12	15	22.5	35	60	56	147	148	159	128	170.5
40	20	14	10	20-0.012	63	3/8	13	20	16	10	45	38	6.5	19	17	25	14	16	29	35	62	73	172	178	186	153	207
50	30	20	15	25-0.012	76	1/2	17	30	20	16	45	38	10	32	29	31	20	25	33	41	67	74	191	190	211	159	223
63	30	20	15	30-0.012	90	1/2	19	30	22	16	45	38	10	32	29	38	20	25	40	48	71	80	200	206	220	168	246
80	40	28	20	40-0.012	115	3/4	23	40	28	20	50	45	13	39	34	48	28	34	50	51	77	93	229	238	257	190	288
100	50	36	25	50-0.012	130	3/4	30	50	35	22	50	45	13	54	50	58	36	44	62	57	82	101	257	261	293	203	323
125	60	45	30	60-0.015	165	1	38	60	44	22	58	58	18	57	53	72	45	53	80	57	86	117	289	304	334	232	384
160	70	56	35	80-0.015	205	1	47	70	55	25	58	58	22	63	59	92	59	59	100	57	86	130	308	337	367	245	437
200	80	70	40	100-0.020	245	1-1/4	57	80	70	25	76	76	24	82	78	116	70	76	120	57	98	165	381	415	451	299	535

All dimensions are in millimeters unless otherwise stated.

For additional information – call your local Parker Cylinder Distributor.

Parker Series HMI Metric Hydraulic Cylinders

Trunnion Mountings

Style D
Head Trunnion
(ISO Style MT1)

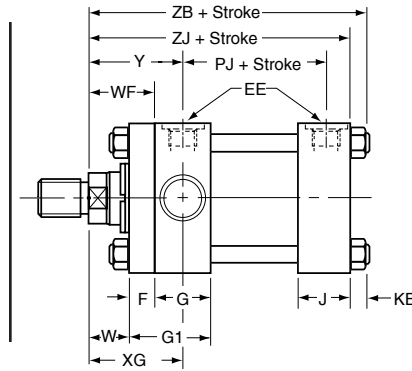
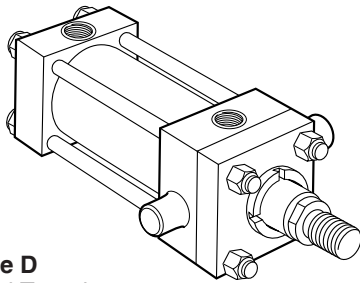

Notes:

A one-piece head and retainer is used on 100mm-200mm bore sizes – G1 dimension. On 160 and 200mm bores, the bolted gland is recessed, with tie rods screwed into the head.

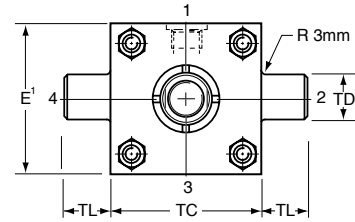

Style DB
Cap Trunnion
(ISO Style MT2)

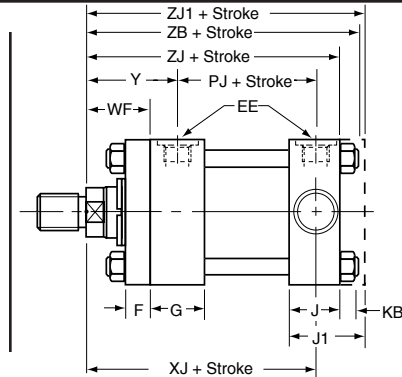
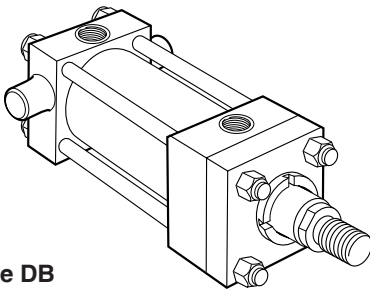

Note:

On 100-200mm bore cylinders, dimension J becomes J1. ZJ1 replaces ZB, and tie rods are screwed directly into the cap.

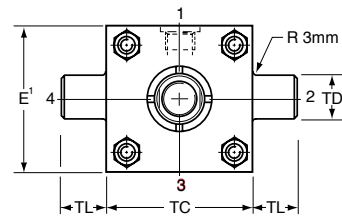

Style DD
Intermediate Fixed Trunnion
(ISO Style MT4)

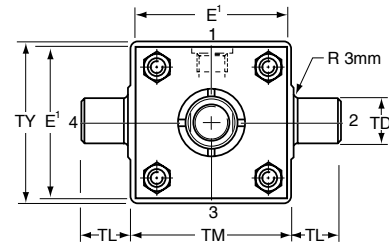
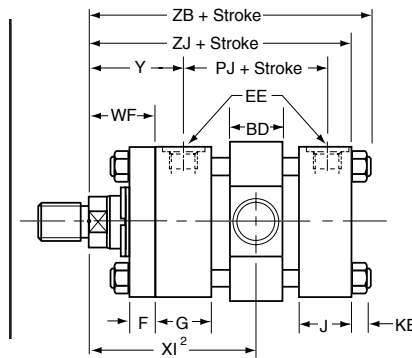
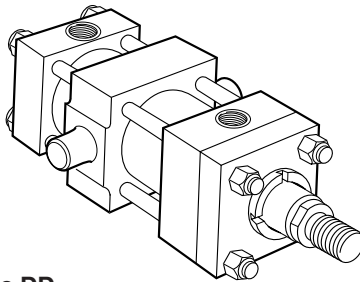

¹Head depth increased by 5mm to accommodate port on 25mm and 32mm bore cylinders – see page 111

²Dimensions to be specified by customer

Dimensions – D, DB & DD See also Rod End Dimensions, page 111

Bore φ	BD	E	EE BSP/G inches	F	G	G1	J	J1	KB	TC	TD	TL	TM	TY	W	WF	XG	Y	+ Stroke					Style DD min stroke	Min XI dim'n
																			PJ	XJ	ZJ	ZJ1	ZB		
25	20	40 ¹	1/4	10	40	-	25	-	4	38	12	10	48	45	-	25	44	50	53	101	114	-	121	10	78
32	25	45 ¹	1/4	10	40	-	25	-	5	44	16	12	55	54	-	35	54	60	56	115	128	-	137	10	90
40	30	63	3/8	10	45	-	38	-	6.5	63	20	16	76	76	-	35	57	62	73	134	153	-	166	15	97
50	40	76	1/2	16	45	-	38	-	10	76	25	20	89	89	-	41	64	67	74	140	159	-	176	15	107
63	40	90	1/2	16	45	-	38	-	10	89	32	25	100	95	-	48	70	71	80	149	168	-	185	15	114
80	50	115	3/4	20	50	-	45	50	13	114	40	32	127	127	-	51	76	77	93	168	190	194	212	20	127
100	60	130	3/4	22	50	72	45	58	13	127	50	40	140	140	35	57	71	82	101	187	203	216	225	20	138
125	73	165	1	22	58	80	58	71	18	165	63	50	178	178	35	57	75	86	117	209	232	245	260	25	153
160	90	205	1	25	58	88	58	88	22	203	80	63	215	216	32	57	75	86	130	230	245	275	279	30	161
200	110	245	1-1/4	25	76	108	76	108	24	241	100	80	279	280	32	57	85	98	165	276	299	330	336	30	190

All dimensions are in millimeters unless otherwise stated.

For Cylinder Division Plant Locations – See Page II.



Parker Series HMI Metric Hydraulic Cylinders

Double Rod Cylinders

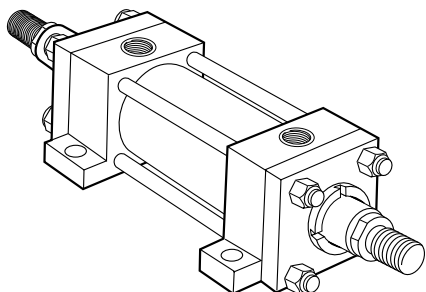

Double Rod Cylinder

Available with Styles TB, TD, JJ, C, D, DD (Style C illustrated)

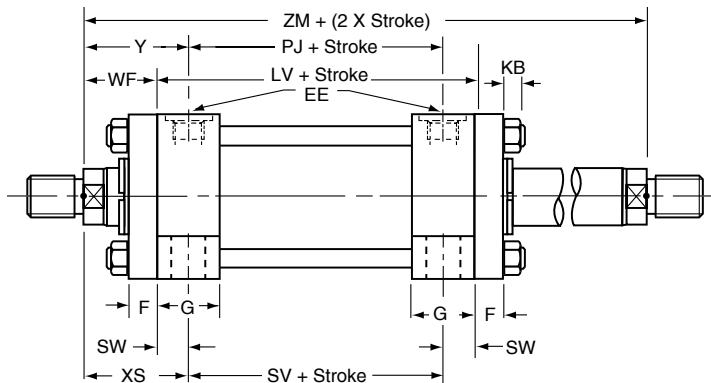

Mounting Styles and Codes

Double rod cylinders are denoted by a 'K' in the ISO cylinder model code.

Dimensions

To obtain dimensional information for double rod cylinders, first select the desired mounting style by referring to the corresponding single rod model. Dimensions for the appropriate single rod model should be supplemented by those from the table opposite to provide a full set of dimensions.

Minimum Stroke Length – Style 9 Rod End

Where a style 9 (female) piston rod end is required on a double rod cylinder with a stroke of 80mm or less, and a bore of 80mm or above, please consult the factory.

Cushioning

Double rod cylinders can be supplied with cushions at either or both ends. Cushioning requirements should be specified by inserting a 'C' in the ordering code. See cushioning section, Section C of this catalog.

Double Rod Cylinders

For double rod cylinders, specify rod number and rod end symbols for both piston rods. A typical model number for a double rod cylinder would be:

100	K	JJ	HMI	R	E	1	4	M	1	4	M	125	M	11	44
-----	---	----	-----	---	---	---	---	---	---	---	---	-----	---	----	----

Bore φ	Rod		Add Stroke			Add 2x Stroke
	No.	MM φ	LV	PJ	SV	ZM
25	1	12	104	53	88	154
	2	18				
32	1	14	108	56	88	178
	2	22				
40	1	18	125	73	105	195
	2	28				
50	1	22	125	74	99	207
	2	36				
	3	28				
63	1	28	127	80	93	223
	2	45				
	3	36				
80	1	36	144	93	110	246
	2	56				
	3	45				
100	1	45	151	101	107	265
	2	70				
	3	56				
125	1	56	175	117	131	289
	2	90				
	3	70				
160	1	70	188	130	130	302
	2	110				
	3	90				
200	1	90	242	160	172	356
	2	140				
	3	110				

All dimensions are in millimeters unless otherwise stated.

For additional information – call your local Parker Cylinder Distributor.

Parker Series HMI Metric Hydraulic Cylinders

Accessory Selection

Accessories for the rod end of a cylinder are selected by reference to the rod end thread, while the same accessories, when used at the cap end, are selected by cylinder bore size. See tables of part numbers below, and on the following pages.

The rod clevises, plain rod eyes and spherical bearings fitted as accessories to the rod end have the same pin diameters as those used at the cylinder cap ends of the corresponding mounting styles – B, BB and SB – when fitted with the No. 1 rod, or the No. 2 or No. 3 rods with Style 7 rod end.

Rod and Cap End Accessories

Accessories for the HMI ISO cylinder include:

- Rod End** – rod clevis, eye bracket and pivot pin
 – plain rod eye, clevis bracket and pivot pin
 – rod eye with spherical bearing

- Cap End** – eye bracket for style BB mounting
 – clevis bracket for style B mounting
 – pivot pin for eye bracket and clevis bracket

Rod Clevis, Eye Bracket and Pivot Pin

Thread KK	Rod Clevis	Eye Bracket	Pivot Pin	Nominal Force kN	Weight kg
M10x1.25	143447	144808	143477	8	0.3
M12x1.25	143448	144809	143478	12.5	0.6
M14x1.5	143449	144810	143479	20	0.8
M16x1.5	143450	144811	143480	32	2.2
M20x1.5	143451	144812	143480	50	2.7
M27x2	143452	144813	143481	80	5.9
M33x2	143453	144814	143482	125	9.4
M42x2	143454	144815	143483	200	17.8
M48x2	143455	144816	143484	320	26.8
M64x3	143456	144817	143485	500	39.0

Rod Clevis Dimensions

Part No.	AV	CE	CK H9	CL	CM A16	CR	ER	KK	LE	Weight kg
143447	14	32	10	26	12	20	12	M10x1.25	14	0.08
143448	16	36	12	34	16	32	17	M12x1.25	19	0.25
143449	18	38	14	42	20	30	17	M14x1.5	19	0.32
143450	22	54	20	62	30	50	29	M16x1.5	32	1.0
143451	28	60	20	62	30	50	29	M20x1.5	32	1.1
143452	36	75	28	83	40	60	34	M27x2	39	2.3
143453	45	99	36	103	50	80	50	M33x2	54	2.6
143454	56	113	45	123	60	102	53	M42x2	57	5.5
143455	63	126	56	143	70	112	59	M48x2	63	7.6
143456	85	168	70	163	80	146	78	M64x3	83	13.0

Eye Bracket Dimensions

Part No.	CK H9	EM h13	FL	MR max	LE min	AA	HB	TG	UD
144808	10	12	23	12	13	40	5.5	28.3	40
144809	12	16	29	17	19	47	6.6	33.2	45
144810	14	20	29	17	19	59	9	41.7	65
144811	20	30	48	29	32	74	13.5	52.3	75
144812	20	30	48	29	32	91	13.5	64.3	90
144813	28	40	59	34	39	117	17.5	82.7	115
144814	36	50	79	50	54	137	17.5	96.9	130
144815	45	60	87	53	57	178	26	125.9	165
144816	56	70	103	59	63	219	30	154.9	205
144817	70	80	132	78	82	269	33	190.2	240

Pivot Pin for Clevis Bracket and Plain Rod Eye – Dimensions

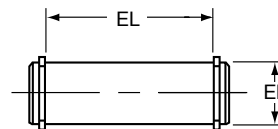

Part No.	EK f8	EL	Weight kg
143477	10	29	0.02
143478	12	37	0.05
143479	14	45	0.08
143480	20	66	0.2
143481	28	87	0.4
143482	36	107	1.0
143483	45	129	1.8
143484	56	149	4.2
143485	70	169	6.0

Eye Bracket – Cap End Mounting for Style BB

Bore ϕ	Eye Bracket	Nominal Force kN	Weight kg
25	144808	8	0.2
32	144809	12.5	0.3
40	144810	20	0.4
50	144811	32	1.0
63	144812	50	1.4
80	144813	80	3.2
100	144814	125	5.6
125	144815	200	10.5
160	144816	320	15.0
200	144817	500	20.0

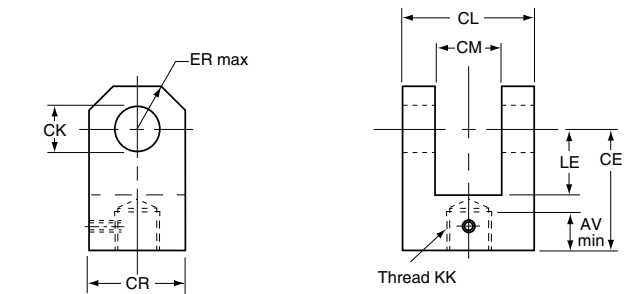

Rod Clevis

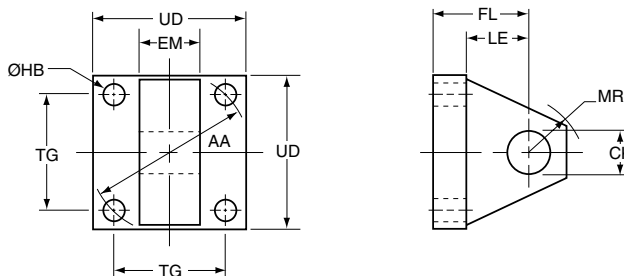

Eye Bracket

All dimensions are in millimeters unless otherwise stated.

For Cylinder Division Plant Locations – See Page II.



B

Parker Series HMI Metric Hydraulic Cylinders

Accessories

Plain Rod Eye, Clevis Bracket and Pivot Pin

Thread KK	Plain Rod Eye	Clevis Bracket	Pivot Pin	Nominal Force kN	Weight kg
M10x1.25	143457	143646	143477	8	0.5
M12x1.25	143458	143647	143478	12.5	1.0
M14x1.5	143459	143648	143479	20	1.3
M16x1.5	143460	143649	143480	32	3.2
M20x1.5	143461	143649	143480	50	3.8
M27x2	143462	143650	143481	80	6.9
M33x2	143463	143651	143482	125	12.5
M42x2	143464	143652	143483	200	26.0
M48x2	143465	143653	143484	320	47.0
M64x3	143466	143654	143485	500	64.0

Plain Rod Eye/Knuckle Dimensions

Part No.	AW	CA	CB	CD	CK H9	EM h13	ER	KK	LE	Weight kg
143457	14	32	18	9	10	12	12	M10x1.25	13	0.08
143458	16	36	22	11	12	16	17	M12x1.25	19	0.15
143459	18	38	20	12.5	14	20	17	M14x1.5	19	0.22
143460	22	54	30	17.5	20	30	29	M16x1.5	32	0.5
143461	28	60	30	20	20	30	29	M20x1.5	32	1.1
143462	36	75	40	25	28	40	34	M27x2	39	1.5
143463	45	99	50	35	36	50	50	M33x2	54	2.5
143464	56	113	65	50	45	60	53	M42x2	57	4.2
143465	63	126	90	56	56	70	59	M48x2	63	11.8
143466	85	168	110	70	70	80	78	M64x3	83	17.0

Clevis Bracket Dimensions

Part No.	CK H9	CM A16	CW	FL	MR max	HB	LE min	RC	TB	UR	UH
143646	10	12	6	23	12	5.5	13	18	47	35	60
143647	12	16	8	29	17	6.6	19	24	57	45	70
143648	14	20	10	29	17	9	19	30	68	55	85
143649	20	30	15	48	29	13.5	32	45	102	80	125
143650	28	40	20	59	34	17.5	39	60	135	100	170
143651	36	50	25	79	50	17.5	54	75	167	130	200
143652	45	60	30	87	53	26	57	90	183	150	230
143653	56	70	35	103	59	30	63	105	242	180	300
143654	70	80	40	132	78	33	82	120	300	200	360

Clevis Bracket – For Style B

Bore φ	Clevis Bracket	Nominal Force kN	Weight kg
25	143646	8	0.4
32	143647	12.5	0.8
40	143648	20	1.0
50	143649	32	2.5
63	143649	50	2.5
80	143650	80	5.0
100	143651	125	9.0
125	143652	200	20.0
160	143653	320	31.0
200	143654	500	41.0

Plain Rod Eye/Knuckle

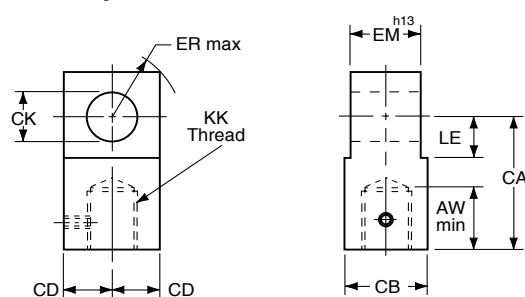

Clevis Bracket

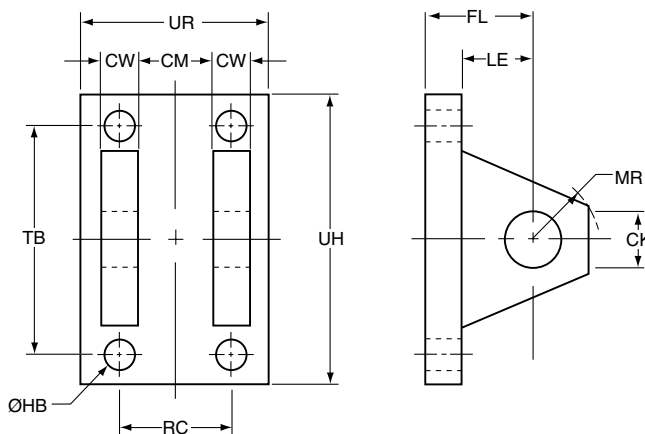

Pivot Pin for Clevis Bracket and Plain Rod Eye – Dimensions

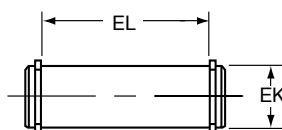

Part No.	EK f8	EL	Weight kg
143477	10	29	0.02
143478	12	37	0.05
143479	14	45	0.08
143480	20	66	0.2
143481	28	87	0.4
143482	36	107	1.0
143483	45	129	1.8
143484	56	149	4.2
143485	70	169	6.0

All dimensions are in millimeters unless otherwise stated.

For additional information – call your local Parker Cylinder Distributor.

Parker Series HMI Metric Hydraulic Cylinders

Accessories

Rod Eye with Spherical Bearing, Mounting Bracket and Pivot Pin

Thread KK	Rod Eye with Spherical Bearing	Mounting Bracket and Pivot Pin	Nominal Force kN	Weight kg
M10x1.25	145254	145530	8	0.2
M12x1.25	145255	145531	12.5	0.3
M14x1.5	145256	145532	20	0.4
M16x1.5	145257	145533	32	0.7
M20x1.5	145258	145534	50	1.3
M27x2	145259	145535	80	2.3
M33x2	145260	145536	125	4.4
M42x2	145261	145537	200	8.4
M48x2	145262	145538	320	15.6
M64x3	145263	145539	500	28.0

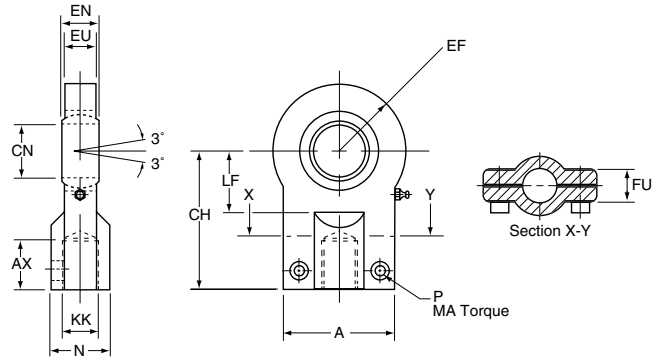

Rod Eye with Spherical Bearing

All spherical bearings should be re-packed with grease when servicing. In unusual or severe working conditions, consult the factory regarding the suitability of the bearing chosen.

Rod Eye with Spherical Bearing Dimensions

Part No.	A max	AX min	EF max	CH	CN	EN	EU	FU	KK	LF min	N max	MA max Nm	P
145254	40	15	20	42	12 -0.008	10 -0.012	8	13	M10x1.25	16	17	10	M6
145255	45	17	22.5	48	16 -0.008	14 -0.012	11	13	M12x1.25	20	21	10	M6
145256	55	19	27.5	58	20 -0.012	16 -0.012	13	17	M14x1.5	25	25	25	M8
145257	62	23	32.5	68	25 -0.012	20 -0.012	17	17	M16x1.5	30	30	25	M8
145258	80	29	40	85	30 -0.012	22 -0.012	19	19	M20x1.5	35	36	45	M10
145259	90	37	50	105	40 -0.012	28 -0.012	23	23	M27x2	45	45	45	M10
145260	105	46	62.5	130	50 -0.012	35 -0.012	30	30	M33x2	58	55	80	M12
145261	134	57	80	150	60 -0.015	44 -0.015	38	38	M42x2	68	68	160	M16
145262	156	64	102.5	185	80 -0.015	55 -0.015	47	47	M48x2	92	90	310	M20
145263	190	86	120	240	100 -0.020	70 -0.020	57	57	M64x3	116	110	530	M24

Mounting Bracket and Pivot Pin Dimensions - For Style SB

Part No.	CF K7/h6	CG +0.1, +0.3	CO N9	CP	FM js11	FO js14	GL js13	HB	KC 0, +0.30	LG	LJ	LO	RE js13	SR max	TA js13	UJ	UK
145530	12	10	10	30	40	16	46	9	3.3	28	29	56	55	12	40	75	60
145531	16	14	16	40	50	18	61	11	4.3	37	38	74	70	16	55	95	80
145532	20	16	16	50	55	20	64	14	4.3	39	40	80	85	20	58	120	90
145533	25	20	25	60	65	22	78	16	5.4	48	49	98	100	25	70	140	110
145534	30	22	25	70	85	24	97	18	5.4	62	63	120	115	30	90	160	135
145535	40	28	36	80	100	24	123	22	8.4	72	73	148	135	40	120	190	170
145536	50	35	36	100	125	35	155	30	8.4	90	92	190	170	50	145	240	215
145537	60	44	50	120	150	35	187	39	11.4	108	110	225	200	60	185	270	260
145538	80	55	50	160	190	35	255	45	11.4	140	142	295	240	80	260	320	340
145539	100	70	63	200	210	35	285	48	12.4	150	152	335	300	100	300	400	400

Cap Mounting Bracket and Pivot Pin

Bore ϕ	Mounting Bracket and Pivot Pin	Nominal Force kN	Weight kg
25	145530	8	0.6
32	145531	12.5	1.3
40	145532	20	2.1
50	145533	32	3.2
63	145534	50	6.5
80	145535	80	12.0
100	145536	125	23.0
125	145537	200	37.0
160	145538	320	79.0
200	145539	500	140.0

Mounting Bracket and Pivot Pin

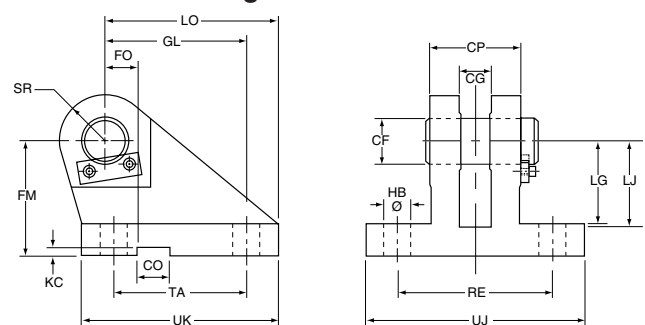

All dimensions are in millimeters unless otherwise stated.

For Cylinder Division Plant Locations – See Page II.



How to Order ISO Cylinders

Data Required On All Cylinder Orders

When ordering Series HMI cylinders, be sure to specify each of the following requirements:

(NOTE: – Duplicate cylinders can be ordered by giving the SERIAL NUMBER from the nameplate of the original cylinder. Factory records supply a quick, positive identification.)

a) Bore Size

b) Mounting Style

Specify your choice of mounting style – as shown and dimensioned in this catalog. If double rod is required, specify “with double rod.”

c) Series Designation (“HMI”)

d) Length of Stroke

e) Piston Rod Diameter

Call out rod diameter or rod code number. In Series HMI cylinders, standard rod diameters (Code No. 1) will be furnished if not otherwise specified, unless length of stroke makes the application questionable.

f) Piston Rod End Thread Style

Call out thread style number or specify dimensions. Thread style number 4 will be furnished if not otherwise specified.

g) Cushions (if required)

Specify “Cushion-head end,” “Cushion-cap end” or “Cushion-both ends” as required. If cylinder is to have a double rod and only one cushion is required, be sure to specify clearly which end of the cylinder is to be cushioned.

h) Piston

Parker B style pistons are standard. Fluorocarbon also available.

i) Ports

BSP (ISO 228) are standard.

j) Fluid Medium

Series HMI hydraulic cylinders are equipped with seals for use with hydraulic oil. If other than hydraulic oil will be used, consult factory.

ADDITIONAL DATA is required on orders for cylinders with special modifications.
For further information, consult factory.

Service Policy

On cylinders returned to the factory for repairs, it is standard policy for the Cylinder Division to make such part replacements as will put the cylinder in as good as new condition. Should the condition of the returned cylinder be such that expenses for repair would exceed the costs of a new one, you will be notified.

Address all correspondence to Service Department at your nearest regional plant listed in the pages of this catalog.

Certified Dimensions

Parker Cylinder Division guarantees that all cylinders ordered from this catalog will be built to dimensions shown. All dimensions are certified to be correct, and thus it is not necessary to request certified drawings.

For additional information – call your local Parker Cylinder Distributor.

