

Vacuum System Peripherals

Vacuum regulator, Electronic vacuum regulator, Directional control valve, Vacuum pressure switch, Pressure gauge for vacuum, Flow control equipment

Vacuum Regulator

Vacuum regulator: IRV P.1276

Electronic Vacuum Regulator

Electronic vacuum regulator: ITV209□ P.1277

Directional Control Valve

Selection guide of directional control valve (Ejector system/Vacuum pump system) P.1278
V100/SYJ/VQZ/VK/VKF P.1280
VX2/VX3 P.1281
VT/VP/VG/VNB P.1282
VEX3/VQD1000-V P.1283
SJ3A6 P.1284

Vacuum Pressure Switch

1. ZSE30/ZSE40/ZSE80/ZSE50F P.1285
2. ZSE60F/ZSE3/ZSE1/ZSE2 P.1286
3. PS1100/ZSP1/PSE200/300/530 P.1287
4. PSE540/PFM P.1288

Pressure Gauge for Vacuum

Pressure gauge for vacuum: GZ46 P.1289

Flow Control Equipment

1. Speed controller: AS P.1290
2. Check valve: AK P.1290
3. Check valve with one-touch fitting: AKH P.1290
4. Check valve, Bushing type: AKB P.1290

Made to Order

1. Vacuum release valve with throttle valve: SY5A2R P.1291
2. Vacuum release valve with throttle valve: SV1A4R-X8 P.1295
3. Air suction filter (Filter volume: 1cm³): FGZG220A P.1296

ZA

ZX

ZR

ZM

ZMA

ZQ

ZH

ZU

ZL

ZY□

ZF□

ZP□

SP

ZCUK

AMJ

AMV

AEP

HEP

Related
Equipment

Vacuum System Peripherals: Vacuum Regulator: *IRV1000/2000/3000*

Refer to Best Pneumatics No. 5 for details.

Allows adjustment of vacuum line pressure



Specifications

Model	IRV1000	IRV2000	IRV3000
Fluid	Air		
Set pressure range ⁽¹⁾	-100 to -1.3 kPa		
Atmospheric intake consumption ⁽²⁾	0.6 ℓ/min (ANR) or less		1.1 ℓ/min (ANR) or less
Knob resolution	0.13 kPa or less		
Ambient and fluid temperature	5 to 60°C		
Port size	Rc 1/8	Rc 1/4	Rc 1/4, 3/8, 1/2
Pressure gauge port size	Rc 1/8 (2 locations)		
Mass (kg) [without accessory]	0.12	0.27	0.7

Note 1) Note that the pressure range fluctuates depending on the vacuum pump pressure.
Note 2) Air is always supplied from the atmosphere.

How to Order

IRV 1 000 - 01 - -

Vacuum regulator

Body size

1	IRV1000
2	IRV2000
3	IRV3000

Thread type

Nil	Rc
N*	NPT
F*	G

* Option

Pressure gauge position

Nil: Standard

R: Rear pressure gauge mounting

Accessory

Nil	None
B	With bracket <small>Note)</small>
G	With pressure gauge

Note) Brackets are shipped together (but not assembled).

Port size

Symbol	Size	Applicable model		
		IRV1000	IRV2000	IRV3000
01	1/8	●	—	—
02	1/4	—	●	●
03	3/8	—	—	●
04	1/2	—	—	●

Combinations

◎Standard specification ○Valid combination □ Invalid combination

Specifications	Symbol	Applicable model		
		IRV1000	IRV2000	IRV3000
Standard specifications	Connection Rc 1/8	◎		
	Connection Rc 1/4		◎	◎
	Connection Rc 3/8			◎
	Connection Rc 1/2			◎
Accessory	Bracket	○	○	○
	Pressure gauge	○	○	○
Option	Rear pressure gauge mounting	○	○	○
	Connection NPT 1/8	○		
	Connection NPT 1/4		○	
	Connection NPT 3/8			○
	Connection NPT 1/2			○
	Connection G 1/8	○		
	Connection G 1/4		○	○
	Connection G 3/8			○
Connection G 1/2			○	

Vacuum System Peripherals: Electronic Vacuum Regulator: *ITV209* □

Refer to Best Pneumatics No. 5 for details.



Straight type cable connector

Right angle type cable connector

Linearity

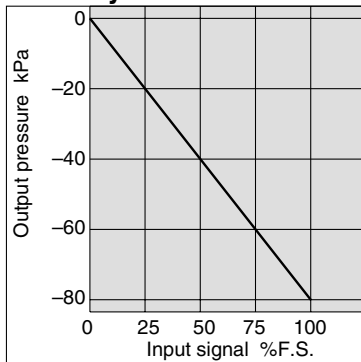

Hysteresis

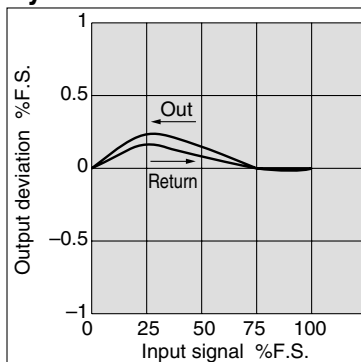

Flow Characteristics

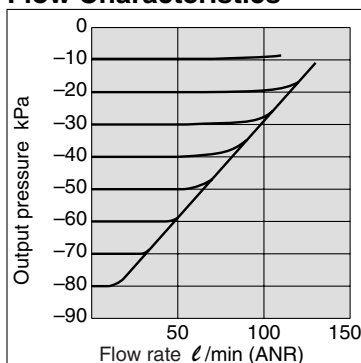

Vacuum Supply Pressure MPa: -100 kPa

Specifications

Model		ITV2090	ITV2091
Power supply	Voltage	24 VDC ±10%	12 to 15 VDC
	Current consumption	Power supply voltage 24 VDC type: 0.12 A or less Power supply voltage 12 to 15 VDC type: 0.18 A or less	
Min. supply vacuum pressure ⁽¹⁾		Set pressure -13.3 kPa	
Max. supply vacuum pressure		-101 kPa	
Set pressure range		-1.3 to -80 kPa	
Input signal	Current type ⁽²⁾	4 to 20 mA, 0 to 20 mA	
	Voltage type	0 to 5 VDC, 0 to 10 VDC	
	Preset input	4 points	
Input impedance	Current type	250 Ω or less	
	Voltage type	Approx. 6.5 kΩ	
	Preset input	Approx. 2.7 kΩ	
Output signal ⁽³⁾ (Monitor output)	Analog output ⁽⁴⁾	1 to 5 VDC (Load impedance: 1 kΩ or more) 4 to 20 mA (Sink type) (Load impedance: 250 Ω or less)	
	Switch output	NPN open collector output: Max. 30 V, 30 mA PNP open collector output: Max. 30 mA	
Linearity		Within ±1% (Full span)	
Hysteresis		Within 0.5% (Full span)	
Repeatability		Within ±0.5% (Full span)	
Sensitivity		Within 0.2% (Full span)	
Temperature characteristics		Within ±0.12% (Full span)/°C	
Output pressure display	Accuracy	±3% (Full span)	
	Units	kPa Minimum display: 1 ⁽⁵⁾	
Ambient and fluid temperature		0 to 50°C (No condensation)	
Enclosure		Equivalent to IP65	
Mass		350 g	



Note 1) The minimum supply vacuum pressure should be 13.3 kPa more than the maximum vacuum pressure setting value.

Note 2) 4 to 20 mA is not possible with the 2-wire type. Power supply voltage (24 VDC or 12 to 15 VDC) is required.

Note 3) Either analog output or switch output must be selected.

Furthermore, when switch output is selected, either NPN output or PNP output must also be selected.

Please note that the preset input type is not equipped with an output signal function.

Note 4) At the atmospheric pressure, 1 VDC or 4 mA is output. 5 VDC or 20 mA is output at the rated pressure.

Note 5) Please contact SMC regarding indication with other units of pressure.

How to Order

ITV 209 0 - 0 1 2 S 5

- Pressure range**
 - 9: -1.3 to -80 kPa
- Power supply voltage**
 - 0: 24 VDC
 - 1: 12 to 15 VDC
- Input signal**
 - 0: Current type 4 to 20 mA DC
 - 1: Current type 0 to 20 mA DC
 - 2: Voltage type 0 to 5 VDC
 - 3: Voltage type 0 to 10 VDC
 - 4*: Preset input
- Monitor output**
 - 0*: Without (In the case of preset input)
 - 1: Analog output 1 to 5 VDC
 - 2*: Switch output/NPN output
 - 3*: Switch output/PNP output
 - 4*: Analog output 4 to 20 mA DC
- Pressure display unit**
 - 5: kPa
- Cable connector type**
 - S: Straight type 3 m
 - L*: Right angle type 3 m
 - N*: Without cable connector
- Bracket**
 - Nil: Without bracket
 - B*: Flat bracket
 - C*: L-bracket
- Port size**
 - 2: 1/4
- Thread type**
 - Nil: Rc
 - N: NPT
 - T: NPTF
 - F: G

* Option

ZA

ZX

ZR

ZM

ZMA

ZQ

ZH

ZU

ZL

ZY □

ZF □

ZP □

SP

ZCUK

AMJ

AMV

AEP

HEP









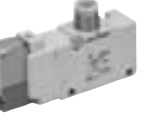

Related Equipment

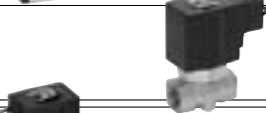
Vacuum System Peripherals: Directional Control Valve

A guide for selecting the solenoid valve model to accommodate the system
An array of solenoid valves (2/3 port valve) for controlling the ejector/external vacuum supply system

How to read the chart

The solenoid valves are available in the following constructions: the standard product (for general use), the external pilot specification, and the vacuum specification. Select the optimal model in accordance with your circuit configuration and the effective area. For detailed specifications of these products, refer to the respective catalog that is available separately.

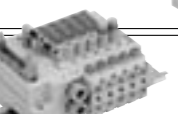
System		Ejector System						Vacuum Pump System						Caution on Model Selection				
		Vacuum release valve			Supply valve			Vacuum switching valve			Divider valve of vacuum supply air			Flow characteristics C(dm ³ /s-bar))	Effective area (mm ²)	Port size	Best Pneumatics No.	
Solenoid valve	Valve construction	Standard	External pilot spec. (R)	Vacuum spec. (V)	Standard	External pilot spec. (R)	Vacuum spec. (V)	Standard	External pilot spec. (R)	Vacuum spec. (V)	Standard	External pilot spec. (R)	Vacuum spec. (V)					
Compact 3 port solenoid valve V100, SYJ Compact size: 10 mm (V100, SYJ300) 15 mm (SYJ500) 18 mm (SYJ700) Low power consumption: 0.1 W		V100	●	-	-	●	-	-	●	-	-	●	-	-	—	0.14	M3 x 0.5 M5 x 0.8 1/8, 1/4	No.1
	SYJ300/500/700	-	●	-	-	-	●	-	-	-	●	-	-	-	0.41 to 2.8	—		
3 port solenoid valve VQZ 10 mm: VQZ100 15 mm: VQZ200 18 mm: VQZ300		VQZ100/ 200/300	-	●	-	-	●	-	-	-	-	●	-	-	1.7 to 4.5	—	M5 x 0.8 1/8, 1/4	No.1
			-	●	-	-	-	●	-	-	-	●	-	-				
3 port solenoid valve VK VKF			●	-	-	●	-	-	-	-	●	-	-	●	0.47 to 0.85	—	M5 x 0.8 1/8	No.1
			●	-	-	●	-	-	-	-	●	-	-	●				
Compact 2 port solenoid valve VX2			●	-	● ⁽¹⁾	●	-	-	● ⁽¹⁾	-	● ⁽²⁾	-	-	-	0.58 to 11	—	1/8 to 3/8	No.7
			●	-	-	●	-	-	●	-	●	-	-	●				
Compact 3 port solenoid valve VX31/32/33			●	-	-	●	-	-	● ⁽¹⁾	-	● ⁽²⁾	● ⁽¹⁾	-	● ⁽²⁾	0.29 to 1.6	—	1/8 to 3/8	No.7
			●	-	-	●	-	-	●	-	●	-	-	●				
3 port solenoid valve VT VT307/317/325			●	-	-	●	-	-	-	-	●	-	-	●	0.63 to 5.5	—	1/8 to 3/8	No.1
			●	-	-	●	-	-	-	-	●	-	-	●				
3 port solenoid valve VP VP300/500/700			-	●	-	-	●	-	-	●	-	-	●	-	2.9 to 15	—	1/8 to 1/2	No.1
			-	●	-	-	●	-	-	●	-	-	●	-				
3 port solenoid valve VG342			-	●	-	-	●	-	-	●	-	-	●	-	26 to 38	—	1/2 to 3/4	No.1
			-	●	-	-	●	-	-	●	-	-	●	-	—	210	1	
Vacuum pilot 2 port valve VNB□□□V			-	●	●	-	●	●	-	●	●	-	●	●	9.6 to 35 (VNB2 to 3)	130 to 770 (VNB4 to 7)	3/8 to 2	No.7
			-	●	●	-	●	●	-	●	●	-	●	●				
3 position valve VEX3			-	●	●	-	●	●	-	●	●	-	●	●	2.4 to 13	—	1/8 to 1/2	No.1
			-	●	●	-	●	●	-	●	●	-	●	●				
Vacuum/release unit VQD1000-V			-	-	-	-	-	-	-	-	-	-	-	-	0.27	—	M5 x 0.8	No.1
			-	-	-	-	-	-	-	-	-	-	-	-				
Vacuum release valve with throttle valve SJ3A6			-	●	-	-	●	-	-	●	-	-	●	-	0.4	—	M5 x 0.8	No.1
			-	●	-	-	●	-	-	●	-	-	●	-				

Caution on Model Selection

⚠ Caution

- Use a plug cap at R port of 2 port valve and 3 port valve for vacuum release valve and vacuum switching valve. (Except VEX 3)
- 1) Leakage 1 cm³/min or less
- 2) Leakage: 10⁻⁶ Pam³/sec (at pressure differential of 0.1 MPa)
- 3) Applications are different from vacuum holding valve.
- 4) Refer to front matter 32 of Best Pneumatics No. 1 for flow characteristics.
- 5) Conversion from sonic conductance C: Effective area S = 5.0 x C

Note 1) For up to -101.2 kPa of vacuum, it can be used as the standard product (1 cm³/min max. leakage).
Above that, it will be the V specification (10⁻⁵ cm³/sec max. leakage).

ZA
ZX
ZR
ZM
ZMA
ZQ
ZH
ZU
ZL
ZY□
ZF□
ZP□
SP
ZCUK
AMJ
AMV
AEP
HEP
Related Equipment

Vacuum System Peripherals: Directional Control Valve/Solenoid Valve

Compact 3 port solenoid valve V100, SYJ

Possible to use with vacuum up to at -100 kPa

Compact size: Width 10 mm (V100, SYJ300)

Width 15 mm (SYJ500)

Width 18 mm (SYJ700)

Low power consumption 0.1W (With energy saving circuit)

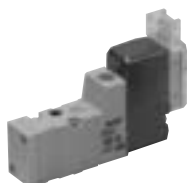

Body ported

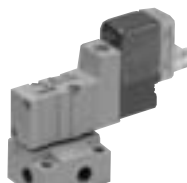

Base mounted

Model

Refer to Best Pneumatics No. 1 for details.

Piping specifications	Solenoid valve	Port size	Flow characteristics C (dm ³ /(s·bar))	Effective area (mm ²)
Body ported	SYJ312/322	M3 x 0.5	—	0.9
	SYJ512/522	M5 x 0.8	0.53	—
	SYJ712/722	1/8	2.8	—
Base mounted (With sub-plate)	V114/124 (A)	M5 x 0.8	0.037	—
	SYJ314/324	M5 x 0.8	0.41	—
	SYJ514/524	1/8	1.2	—
	SYJ714/724	1/8, 1/4	2.9	—

3 port solenoid valve VQZ100/200/300

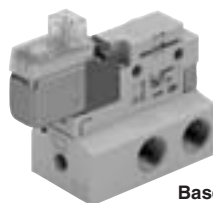

Base mounted

Model/Metal Seal, Rubber Seal

Refer to Best Pneumatics No. 1 for details.

Piping specifications	Solenoid valve	Port size	Flow characteristics C (dm ³ /(s·bar))	Effective area (mm ²)	
Base mounted (With sub-plate)	VQZ100	1/8	0.87	—	
	VQZ115		1.7		
	VQZ 200	1/8, 1/4	VQZ215	2.3	—
			VQZ235	1.7	
			VQZ225	2.5	
			VQZ245	3.0	
	VQZ 300	1/4, 3/8	VQZ315	4.5	—
			VQZ335	2.9	
			VQZ325	4.4	
			VQZ345	—	

3 port solenoid valve VK

Compact size: Width 18 mm

Possible to use with vacuum



Body ported



Base mounted

Model

Refer to Best Pneumatics No. 1 for details.

Piping specifications	Solenoid valve	Port size	Flow characteristics C (dm ³ /(s·bar))	Effective area (mm ²)
Body ported	VK332	M5 x 0.8	0.47	—
	For vacuum: VK332V *	M5 x 0.8	0.47	—
Base mounted (With sub-plate)	VK334	1/8	0.85	—
	For vacuum: VK334V *	1/8	0.85	—

* Vacuum specification: Operating pressure range -101.2 kPa to 0.1 MPa

* Low wattage style (2 W DC) and long period energized style available.

3 port solenoid valve VKF

Compact size: Width 18 mm

Possible to use with vacuum



Body ported



Base mounted

Model

Refer to Best Pneumatics No. 1 for details.

Piping specifications	Solenoid valve	Port size	Flow characteristics C (dm ³ /(s·bar))	Effective area (mm ²)
Body ported	VKF332	M5 x 0.8	0.67	—
	For vacuum: VKF332V *	M5 x 0.8	0.67	—
Base mounted (With sub-plate)	VKF334	1/8	0.68	—
	For vacuum: VKF334V *	1/8	0.68	—

* Vacuum specification: Operating pressure range -101.2 kPa to 0.1 MPa

* Low wattage style (2 W DC) and long period energized style available.

Directional Control Valve/Solenoid Valve/Vacuum System Peripherals

Compact 2 port solenoid valve Series VX2 options V & M For medium vacuum, non leakage

Leakage: 10^{-6} Pam³/sec
(at pressure differential of 0.1 MPa)
Pressure: 0.1 Pa • abs (medium vacuum)



Model

Refer to Best Pneumatics No. 7 for details.

Orifice dia. (mm ø)	Valve specifications	Model	Port size Rc	Flow characteristics C (dm ³ /(s·bar))	Effective area (mm ²)
2	N.C.	VX2110 $\frac{M}{V}$	1/8	0.59	—
	N.O.	VX2112 $\frac{M}{V}$			
3	N.C.	VX2120 $\frac{M}{V}$	1/8, 1/4	1.2	—
	N.O.	VX2122 $\frac{M}{V}$			
	N.C.	VX2220 $\frac{M}{V}$	1/4, 3/8	1.2	—
	N.O.	VX2222 $\frac{M}{V}$			
	N.C.	VX2320 $\frac{M}{V}$			
	N.O.	VX2322 $\frac{M}{V}$			
4.5	N.C.	VX2130 $\frac{M}{V}$	1/8, 1/4	2.3	—
	N.O.	VX2132 $\frac{M}{V}$			
	N.C.	VX2230 $\frac{M}{V}$	1/4, 3/8	2.3	—
	N.O.	VX2232 $\frac{M}{V}$			
	N.C.	VX2330 $\frac{M}{V}$			
	N.O.	VX2332 $\frac{M}{V}$			
6	N.C.	VX2240 $\frac{M}{V}$	1/4, 3/8	4.1	—
	N.O.	VX2242 $\frac{M}{V}$			
	N.C.	VX2340 $\frac{M}{V}$			
	N.O.	VX2342 $\frac{M}{V}$			
8	N.C.	VX2250 $\frac{M}{V}$	1/4, 3/8	6.4	—
	N.C.	VX2350 $\frac{M}{V}$			
10	N.C.	VX2260 $\frac{M}{V}$	1/4	8.8	—
			3/8, 1/2	11	—
	N.C.	VX2360 $\frac{M}{V}$	1/4	8.8	—
			3/8, 1/2	11	—

Compact 3 port solenoid valve Series VX3 options V & M For medium vacuum, non leakage

Leakage: 10^{-6} Pam³/sec
(at pressure differential of 0.1 MPa)
Pressure: 0.1 Pa • abs (medium vacuum)



Model (N.C./N.O./C.O.)

Refer to Best Pneumatics No. 7 for details.

Orifice dia. (mm ø)	Model	Port size Rc	Flow characteristics C (dm ³ /(s·bar))	Effective area (mm ²)
1.5	VX311 $\frac{0}{4} \frac{M}{V}$ -01	1/8	0.29	—
2.2	VX312 $\frac{0}{4} \frac{M}{V}$ -01		0.60	—
3	VX313 $\frac{0}{4} \frac{M}{V}$ -01		0.82	—
1.5	VX311 $\frac{0}{4} \frac{M}{V}$ -02	1/4	0.29	—
2.2	VX312 $\frac{0}{4} \frac{M}{V}$ -02		0.60	—
	VX3224 $\frac{M}{V}$ -02		0.64	—
3	VX313 $\frac{0}{4} \frac{M}{V}$ -02	3/8		0.82
	VX3234 $\frac{M}{V}$ -02		1.1	—
	VX3334 $\frac{M}{V}$ -02		—	—
4	VX3244 $\frac{M}{V}$ -02	3/8	1.6	—
	VX3344 $\frac{M}{V}$ -02			—
2.2	VX3224 $\frac{M}{V}$ -03	3/8	0.64	—
	VX3324 $\frac{M}{V}$ -03			—
3	VX3234 $\frac{M}{V}$ -03		1.1	—
	VX3334 $\frac{M}{V}$ -03			—
4	VX3244 $\frac{M}{V}$ -03		1.6	—
	VX3344 $\frac{M}{V}$ -03			—

For Vacuum Pad

Refer to Best Pneumatics No. 7 for details.

Model	Port size Rc	Orifice dia. (ø)		Flow characteristics	
		Pressurised side	Vacuum side	R→A	A→P
VXV313□	1/8, 1/4	1.5	3	0.29	0.82
VXV324□	1/4, 3/8	2.2	4	0.64	1.6
VXV334□		2.2	4		

ZA

ZX

ZR

ZM

ZMA

ZQ

ZH

ZU

ZL

ZY□

ZF□

ZP□

SP

ZCUK

AMJ

AMV

AEP

HEP

Related Equipment

Directional Control Valve/Solenoid Valve/Vacuum System Peripherals

3 port solenoid valve VT, VP



Model/Rubber Seal

Refer to Best Pneumatics No. 1 for details.

Piping specifications	Solenoid valve	Port size	Flow characteristics C (dm ³ /(s·bar))	Effective area (mm ²)
Body ported	VT325(V)	1/4, 3/8	5.5	—
	VT307(V)*	1/8, 1/4	0.71	—
	VT317(V)**	1/4	2.4	—
Body ported	VP342	1/8, 1/4	3.3	—
	VP542	1/4, 3/8	6.6	—
	VP742	3/8, 1/2	12	—
Base mounted	VP344	1/8, 1/4	2.9	—
	VP544	1/4, 3/8	6.5	—
	VP744	3/8, 1/2	12	—
Body ported	VP3145	3/8, 1/2, 3/4	19 to 28	—
	VP3165	3/4, 1, 1 1/4	—	230 to 310
	VP3185	1 1/4, 1 1/2, 2	—	570 to 650

* Low wattage (2 W DC) type and long period energized type available.

** Long period energized type available.

V: Vacuum specification: Operating pressure range -101.2 kPa to 0.1 MPa

3 port solenoid valve VG342



Model/Rubber Seal

Refer to Best Pneumatics No. 1 for details.

Piping specifications	Solenoid valve	Port size	Flow characteristics C (dm ³ /(s·bar))	Effective area (mm ²)
Body ported	VG342	1/2 to 3/4	26 to 38	—
		1	—	210
	For Vacuum: VG342R*	1/2 to 3/4	26 to 38	—
		1	—	210

* Operating pressure range: -101.2 kPa to 0.9 MPa

Vacuum pilot 2 port valve VNB□□□□V

It is used when the valve is to be operated by the main vacuum in the absence of pressurized air.

Specifications (Vacuum pilot)

Fluid	Vacuum
Operating pressure range	-101 kPa to atmospheric pressure
Pilot pressure range	-101 to -47.9 kPa

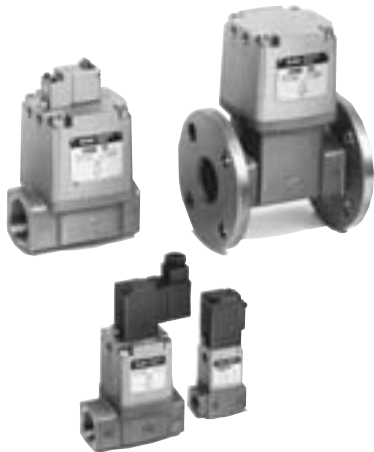

Model

Refer to Best Pneumatics No. 7 for details.

Model	Port size	Orifice dia ø [mm]	Flow characteristics				Mass [kg]	
			Measured by air		Measured by water		Air operated	External pilot solenoid
			C[dm ³ /(bar·sec)]	b	Cv	Av x 10 ⁻⁶ m ²		
VNB2□4□-10A	3/8	11	9.6	0.40	2.6	71	0.6	0.7
VNB2□□□-10A		15	17	0.32	4.0			
VNB2□4□-15A		1/2	11	9.6	0.40			
VNB2□□□-15A	15		19	0.24	4.8			
VNB3□4□-20A	3/4	14	18	0.42	5.4	140	0.9	1.0
VNB3□□□-20A		20	35	0.13	7.4			

Model	Port size		Orifice dia ø [mm]	Flow characteristics		Mass [kg]	
	Screw-in	Flange		Cv	Effective area (mm ²)	Air operated	External pilot solenoid
VNB4□4□-25A	1	—	16	7	130	1.4	1.5
VNB4□□□-25A			25	12	220		
VNB5□4□-32A	1 1/4	—	22	11	210	2.5	2.6
VNB5□□□-32A			32	18	320		
VNB5□4□-32F	—	32	22	11	210	5.7	5.8
VNB5□□□-32F			32	18	320		
VNB6□4□-40A	1 1/2	—	28	19	330	4.1	4.2
VNB6□□□-40A			40	28	500		
VNB6□4□-40F	—	40	28	19	330	7.7	7.8
VNB6□□□-40F			40	28	500		
VNB7□4□-50A	2	—	33	29	520	6.3	6.4
VNB7□□□-50A			50	43	770		
VNB7□4□-50F	—	50	33	29	520	11.4	11.5
VNB7□□□-50F			50	43	770		

Directional Control Valve/Solenoid Valve/Vacuum System Peripherals

3 position valve VEX3



Air operated type

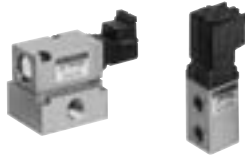

Internal/External pilot solenoid type

Vacuum suction and release

The 3 port, 3 position double solenoid that permits vacuum suction, release, and suspension (closed) is ideal for a system where many valves are used for a single circuit.

Specifications

Refer to Best Pneumatics No. 1 for details.

Model	Body ported	VEX312□-01-02	VEX332□-02-03 04	VEX350□-04-06 10	VEX370□-10-12	VEX390□-14-20
	Base mounted	VEX322□-01-02	VEX342□-02-03 04	—	—	—
Operation		Air operated, External pilot solenoid, Internal pilot solenoid				
Fluid		Air				
Proof pressure		1.5 MPa				
Operating pressure range	Air operated	Low vacuum Vac. to 1.0 MPa				
		External pilot pressure 0.2 to 1.0 MPa				
	External pilot solenoid	Low vacuum Vac. to 1.0 MPa				
		External pilot pressure 0.2 to 0.7MPa	External pilot pressure 0.2 to 0.9 MPa			
Internal pilot solenoid	0.2 to 0.7MPa	0.2 to 0.9 MPa				

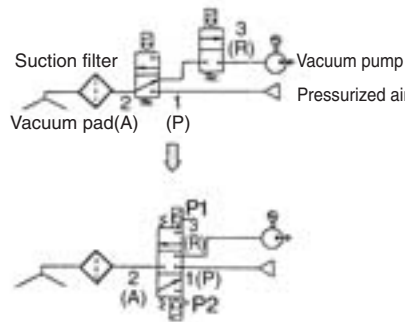

- Sequential switching operation prevents the inflow of pressurized air into the vacuum pump system.

⚠ Caution

- To maintain the vacuum of port A via the closed center, be aware that the vacuum could be decreased due to leakage from the vacuum pad and the piping.

Vacuum/release unit VQD1000-V



- **Response speed**
13 msec (at 500 mm^{*})/
18.5 msec (at 1000 mm^{*})
* Distance from a unit to a workpiece
(Piping I.D. ø2.5)
- **Smooth removal of workpiece without overshoot**
No blow off of workpiece by release air
- **No need to adjust the timing for switch-over vacuum and positive pressure.**
(Single signal control)
- **No need to set a restriction circuit for release air**

Specifications

Refer to Best Pneumatics No. 1 for details.

Valve construction		Direct operated poppet
Fluid		Air, Inert gas/Compatible with low ozone
Operating pressure range	Suction (Negative pressure)	0 to -100 kPa
	Release (Positive pressure)	0 to 0.7 MPa
Response time	Suction (OFF)	2 ± 1 msec
	Release (ON)	4 ± 1 msec

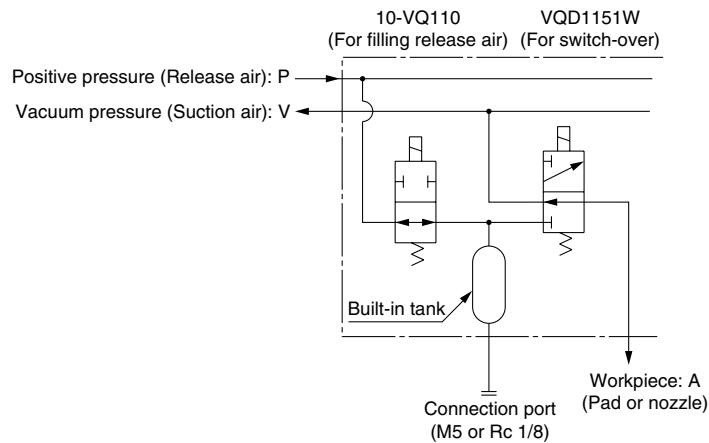

ZA
ZX
ZR
ZM
ZMA
ZQ
ZH
ZU
ZL
ZY□
ZF□
ZP□
SP
ZCUK
AMJ
AMV
AEP
HEP

Related Equipment

Directional Control Valve/Solenoid Valve Vacuum System Peripherals

Vacuum release valve with throttle valve SJ3A6

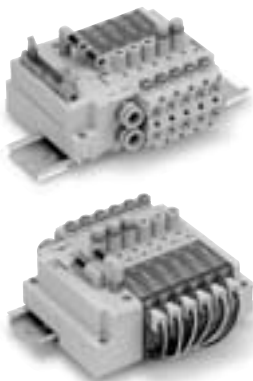

2 spool valves included.
Possible to control vacuum adsorption and release by a valve.

- Current consumption 0.15 W (With energy saving circuit)
 - Width 10 mm (Same as Series SJ3000)
 - With throttle valve that can control the flow rate of release air
 - Replaceable filters are built in the vacuum side and release side respectively
 - With a pressure detection port that enables users to connect a pressure switch, etc.
 - Can be mounted with a 4 port solenoid valve SJ2000/3000 (Made to Order).
(Please contact SMC for details.)
 - Possible to switch pressure of two wiring systems by applying different positive pressures to 1 (P) port and 3/5 (E).
- (In this case, flow rate is adjustable only at the P port side.)

Specifications

Refer to Best Pneumatics No. 1 for details.

Valve construction		3 position, 3 port valve with throttle valve
Fluid		Air
Operating pressure range Mpa	Release pressure port 1 (P)	0.25 to 0.7
	Vacuum pressure port 3/5 (E)	-100 kPa to 0.7 ⁽¹⁾
	Pilot X port	0.25 to 0.7 ⁽²⁾

Note 1) Can be used with positive pressure depending on applications.

Note 2) Pressure of the pilot X port must be the same as that of the release port 1 (P) or more.

Adsorption Transfer System Circuit Example

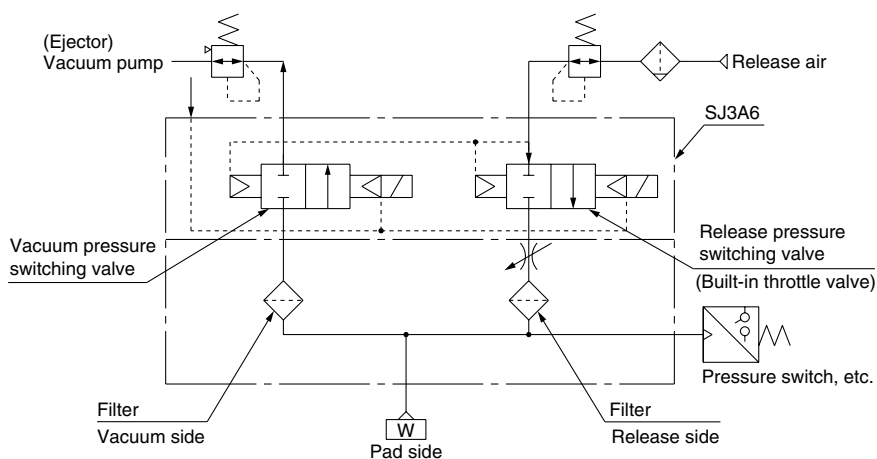

Vacuum System Peripherals: Vacuum Pressure Switch

Refer to Best Pneumatics No. 6 for details.



● 2-Color Display High Precision Digital Pressure Switch: ZSE30

Model	ZSE30	
Rated pressure range	-100.0 to 100.0 kPa	
Set pressure range	-101.0 to 101.0 kPa	
Proof pressure	500 kPa	
Setting/Display resolution	0.2 kPa	
Fluid	Air/Non-corrosive gas/Non-flammable gas	
Power supply voltage	12 to 24 VDC $\pm 10\%$, Ripple (p-p) 10% or less (With power supply polarity protection)	
Current consumption	45 mA or less (No load)	
Switch output	NPN or PNP open collector output: 1 output	
Max. load current	80 mA	
Max. applied voltage	30 V (With NPN output)	
Residual voltage	1 V or less (With load current of 80 mA)	
Response time	2.5 ms or less (Response time selections with anti-chattering function: 20 ms, 160 ms, 640 ms, 1280 ms)	
Short circuit protection	With short circuit protection	



● High-Precision Digital Pressure Switch: ZSE40

Model	ZSE40	
Rated pressure range	0.0 to -101.3 kPa	
Operating pressure range/Set pressure range	10.0 to -101.3 kPa	
Proof pressure	500 kPa	
Set pressure resolution kPa	0.1	
Applicable fluid	Air/Non-corrosive gas/Non-flammable gas	
Power supply voltage	12 to 24 VDC $\pm 10\%$, Ripple (p-p) 10% or less (With power supply polarity protection)	
Current consumption	55 mA or less	
Switch output	NPN or PNP open collector output: 2 outputs	
Max. load current	80 mA	
Max. applied voltage	30 V (With NPN output)	
Residual voltage	1 V or less (With load current of 80 mA)	
Response time	2.5 ms or less (Response time selections with anti-chattering function: 24 ms, 192 ms, 768 ms)	
Short circuit protection	With short circuit protection	



● 2-Color Display Digital Pressure Switch for General Fluids: ZSE80

Model	ZSE80 (Vacuum pressure)	
Rated pressure range	0.0 to -101.0 kPa	
Set pressure range	10.0 to -111.0 kPa	
Proof pressure	500 kPa	
Applicable fluid	Fluid that will not corrode stainless steel 630 and 304	
Power supply voltage	12 to 24 VDC $\pm 10\%$, Ripple (p-p) 10% or less (With power supply polarity protection)	
Current consumption	45 mA or less	
Switch output	NPN 1 output, NPN 2 outputs, PNP 1 output, PNP 2 outputs	
Max. load current	80 mA	
Max. applied voltage	28 V (With NPN output)	
Residual voltage	1 V or less (With load current of 80 mA)	
Response time	2.5 ms or less (Response time selections with anti-chattering function: 20 ms, 100 ms, 500 ms, 1000 ms, 2000 ms)	
Short circuit protection	With short circuit protection	



● High-Precision Digital Pressure Switch for General Fluids: ZSE50F

Model	ZSE50F	
Rated pressure range	-100.0 to 100.0 kPa	
Set pressure range	-100.0 to 100.0 kPa	
Proof pressure	500 kPa	
Set pressure resolution	0.1 kPa	
Applicable fluid	Fluid that will not corrode stainless steel 630 and 304	
Power supply voltage	12 to 24 VDC $\pm 10\%$, Ripple (p-p) 10% or less (With power supply polarity protection)	
Current consumption	55 mA or less	
Switch output	NPN or PNP open collector output: 2 output	
Max. load current	80 mA	
Max. applied voltage	30 V (With NPN output)	
Residual voltage	1 V or less (With load current of 80 mA)	
Response time	2.5 ms or less (Response time selections with anti-chattering function: 24 ms, 192 ms, 768 ms)	
Short circuit protection	With short circuit protection	

ZA
ZX
ZR
ZM
ZMA
ZQ
ZH
ZU
ZL
ZY□
ZF□
ZP□
SP
ZCUK
AMJ
AMV
AEP
HEP
Related Equipment

Vacuum Pressure Switch/Vacuum System Peripherals

Refer to Best Pneumatics No. 6 for details.



● High-Precision Digital Pressure Switch for General Fluids: ZSE60F

Model	ZSE60F (Compound pressure)
Rated pressure range	-100.0 to 100.0 kPa
Set pressure range	-100.0 to 100.0 kPa
Proof pressure	500 kPa
Set pressure resolution	0.1 kPa
Applicable fluid	Fluid that will not corrode stainless steel 630 and 304
Power supply voltage	12 to 24 VDC ±10%, Ripple (p-p) 10% or less (With power supply polarity protection)
Current consumption	55 mA or less
Switch output	NPN or PNP open collector output (2 outputs)
Max. load current	80 mA
Max. applied voltage	30 V (With NPN output)
Residual voltage	1 V or less (With load current of 80 mA)
Response time	2.5 ms or less (Response time selections with anti-chattering function: 24 ms, 192 ms, 768 ms)
Short circuit protection	With short circuit protection



● LCD Readout Digital Pressure Switch: ZSE3

Model	ZSE3
Pressure setting range	0 to -101 kPa
Maximum operating pressure	200 kPa
Min. display unit	1 kPa
Applicable fluid	Air/Non-corrosive gas/Non-flammable gas
Power supply voltage	12 to 24 VDC ±10%, Ripple (p-p) 10% or less (With power supply polarity protection)
Current consumption	25 mA or less



● Compact Pressure Switch: ZSE1

Model	ZSE1
Pressure setting range	0 to -101 kPa
Proof pressure	500 kPa
Temperature characteristics	±3% F.S. or less
Power supply voltage	12 to 24 VDC ±10%, Ripple (p-p) 10% or less (With power supply polarity protection)
Current consumption	17 mA or less at 24 VDC, 2 output: 25 mA or less at 24 VDC
Port size	01: R 1/8, M5 x 0.8, T1: NPTF 1/8, M5 x 0.8, 00: ZM ejector mounted style
Operating temperature range	0 to 60°C (No condensation or freezing)



● Compact Pressure Switch: ZSE2

Model	ZSE2
Pressure setting range	0 to -101 kPa
Proof pressure	500 kPa
Operating voltage	12 to 24 VDC ±10%, Ripple (p-p) 10% or less (With power supply polarity protection)
Operation indicator light	Lights up when ON (Red)
Current consumption	17 mA or less (When 24 VDC is ON)
Operating temperature range	0 to 60°C (No condensation or freezing)
Port size	01: R 1/8, M5 x 0.8, T1: NPTF 1/8, M5 x 0.8 0X: With suction filter (For mounting on ZM unit) 0R: Base mounted style (For mounting on ZR unit)

Vacuum Pressure Switch/Vacuum System Peripherals

Refer to Best Pneumatics No. 6 for details.

● Air Checker Electronic Pressure Switch: PS1100



Model	PS1100-R06L
Switch output	Present prss. ≤ Setting prss.: ON
Max. operating pressure	1 MPa
Set pressure range	-0.1 to 0.4 MPa
Applicable fluid	Air/Non-corrosive gas/Non-flammable gas
Operation indicator light	ON: When red LED turns on
Temperature characteristics	±3% F.S. or less
Repeatability	±1% F.S. or less
Hysteresis	4% F.S.
Load voltage	12 to 24 VDC ±10%, Ripple (p-p) 10% or less
Load current	5 to 40 mA
Leakage	1 mA or less
Internal voltage drop	5 V or less
Operating temperature range	0 to 60°C (No condensation)

● Adsorption Confirmation Switch: ZSP1

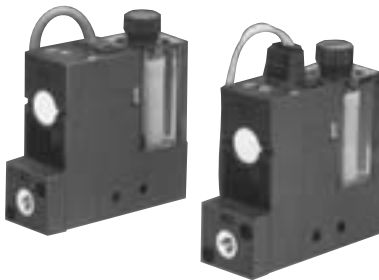

Model	ZSP1-S	ZSP1-B
Applicable fluid	Air	
Rated pressure range	-20 to -101 kPa	
Applicable adsorption nozzle dia.	ø0.3 to ø0.7	ø0.5 to ø1.2
Hysteresis	0.5 kPa	
Internal orifice	ø0.5	ø0.8
Power supply voltage	12 to 24 VDC ±10%, Ripple (p-p) 10% or less (With power supply polarity protection)	
Switch output	NPN Open collector 30 V, 80 mA	

● Multi-channel Controller: Series PSE200



Model	PSE200	PSE201
Switch output	NPN open collector	PNP open collector
Power supply voltage	12 to 24 VDC ±10%, Ripple (p-p) 10% or less (With power supply polarity protection)	
Current consumption	55 mA or less (Current consumption for sensor is not included.)	
Power supply voltage for sensor	[Power supply voltage] - 1.5 V	
Power supply current for sensor	40 mA maximum (100 mA maximum for the total power supply current when 4 sensors are input.)	

● Pressure Sensor Controller: PSE300



Model	PSE300□					
Set pressure (differential pressure) range	-101 to 101 kPa	10 to -101 kPa	-10 to 100 kPa	-0.1 to 1 MPa	-50 to 500 kPa	-0.2 to 2 kPa
Pressure range	For compound pressure	For vacuum	For low pressure	For positive pressure		For slight differential pressure
Rated pressure (differential pressure) range	-100 to 100 kPa	0 to -101 kPa	0 to 100 kPa	0 to 1 MPa	0 to 500 kPa	0 to 2 kPa
Power supply voltage	12 to 24 VDC ±10%, Ripple (p-p) 10% or less (With power supply polarity protection)					
Current consumption	50 mA or less (Current consumption for sensor is not included.)					

● Pressure Sensor: PSE530



Model	PSE531-M5
Rated pressure range	0 to -101 kPa
Proof pressure	500 kPa
Applicable fluid	Air/Non-corrosive gas/Non-flammable gas
Power supply voltage	12 to 24 VDC ±10%, Ripple (p-p) 10% or less (With power supply polarity protection)
Current consumption	15 mA or less
Output specifications	Analog output (1 to 5 V, Output impedance: Approx. 1 kΩ)

ZA
ZX
ZR
ZM
ZMA
ZQ
ZH
ZU
ZL
ZY□
ZF□
ZP□
SP
ZCUK
AMJ
AMV
AEP
HEP

Related Equipment

Vacuum Pressure Switch/Vacuum System Peripherals

Refer to Best Pneumatics No. 6 for details.

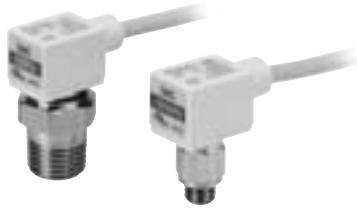

● Compact Pneumatic Pressure Switch: PSE540

Model	PSE541	PSE543
Rated pressure range	0 to -101 kPa	-100 to 100 kPa
Proof pressure	500 kPa	
Applicable fluid	Air/Non-corrosive gas/Non-flammable gas	
Power supply voltage	12 to 24 VDC ±10%, Ripple (p-p) 10% or less (With power supply polarity protection)	
Current consumption	15 mA or less	
Output specifications	Analog output (1 to 5 V, Output impedance: Approx. 1 kΩ)	

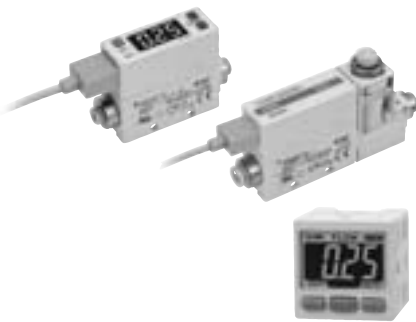

● 2-Color Display Digital Flow Switch: PFM

Model	Integrated type	PFM710	PFM725	PFM750	PFM711
	Separate sensor unit	PFM510	PFM525	PFM550	PFM511
	Separate monitor unit	PFM3□□			
Applicable fluid	Dry air, N ₂ , Ar, CO ₂ (Air quality degrees: JIS B8392.1-1. 1.2 to 1.6.2, ISO8573.1-1. 1.2 to 1.6.2)				
Rated flow rate range (Flow rate range)	Dry air, N ₂ , Ar	0.2 to 10 l/min	0.5 to 25 l/min	1 to 50 l/min	2 to 100 l/min
	CO ₂	0.2 to 5 l/min	0.5 to 12.5 l/min	1 to 25 l/min	2 to 50 l/min

● Flow Sensor: PFMV

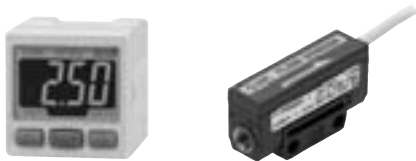

Series	Set flow rate range (l/min)
PFMV	0 to 0.5
	0 to 1
	0 to 3
	-0.5 to 0.5
	-1 to 1
	-3 to 3
Features	<ul style="list-style-type: none"> ● Adsorption confirmation of tiny workpiece ● Repeatability ±2% F.S. or less ● Response speed 5 ms or less, Withstand pressure 500 kPa ● Grease-free, RoHS-compliant ● Compatible with all flow rates with a voltage monitor

Vacuum System Peripherals: Pressure Gauge for Vacuum: Series GZ46



GZ46

GZ46-2

Specifications

Model		GZ46	GZ46E
Type		Back screw	
Connecting ⁽¹⁾		R 1/8 R 1/4 (Option: M = with M5 x thread)	
Fluid ⁽²⁾		Air	
Indication accuracy		±3% F.S. (Full span)	
Parts washing		—	Wetted parts degrease washing
Material	Case (Surface treatment)	Rolled steel (Black melamine coating)	
	Clear cover (Surface treatment)	Polycarbonate Part no: G46-00-00-3	Polycarbonate (Hard coated) Part no: G46-00-00-2
	Body	Brass	Brass (Electroless nickel plated) ⁽³⁾
	Bourdon tube	Brass	
With attachment cover assembly	C	Part no: 1305104-1A	
	C1	Part no: 1305104-3A	

Note 1) When attaching the pressure gauge, make sure not to fasten excessively, since it could cause the gauge to leak or to become damaged.

Use port tape as sealant. Recommended fastening torque = R 1/8: 7 to 9 N·m, R 1/4: 12 to 14 N·m.

Note 2) Please consult with SMC if other fluids are used, a corrosive problem may result.

Note 3) Mobile parts (gear, etc) inside the pressure gauge is made of brass.

Selection

⚠ Caution

- Do not expose the gauge to shocks or vibrations.
- Please contact SMC if the gauge is exposed to pressure pulsations or high frequency operation.

Mounting

⚠ Caution

- During transport and installation, make sure the gauge is not exposed to shock, such as dropping, to maintain precision.
- To ensure the proper posture of the gauge, the zero point of the graduation on the gauge must face downward and perpendicular to the ground.
- Do not install the gauge in an area that is exposed to high temperatures or humidity.
- When attaching the pressure gauge, make sure to place a wrench directly on the squared off portion. If a force is applied to some other area to screw in the gauge, it could cause the gauge to leak or to become damaged.

How to Order

GZ 46 E - K 1 K - 01 M - C

Pressure gauge for vacuum

Model

Symbol	O.D.
46	ø42.5

Specifications

Symbol	Specifications
Nil	—
E	External parts oil-free Copper/Fluorine-free

Pressure unit for positive pressure

Symbol	Unit
Nil	—
K	kPa

Display pressure range

Symbol	Unit: kPa
Nil	-100 to 0
1	-100 to 100
2	-100 to 200

Pressure unit for vacuum

Symbol	Unit
K	kPa

Connecting

Symbol	Size
01	R 1/8
02	R 1/4

Option

Symbol	Specifications
Nil	—
M	M5 (Female thread)

Note) Use M5 female thread for panel mounting.

Attachment (Covering assembly)

Symbol	Specifications
Nil	Without covering assembly
C	Clear cover has no protrusion (Clear cover is irremovable.)
C1	Clear cover has no protrusion (Clear cover is removable.)

Note) X3 (wetted parts) is not stainless steel specifications.

Model (Stock item)

Model	Pressure range ^{Note)}	Unit	Connecting	Note
	kPa			
GZ46-K-01 to 02	-100 to 0	kPa	R 1/8, 1/4	—
GZ46-K-01 to 02-C, C1	-100 to 0	kPa	R 1/8, 1/4	With covering assembly
GZ46-K-01 to 02M	-100 to 0	kPa	R 1/8, 1/4 M5 (Female thread)	—
GZ46E-K-01 to 02M	-100 to 0	kPa	R 1/8, 1/4 M5 (Female thread)	—
GZ46-K2K-01 to 02	-100 to 200	kPa	R 1/8, 1/4	—

Note) Do not apply pressure that exceeds max. display pressure, since it would cause the gauge to malfunction.

Model (Made to order) Other versions (not including models below) can be made on a made-to-order basis. Please consult with SMC for details, as delivery times may be extended.

Model	Pressure range ^{Note)}	Unit	Connecting	Note
	kPa			
GZ46-K1K-01 to 02	-100 to 100	kPa	R 1/8, 1/4	—

Note) Do not apply pressure that exceeds max. display pressure, since it would cause the gauge to malfunction.

Dimensions

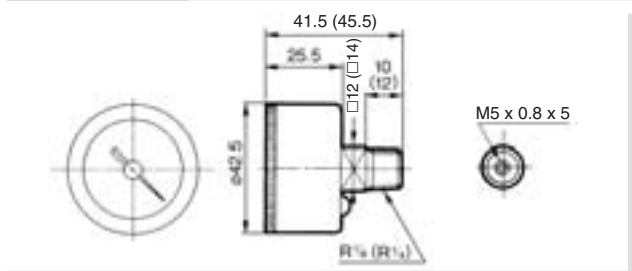

How to install cover assembly

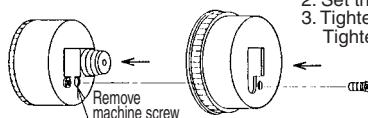

- Remove machine screw (1 location) of pressure gauge.
- Set the cover on pressure gauge.
- Tighten the machine screw to cover. Tightening torque is 0.3 to 0.5 N·m.

With cover assembly (For panel mounting)

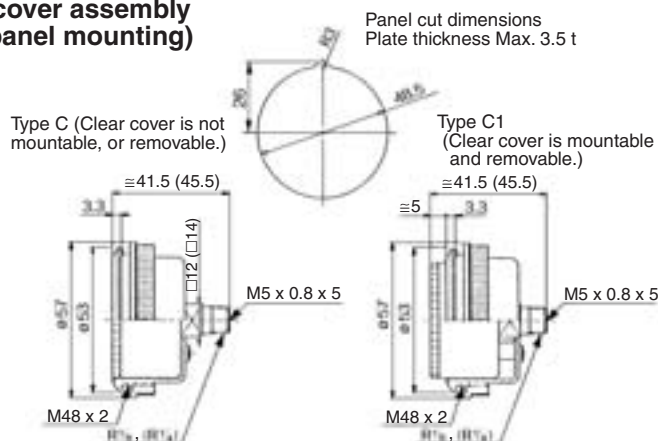

(): Port size is R 1/4

Vacuum System Peripherals: Flow Control Equipment

Refer to Best Pneumatics No. 6 for details.

Speed controller

AS

Possible to control vacuum release air

With one-touch fitting

The tubing can be removed and installed through One-touch operation. The body can be screwed in directly to the equipment that you are using. As a result, the piping labor can be dramatically reduced.



Elbow type

Model		Port size Rc	Applicable tubing O.D. (mm)				
Elbow type	Universal type		3.2	4	6	10	12
AS1201F-M5-□□-X214	AS1301F-M5-□□-X214	M5 x 0.8	●	●	●	—	—
AS2201F-01-□□S-X214	AS2301F-01-□□S-X214	1/8	●	●	●	●	—
AS2201F-02-□□S-X214	AS2301F-02-□□S-X214	1/4	—	●	●	●	—
AS3201F-03-□□S-X214	AS3301F-03-□□S-X214	3/8	—	—	●	●	●
AS4201F-04-□□S-X214	AS4301F-04-□□S-X214	1/2	—	—	—	●	●

*Dimensions: Same dimensions as mentioned in pages 420 and 421 of Best Pneumatics No. 6.

*Flow rate: Same as controlled flow of the standard product.

Check valve

AK

Large valve capacity
Low cracking pressure/0.02 MPa



Series AK

Model	Port size Rc	Effective area (mm ²)
AK2000	1/8, 1/4	27.5 (Rc 1/4)
AK4000	1/4, 3/8, 1/2	95 (Rc 1/2)
AK6000	3/4, 1	230 (Rc 1)

Check valve with One-touch fitting

Straight type: AKH

Easily installed in pipe lines.

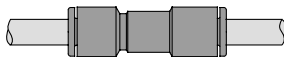

Metric size

Model	Applicable tubing O.D.	Effective area (mm ²)	
AKH	04-00	ø4	2.8
	06-00	ø6	6.5
	08-00	ø8	14
	10-00	ø10	24
	12-00	ø12	34

Inch size

Model	Applicable tubing O.D.	Effective area (mm ²)	
AKH	03-00	5/32	2.8
	07-00	1/4	6.5
	09-00	5/16	14
	11-00	3/8	24
	13-00	1/2	34

Check valve with One-touch fitting

Male connector type: AKH

Can be used directly on equipment.

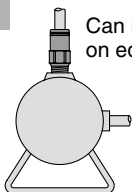

Metric size

Model	Applicable tubing O.D.	Port size R					Effective area (mm ²)
		M5	1/8	1/4	3/8	1/2	
AKH	04□	ø4	●	●			2.8
	06□	ø6	●	●	●		6.5 (R 1/8)
	08□	ø8		●	●	●	14 (R 1/4)
	10□	ø10			●	●	24
	12□	ø12				●	34

Inch size

Model	Applicable tubing O.D.	Port size NPT					Effective area (mm ²)
		10-32 UNF	1/8	1/4	3/8	1/2	
AKH	03□	ø5/32	●	●			2.8
	07□	ø1/4	●	●	●		6.5 (NPT 1/8)
	09□	ø5/16		●	●	●	14 (NPT 1/4)
	11□	ø3/8			●	●	24
	13□	ø1/2				●	34

Check valve

Bushing type: AKB

Can be used in applications with splashing coolant and spatter, etc.

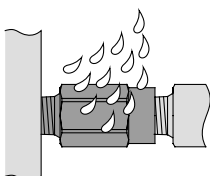

R thread

Model	Female thread Rc	Male thread R				Effective area (mm ²)
		1/8	1/4	3/8	1/2	
AKB	01□	1/8	●			6.5
	02□	1/4		●		14
	03□	3/8			●	24
	04□	1/2				●

NPT thread

Model	Female thread NPT	Male thread NPT				Effective area (mm ²)
		1/8	1/4	3/8	1/2	
AKB	01□	1/8	●			6.5
	02□	1/4		●		14
	03□	3/8			●	24
	04□	1/2				●

Vacuum System Peripherals: Made to Order



1 Vacuum Release Valve with Throttle Valve: SY5A2R

- Line for vacuum adsorption transfer
- Built-in throttle valve in the vacuum release valve
- Can be mounted on the SS5Y5-20P-type (Flat ribbon cable type) Manifold
- Valve effective area

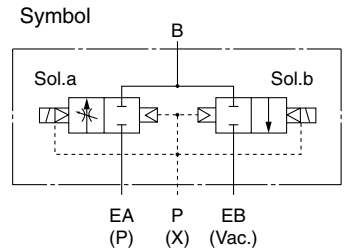

B port Port size ^{Note 1)}	Effective area: mm ²	
	EA→B ^{Note 2)}	B→EB
C6	4.4	6.8
C8	4.5	7.0

Note 1) Refer to the part numbers for the port size.
Note 2) When the built-in throttle valve is fully open.

Specifications

Valve type	External pilot type, Dual 2 port solenoid valve	
Type of actuation	Normally closed (N.C. valve)	
Fluid	Air	
Operating pressure range	P (External pilot pressure)	0.15 to 0.7 MPa
	EA (Vacuum release pressure)	0 to 0.7 MPa
	EB (Vacuum)	-100 kPa to 0 MPa
Ambient and fluid temperature	-10 to 50°C (No condensation)	

Effective Area/Mass

B port Port size ^{Note 1)}	Effective area: mm ²		Mass (g)
	EA→B ^{Note 2)}	B→EB	
C6	4.4	6.8	94
C8	4.5	7.0	88

Note 1) Refer to the part numbers for the port size.
Note 2) When the built-in throttle valve is fully open.

How to Order

Single unit: External pilot type dual 2 port solenoid valve

SY5A2R - 5 L [] [] - C6 - []

- Rated voltage ^{Note 3)}
- Electrical entry ^{Note 3)}
- Light/surge voltage suppressor ^{Note 3)}
- Manual override ^{Note 3)}
- Bracket**

Nil	Without bracket
F2	With bracket (F2)

 Bracket part no.: SX5000-16-8A
- B-port port size**

C6	ø6 One-touch fitting
C8	ø8 One-touch fitting

Note 3) Refer to the Series SY5000 catalog.

Manifold: Body ported bar stock flat ribbon cable type (20P type)

SS5Y5 - 20P - 08 - X688

• **Stations** ^{Note 4)}

03	3 stations
⋮	⋮
12	12 stations

Note 4) This manifold part number specifies that a valve (part no.: SY5A2R-5LOZ-C6-X10) and connector assembly (part no.: SY3000-37-4A) are assembled depending on the number of stations and shipped. When other valves are used, please consult SMC for details.

- ZA
- ZX
- ZR
- ZM
- ZMA
- ZQ
- ZH
- ZU
- ZL
- ZY□
- ZF□
- ZP□
- SP
- ZCUK
- AMJ
- AMV
- AEP
- HEP

Related Equipment

Dimensions/SS5Y5-20P-08-X688

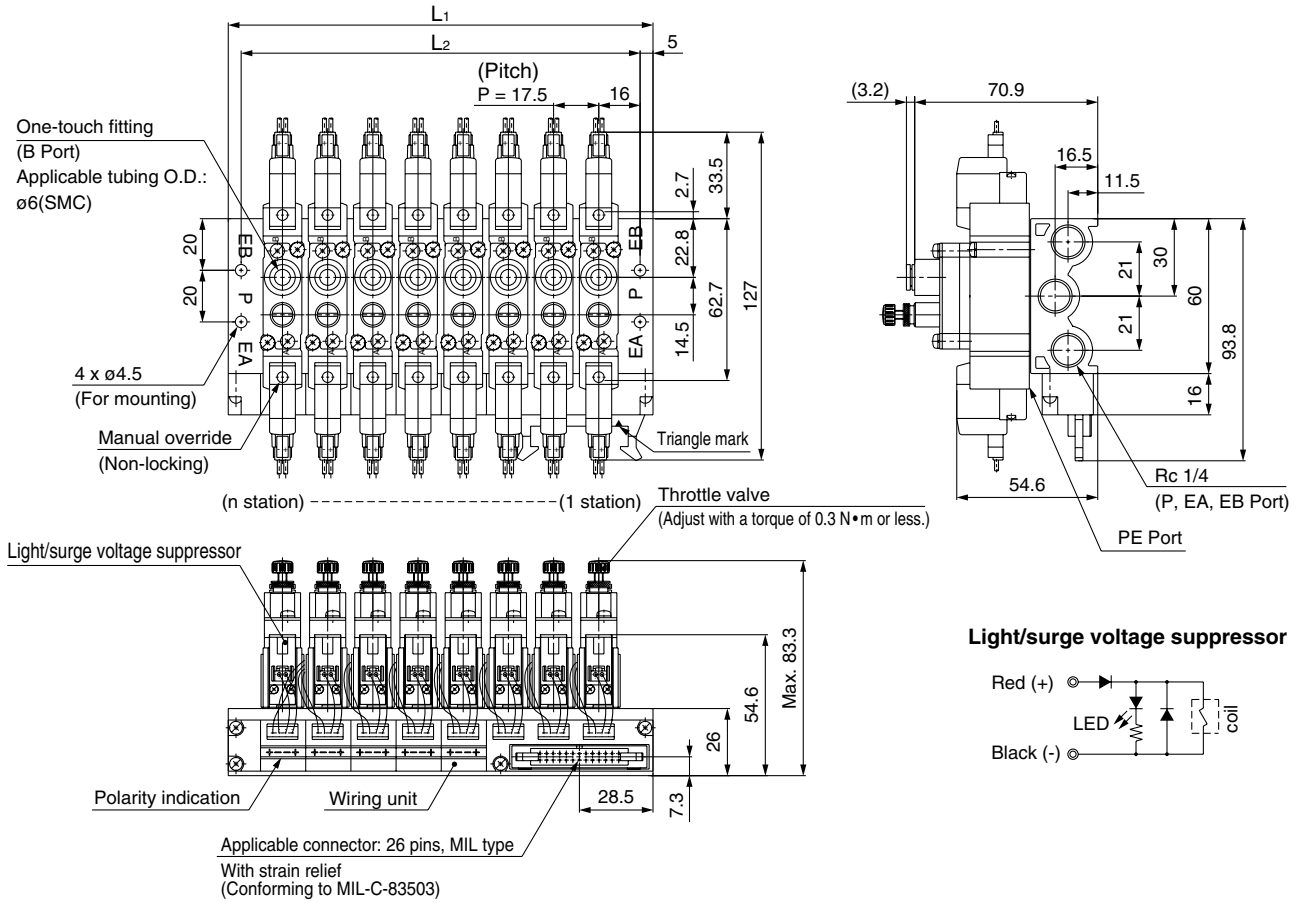

Pneumatic Circuit

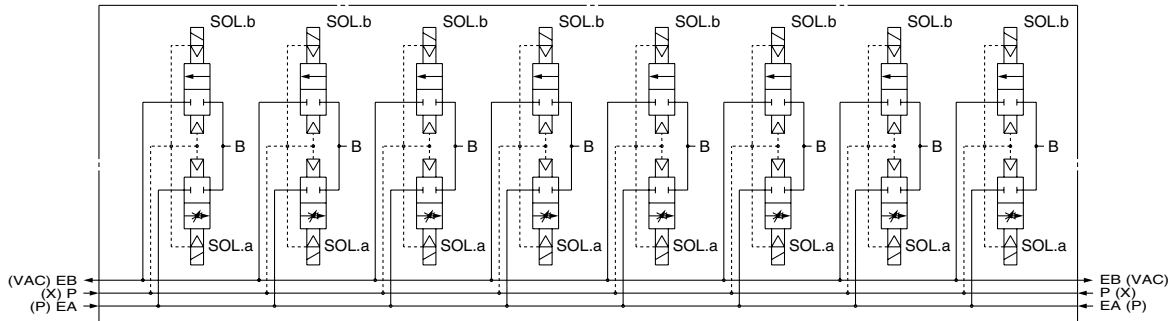

Schematic of Connector (Example: For this figure) (Light/surge voltage suppressor is not included.)

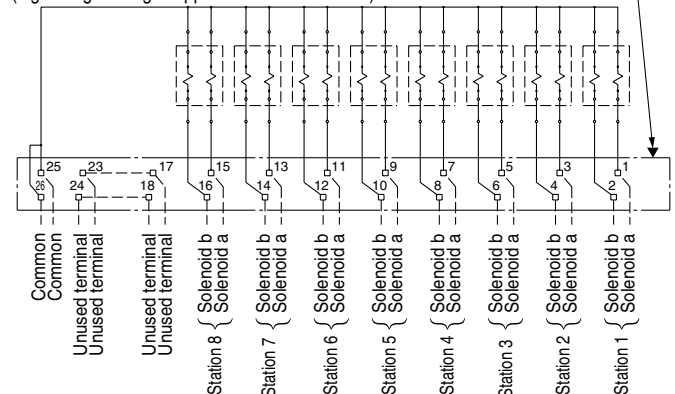

L: Dimensions: mm

L	n	n: Stations									
		3	4	5	6	7	8	9	10	11	12
L ₁		77	94.5	112	129.5	147	164.5	182	199.5	217	234.5
L ₂		67	84.5	102	119.5	137	154.5	172	189.5	207	224.5
\square		03	04	05	06	07	08	09	10	11	12

* Dimensions are for SS5Y5-20P-08-X688.

* Applicable blanking plate assembly part no.: SY5000-26-21A (with screws, gaskets and dust cap)

* The product cannot be mounted with standard products Series SY5000/500 on a manifold.



Series SS5Y5-20P-□-X688 Specific Product Precautions

Be sure to read before handling.
Refer to front matters 38 and 39 for Safety Instructions.

How to Use Manifold

⚠ Caution

1. For more than 10 stations, both poles of the common should be wired.
2. When replacing a solenoid valve, etc., be sure to mount it by placing the solenoid a side on the connector (MIL type) side.
3. Terminal no. is not indicated on the connector.
4. The terminal no. indicated in the connection schematic of connector, as shown in the reference, means a correlation of 1, 2, 3...26 from the triangle mark side on the flat ribbon cable of connector.
(Refer to the reference drawing.)

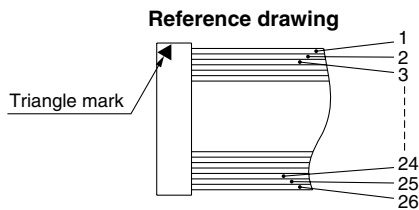

5. If a large amount of drainage is included in the supply air, it may cause electrical trouble since a wiring unit is located in the place where exhaust from the PE port directly goes through. Be sure to control the supply air.
6. A piping port is different from that for the standard product. When not connected properly, the product will not operate properly.

[P port: External pilot port, EA port: Vacuum release pressure port, EB port: Vacuum suction port]

Part number SS5Y5-20P-□□-X688 is assembled with a solenoid valve, etc.

2 Vacuum Release Valve with Throttle Valve: SV1A4R-X8

- For vacuum adsorption transfer
- With a throttle valve that can control the flow rate of release air (Slotted type is used to ensure safety.)
- Possible to block release air and vacuum at the same time (3 position function)
- Compatible with manifold Series SV1000

Symbol

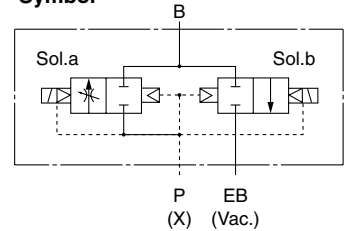

Specifications

Common specifications

Type of actuation	Internal pilot type 3 position, 3 port solenoid valve	
Valve type	Normally closed (N.C.)	
Fluid	Air	
Operating pressure range	P (Vacuum release pressure)	0.15 to 0.7 MPa
	EB (Vacuum pressure)	-100 kPa to 0 MPa (Atmospheric pressure)
Ambient and fluid temperature	-10 to 50°C	
Allowable voltage fluctuation	-10 to +10%	
Electrical entry	Plug-in type	
Mass	73 g	

Note) Specifications other than the above are the same as Series SV1000

How to Order

Refer to How to Order Series SV1000 (Standard).

SV1A4R- F -X8

Rated voltage Manual override

Light/surge voltage suppressor

Note) Please contact SMC when the product is mounted with a standard 5 port solenoid valve on a manifold.

Dimensions

Dimensions other than the throttle valve for vacuum release are the same as the standard product (SV1000).

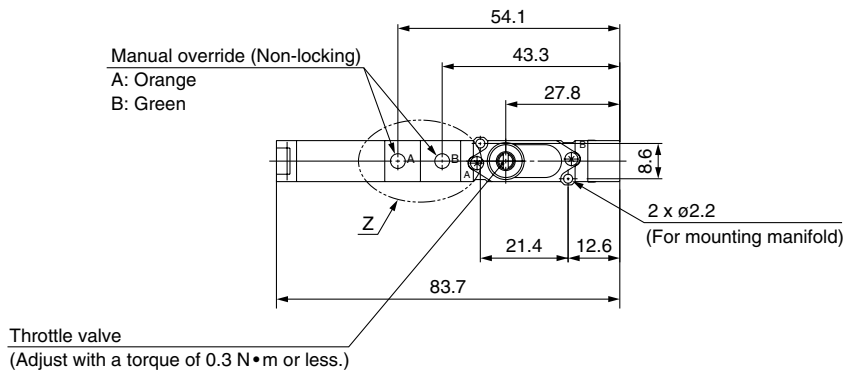

Note) Use the manifold that the product is mounted on after mounting a plug to the A port.

⚠ For safe operation, be sure to read the Safety Instructions on front matters 38 and 39 before handling.

ZA
ZX
ZR
ZM
ZMA
ZQ
ZH
ZU
ZL
ZY□
ZF□
ZP□
SP
ZCUK
AMJ
AMV
AEP
HEP

Related Equipment

Made to Order/Vacuum System Peripherals

3 Air Suction Filter (Filter volume: 1 cm³)/FGZG220A-B□□□

• Used to shorten the response time of vacuum adsorption

Shorten the arrival time of vacuum pressure when adsorbing the workpiece by reducing the volume of the filter used for the vacuum adsorption system. This product is mainly used for the semiconductor manufacturing equipment handler (Reducing the cycle time of the equipment).

• Volume of air suction filter: 1 cm³

Application Example

When the standard air suction filter (ZFB) volume is 5 cm³, the volume is reduced to 4 cm³ by using this filter (volume: 1 cm³). This volume (4 cm³) is equivalent to ø4 mm tubing (I.D. 2.5 mm) and length of approx. 800 mm.

Specifications

Fluid	Air, Nitrogen
Operating pressure	Negative pressure
Withstand pressure	0.5 MPa
Ambient and fluid temperature	0 to 60°C (No freezing)
Nominal filtration	010: 10 μm, 020: 20 μm 040: 40 μm, 070: 70 μm
Element differential pressure resistance	0.15 MPa

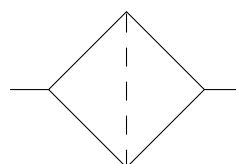

JIS Symbol

How to Order

Air Suction Filter

FGZG220A - B 010

Element with Cylindrical Base
(Replacement element part no.)

EBW - 7 - 8 - 1.5 - 010

• Nominal filtration

010	10 μm
020	20 μm
040	40 μm
070	70 μm

Note 1) Replace the filter element when the pressure drops approximately 0.02 MPa.

Note 2) During disassembly and assembly, confirm that there are no scratches or damage, etc. on the O-ring.

Note 3) When disassembling, a wrench (nominal size 8) is required. Please consult with SMC for information not specified such as how to replace (disassemble) elements, etc.

Dimensions

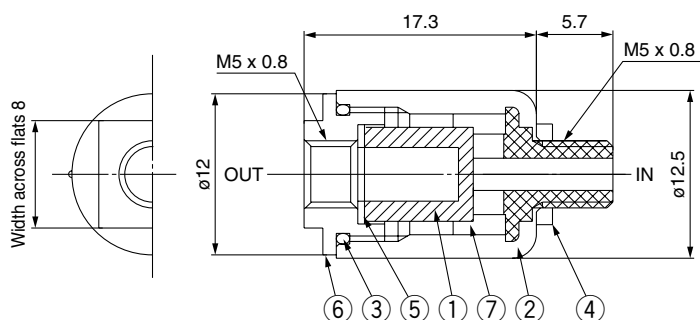

Description

No.	Description	Material
1	Element with cylindrical base	BC
2	Case	Transparent nylon
3	O-ring	NBR
4	Seal	Nylon
5	Seal	NBR
6	Cover	A2017
7	Element guide	PTFE

Note 1) Verify the directions for IN and OUT that are indicated on the body to ensure a proper connection.

It is not possible to ensure the sealing performance of the filter element if connections are reversed.

Note 2) When an element becomes clogged, stop operation, change the inside pressure to atmospheric pressure, and then replace the element (element with cylindrical base).

Note 3) Do not use in a line where a pressurized condition is maintained since the body may be damaged.

Note 4) Do not use the product in an atmosphere and place where there is direct contact with chemicals. It may cause damage to the body. (Alcohol, acetone, etc. also cause damage, so be sure for the product not to be close to them.)

⚠ For safe operation, be sure to read the Safety Instructions on front matters 38 and 39 before handling.

Compact Vacuum Ejector

Series ZA

Total length
72.9 mm

Total width
9.9 mm

Total height
52.5 mm

Mass 50 g

Possible to be mounted on moving parts thanks to lightweight

Response time
40 ms

Response time for up to -60 kPa
Nozzle diameter: $\phi 0.7$
Piping: $\phi 4/\phi 2.5 \times 100$ mm

Able to install on the moving parts

Shortened tube length to pad makes the response time improved.

■ **Supply pilot valve**

- Normally closed
- Latching

■ **Release valve**

- Normally closed

■ **Available with or without pressure sensor**

2 kinds of pressure range are selectable.

- 0 to -101 kPa
- -100 to 100 kPa

■ **Suction filter**

- Nominal filtration rating: 30 μ m

ZA

ZX

ZR

ZM

ZMA

ZQ

ZH

ZU

ZL

ZY□

ZF□

ZP□

SP

ZCUK

AMJ

AMV

AEP

HEP

Related Equipment

Compact Vacuum Ejector

Series ZA

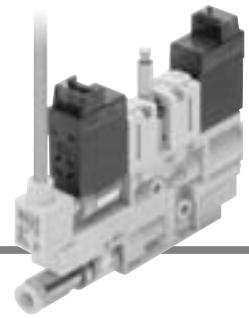

How to Order

Ejector Unit

ZA1071-K15L-P1-01

Nozzle nominal size

05	ø0.5
07	ø0.7

Solenoid valve combination (Refer to Table (1).)

Symbol	For supply	For release
K1	Normally closed	Normally closed
J1	Normally closed	None
Q1	Latching positive common	Normally closed
Q2	Latching positive common	None
N1	Latching negative common	Normally closed
N2	Latching negative common	None

Pilot valve (Refer to Table (1).)

Nil	Standard (1 W for DC) ^{Note}
Y	DC low wattage type (0.5 W) ^{Note}

Note) Avoid energizing the solenoid valve for long periods of time. (Refer to Design and Selection on Specific Product Precautions 1.)

Power supply voltage (Refer to Table (1).)

1	100 VAC (50/60 Hz)
2	200 VAC (50/60 Hz)
3	110 VAC (50/60 Hz)
4	220 VAC (50/60 Hz)
5	24 VDC
6	12 VDC

Electrical entry

L	L plug connector, with 0.3 m lead wire, with light/surge voltage suppressor	
LO	L plug connector, without connector, with light/surge voltage suppressor	
M	M plug connector, with 0.3 m lead wire, with light/surge voltage suppressor	
MO	M plug connector, without connector, with light/surge voltage suppressor	
G	Grommet, with 0.3 m lead wire (Not available for latching and AC types.)	

Vacuum (V) port

Symbol	Applicable tubing O.D.	Part no.
1	ø3.2 (Straight)	KJS23-M5
2	ø4 (Straight)	KJS04-M5
4	ø3.2 (Elbow)	KJL23-M5
5	ø4 (Elbow)	KJL04-M5

Air pressure supply (P) port

Symbol	Applicable tubing O.D.	Part no.
0	Without fitting (M3 x 0.5)	—
2	ø4 (Straight)	KJS04-M3
5	ø4 (Elbow)	KJL04-M3
M	Without supply ^{Note} adapter (For manifold)	Refer to "Construction". (page 853)

Note) O-ring and round head combination screws (M2 x 12) are attached to the supply adapter (M).

Pressure sensor specifications

Symbol	Rated pressure range and accuracy	Part no.
P1	With pressure sensor (0 to -101 kPa, accuracy ±2% F.S.)	PSE541
P1A	With pressure sensor (0 to -101 kPa, accuracy ±1% F.S.)	PSE541A
P3	With pressure sensor (-100 to 100 kPa, accuracy ±2% F.S.)	PSE543
P3A	With pressure sensor (-100 to 100 kPa, accuracy ±1% F.S.)	PSE543A
B	Without pressure sensor ^{Note 1}	KQ2P-04

Note 1) One-touch fittings are plugged when the pressure sensor is mounted.

Note 2) This pressure switch detects pressure and converts the data into analog output. When the product is used as a vacuum switch, a pressure sensor controller Series PSE300 (CAT.ES100-56) is necessary.

Suction filter

Nil	Without suction filter
F	With suction filter

Manual override

Nil	Non-locking push type
B	Locking type

Table (1) Combination of Solenoid Valve, Pilot Valve and Power Supply Voltage

Combination no.	Solenoid valve combination symbol	Pilot valve symbol	Applicable power supply voltage (V)					
			1 100 AC	2 200 AC	3 110 AC	4 220 AC	5 24 DC	6 12 DC
①	K1	Nil	—	—	—	—	●	●
②	K1	Y	—	—	—	—	●	●
③	J1	Nil	●	●	●	●	●	●
④	J1	Y	—	—	—	—	●	●
⑤	Q1	Nil	—	—	—	—	●	●
⑥	Q2	Nil	●	●	●	●	●	●
⑦	N1	Nil	—	—	—	—	●	●
⑧	N2	Nil	—	—	—	—	●	●

* Combinations (1) to (8) in the above table are the only possible options.

Warning

The filter case of this suction filter is made of nylon. The product will be damaged if solvents such as alcohol or chemicals are splashed on it. Avoid using it in an atmosphere where such solvents are present. This suction filter is exclusive to Series ZA. Do not use for other purposes.

How to Order

Manifold

ZZA1 08 - 3 P



Number of stations

01	1 station
02	2 stations
⋮	⋮
08	8 stations

• Right common air pressure supply (P) port (viewed from the vacuum (V) port side)

Symbol	Applicable tubing O.D.	Part no.
0	Without fitting (M5 x 0.8)	—
2	ø4 (Straight)	KJS04-M5
3	ø6 (Straight)	KJS06-M5
5	ø4 (Elbow)	KJL04-M5
6	ø6 (Elbow)	KJL06-M5
P	With plug	M-5P

• Left common air pressure supply (P) port (viewed from the vacuum (V) port side)

Symbol	Applicable tubing O.D.	Part no.
0	Without fitting (M5 x 0.8)	—
2	ø4 (Straight)	KJS04-M5
3	ø6 (Straight)	KJS06-M5
5	ø4 (Elbow)	KJL04-M5
6	ø6 (Elbow)	KJL06-M5
P	With plug	M-5P

Maximum Simultaneous Operating Stations

Manifold model	Ejector nozzle diameter	
	ø0.5	ø0.7
ZZA1 Stations -2P (KJ04-M5 one side) -5P (KJL04-M5 one side)	4 stations	2 stations
ZZA1 Stations -22 (KJ04-M5 both sides) -55 (KJL04-M5 both sides)	8 stations	4 stations
ZZA1 Stations -3P (KJS06-M5 one side)	8 stations	4 stations
ZZA1 Stations -6P (KJL06-M5 one side)	6 stations	3 stations
ZZA1 Stations -33 (KJS06-M5 both sides)	8 stations	8 stations
ZZA1 Stations -66 (KJL06-M5 both sides)	8 stations	6 stations

Manifold Ordering Example

- ZZA108-2P → 1 pc.
- *ZA1071-K15L-FP1-M2 → 4 pcs. (Stations 1 to 4)
- *ZA1051-Q15L-FB-M1 → 3 pcs. (Stations 5 to 7)
- *ZA1-BP1 → 1 pc. (Station 8)

Blanking plate assembly

Note) The stations are sequentially numbered. When viewed from the side of the vacuum ports, the far left station is designated as station 1.

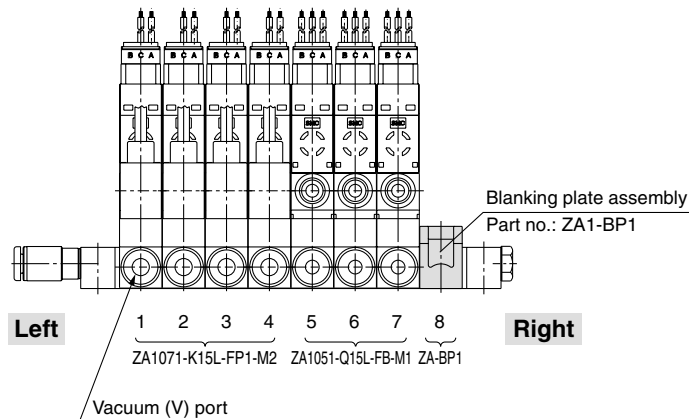

Flow Characteristics / Exhaust Characteristics

ZA05 Exhaust Characteristics

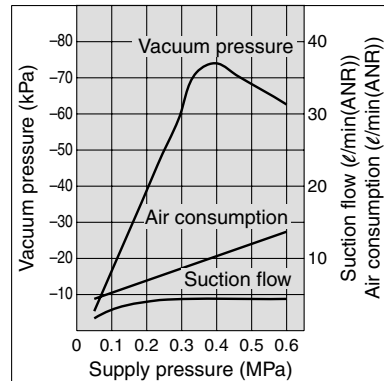

ZA05 Flow Characteristics

Supply pressure: 0.4 MPa

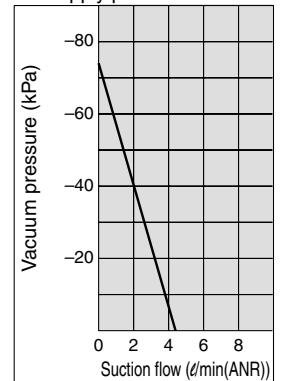

ZA07 Exhaust Characteristics

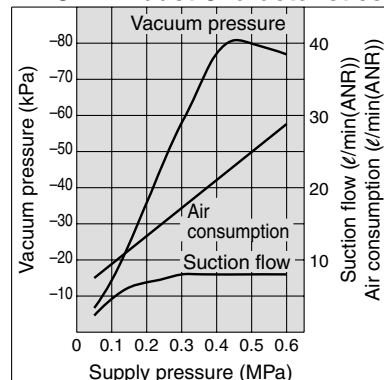

ZA07 Flow Characteristics

Supply pressure: 0.45 MPa

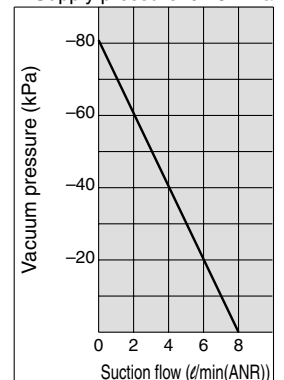

ZA
ZX
ZR
ZM
ZMA
ZQ
ZH
ZU
ZL
ZY□
ZF□
ZP□
SP
ZCUK
AMJ
AMV
AEP
HEP

Related Equipment

Specifications

General Specifications

Maximum operating pressure	0.50 MPa
Minimum operating pressure	0.20 MPa
Operating temperature range	5 to 50°C (No condensation)
Fluid	Air
Vibration resistance ^{Note)}	30 m/s ²

Note) There was no malfunction confirmed when tested under the following conditions: From 10 to 500 to 10 Hz and whichever of the following is smaller: 1.5 mm amplitude or 98 m/s² acceleration in X, Y, Z direction for 2 hours each. (initial value)

Ejector

Nozzle nominal diameter	0.5 mm	0.7 mm
Standard supply pressure ^{Note)}	0.40 MPa	0.45 MPa
Maximum vacuum pressure ^{Note)}	-74 kPa	-78 kPa
Maximum suction flow	4 ℓ/min (ANR)	8 ℓ/min (ANR)
Air consumption	12 ℓ/min (ANR)	28 ℓ/min (ANR)

Note) The maximum vacuum pressure was determined by applying the standard supply pressure. Different supply pressures are required to determine a model.

Pressure Sensor

Model	PSE541	PSE541A	PSE543	PSE543A
Rated pressure range	0 to -101 kPa		-100 to 100 kPa	
Proof pressure	500 kPa			
Fluid	Air, Non-corrosive gas, Non-flammable gas			
Output voltage	1 to 5 VDC (within rated pressure range)			
Output impedance	Approx. 1 kΩ			
Power supply voltage	12 to 24 VDC, Ripple (p-p) 10% or less (with power supply polarity protection)			
Current consumption	15 mA or less			
Accuracy (Ambient temperature 25°C)	±2% F.S. or less	±1% F.S. or less	±2% F.S. or less	±1% F.S. or less
Linearity	±0.4% F.S. or less			
Repeatability	±0.2% F.S. or less Effects to the output value due to supply voltage: ±0.8% F.S. or less			
Temperature characteristics	±2% F.S. or less (based on 25°C)			
Enclosure	IP40			
Ambient humidity range	Operating/Stored: 35 to 80% RH (No condensation)			
Withstand voltage	1000 VAC or more, 50/60 Hz for 1 minute between live parts and housing			
Insulation resistance	50 MΩ or more between live parts and housing (at 500 VDC mega)			

Mass

Single unit	
With pressure sensor	50 g
Without pressure sensor	45 g
Manifold base	
1 station	9 g
2 stations	11 g
3 stations	13 g
4 stations	15 g
5 stations	17 g
6 stations	19 g
7 stations	21 g
8 stations	23 g

● Calculation of mass for the manifold type
(Single unit mass) x (Number of stations)
+ (Manifold base)

Example) 5 stations manifold with pressure sensors

$$50 \text{ (g)} \times 5 + 17 \text{ (g)} = 267 \text{ (g)}$$

Construction

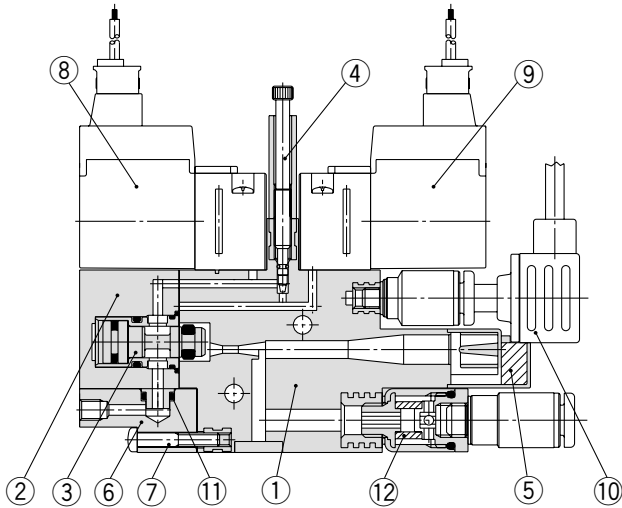

Component Parts

No.	Description	Material
1	Body	PBT
2	Valve cover	PBT

Replacement Parts

No.	Description	Part no.
3	Poppet valve assembly	
4	Release flow adjusting needle assembly	
5	Sound absorbing material	ZA1-SAE2
6	Supply adapter	XT631-ZA1-KA2
7*	Round head combination screw	M2 x 12
8	Supply pilot valve	VQ110□-□□□
9	Release valve	VQ110-□□□
10	Pressure sensor	PSE54□□-R04
11*	O-ring	ø3.0 x ø1.0
12	Filter element	ZA1-FE-30

* For above parts of No. 7 and No. 11, the parts assembly ZA1-OP-1 (10 pcs each) is available.

How to Order

Solenoid Valve

VQ110 □ - **5** **L** □

Pilot valve

Nil	Standard (1 W)
Y	Low wattage type (0.5 W) * Not applicable to AC type.
L	Latching positive common
N	Latching negative common

Rated coil voltage

1	100 VAC
2	200 VAC
3	110 VAC
4	220 VAC
5	24 VDC
6	12 VDC

Solenoid valve connector assembly part no.

Manual override

Nil	Non-locking push type
B	Locking type

Electrical entry

L	L plug connector, with 0.3 m lead wire	
LO	L plug connector, without connector, with light/surge voltage suppressor	
M	M plug connector, with 0.3 m lead wire	
MO	M plug connector, without connector, with light/surge voltage suppressor	
G	Grommet, with 0.3 m lead wire (Not available for latching and AC types.)	

How to order connector assembly

DC positive common

• Single

AXT661-14A-

• Latching

AXT661-13A-

DC negative common

• Latching

AXT661-13AN-

100 VAC

• Single

AXT661-31A-

• Latching

AXT661-32A-

200 VAC

• Single

AXT661-34A-

• Latching

AXT661-35A-

Connector, socket (3 pcs) only

AXT661-12A

Lead wire length

Nil	300 mm
6	600 mm
10	1000 mm
20	2000 mm
30	3000 mm

Lead-wire length of the plug connector

The lead-wire length for a valve with a lead-wire is 300 mm. When in need of a valve with a lead-wire longer than 600 mm, place an order for a valve without a connector and connector assembly.

Vacuum Pressure Switch

PSE54 **1** □ - **R04**

Rated pressure range

1	0 to -101 kPa
3	-100 to 100 kPa

Accuracy

Nil	±2% F.S. or less
A	±1% F.S. or less

Series ZA

Dimensions

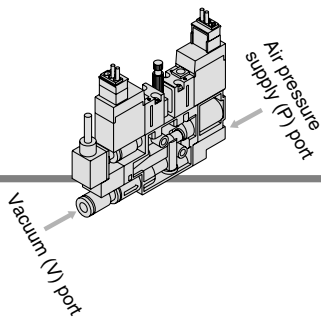

Type K1

ZA1□□1-K1□□□□-□□□□-□□

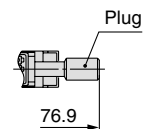
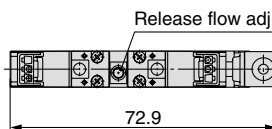

ZA1□□1-K1□□□□-□□B-□□

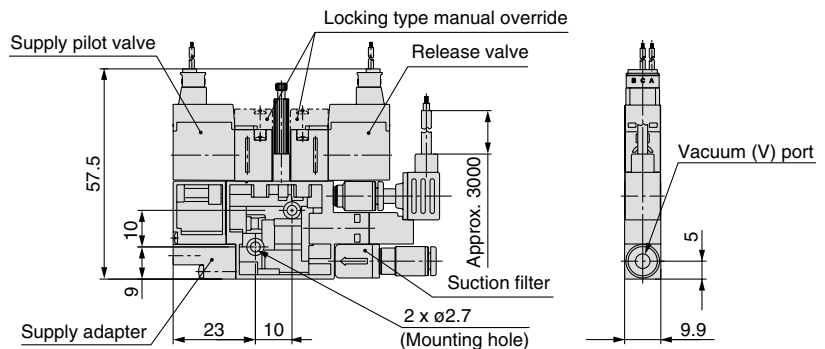
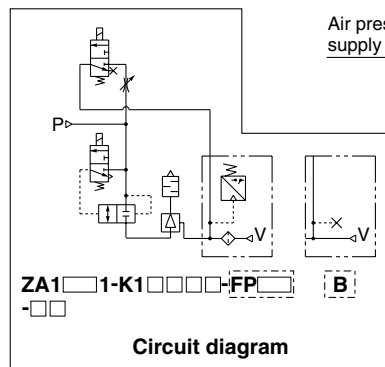

ZA1□□1-K1□□L□-FP□□-02

Note) When the body is mounted, tighten with a torque of 0.6 ± 0.06 N·m. Using excessive torque may cause damage to the body.

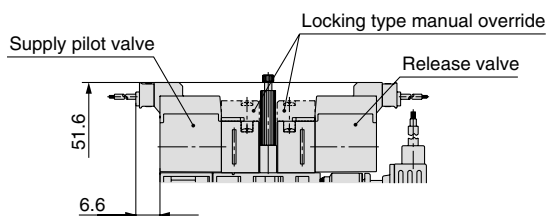

ZA1□□1-K1□□M□-□□□□-□□

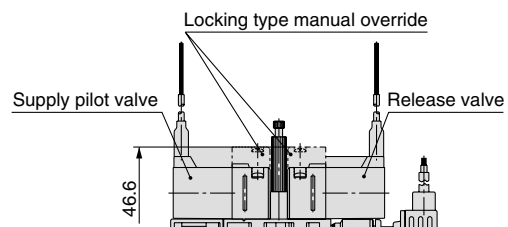

ZA1□□1-K1□□G□-□□□□-□□

Dimensions of the vacuum (V) and air pressure supply (P) port fittings after installation

Dimensions after the fittings are installed on the vacuum (V) port, air pressure supply (P) port of a single unit, and the common air pressure supply (P) port of a manifold are shown below.

Applicable tubing O.D.: ø3.2

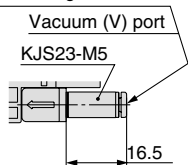

ZA1□□1-K1□□□□-□□□□-01

Applicable tubing O.D.: ø4

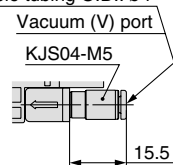

ZA1□□1-K1□□□□-□□□□-02

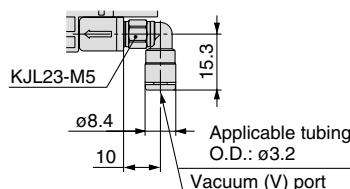

ZA1□□1-K1□□□□-□□□□-04

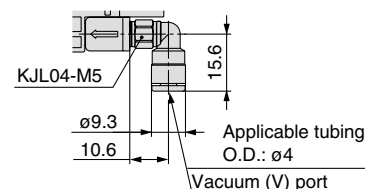

ZA1□□1-K1□□□□-□□□□-05

Dimensions of the vacuum (V) port fittings after installation

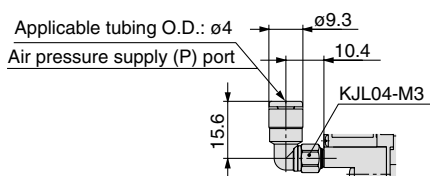

ZA1□□1-K1□□□□-□□□□-5□

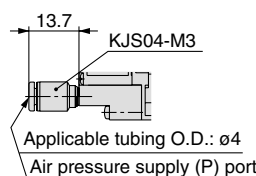

ZA1□□1-K1□□□□-□□□□-2□

Dimensions of the air pressure supply (P) port fittings after installation

Dimensions

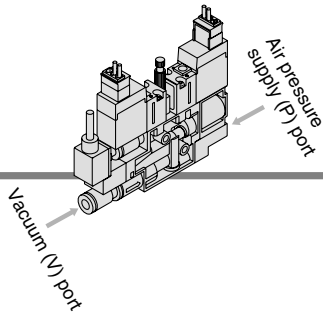

Type J1

ZA1□□1-J1□□□□-□□□□

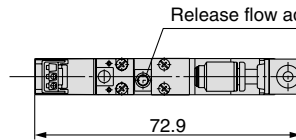

ZA1□□1-J1□□□□-□B-□□

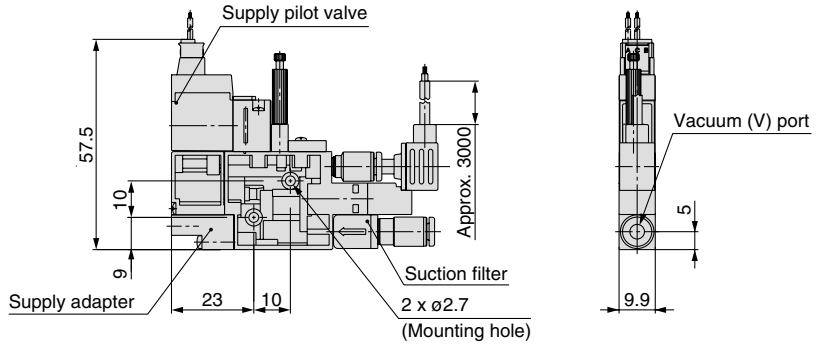
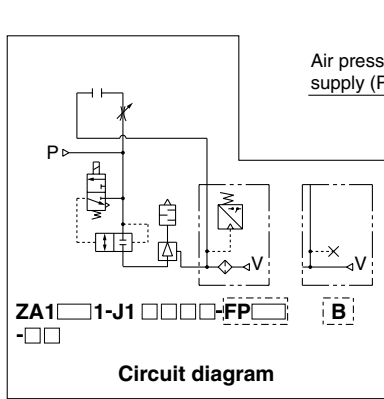

ZA1□□1-J1□□□□-FP□□-02

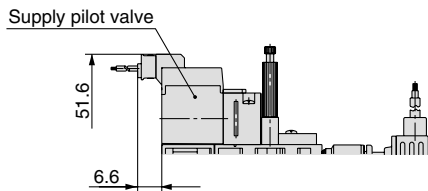

ZA1□□1-J1□□□□-M□□□□-□□

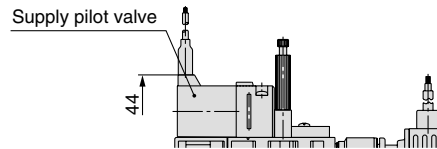

ZA1□□1-J1□□□□-G□□□□-□□

Dimensions of the vacuum (V) and air pressure supply (P) port fittings after installation

Dimensions after the fittings are installed on the vacuum (V) port, air pressure supply (P) port of a single unit, and the common air pressure supply (P) port of a manifold are shown below.

Applicable tubing O.D.: $\phi 3.2$

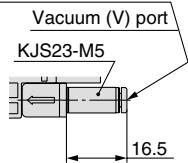

ZA1□□1-J1□□□□-□□□□-01

Applicable tubing O.D.: $\phi 4$

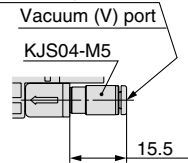

ZA1□□1-J1□□□□-□□□□-02

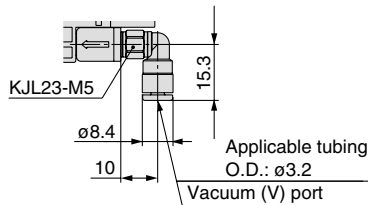

ZA1□□1-J1□□□□-□□□□-04

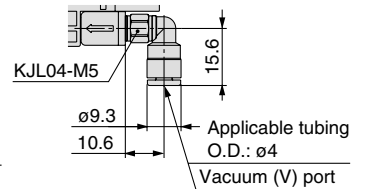

ZA1□□1-J1□□□□-□□□□-05

Dimensions of the vacuum (V) port fittings after installation

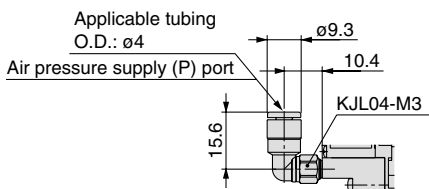

ZA1□□1-J1□□□□-□□□□-5□

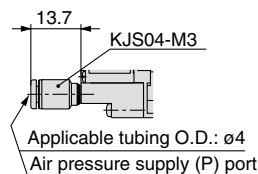

ZA1□□1-J1□□□□-□□□□-2□

Dimensions of the air pressure supply (P) port fittings after installation

ZA

ZX

ZR

ZM

ZMA

ZQ

ZH

ZU

ZL

ZY□

ZF□

ZP□

SP

ZCUK

AMJ

AMV

AEP

HEP

Related Equipment

Series ZA

Dimensions

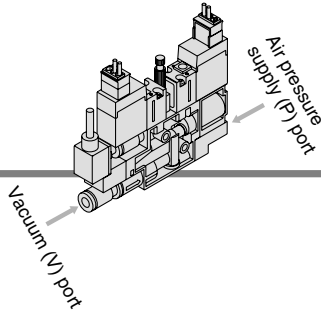

Type Q_1
 N_1
ZA1 □ □ □ □ $1-Q_1$ □ □ □ □ □ □ □ □

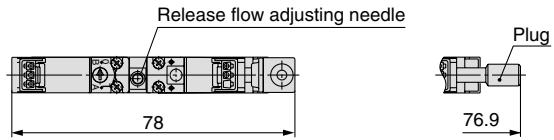

ZA1 □ □ □ □ $1-Q_1$ □ □ □ □ □ □ □ □ **B** □ □

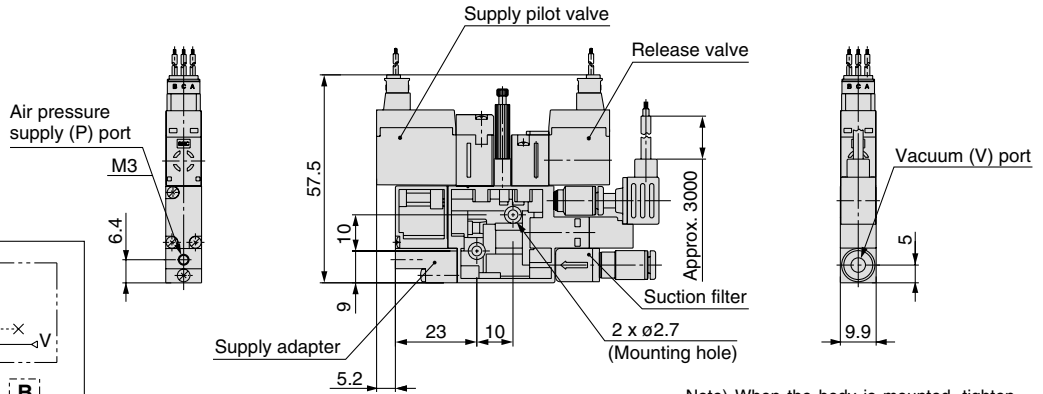
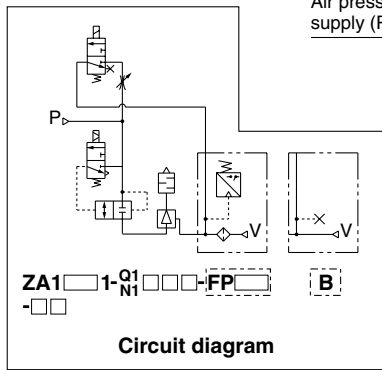

ZA1 □ □ □ □ $1-Q_1$ □ □ □ □ □ □ □ □ **LP** □ □ □ □ □ □ □ □ **02**

Note) When the body is mounted, tighten with a torque of 0.6 ± 0.06 N·m. Using excessive torque may cause damage to the body.

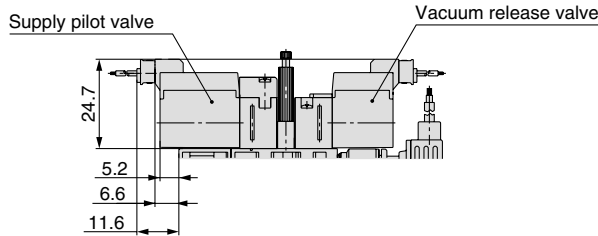

ZA1 □ □ □ □ $1-Q_1$ □ □ □ □ □ □ □ □ □ □ □ □ □ □

Dimensions of the vacuum (V) and air pressure supply (P) port fittings after installation

Dimensions after the fittings are installed on the vacuum (V) port, air pressure supply (P) port of a single unit, and the common air pressure supply (P) port of a manifold are shown below.

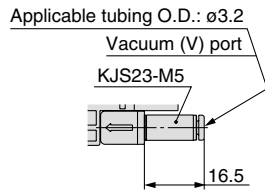

ZA1 □ □ □ □ $1-Q_1$ □ □ □ □ □ □ □ □ □ □ □ □ □ □

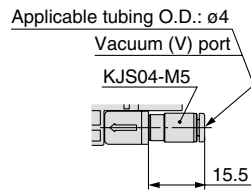

ZA1 □ □ □ □ $1-Q_1$ □ □ □ □ □ □ □ □ □ □ □ □ □ □

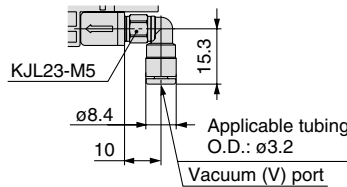

ZA1 □ □ □ □ $1-Q_1$ □ □ □ □ □ □ □ □ □ □ □ □ □ □

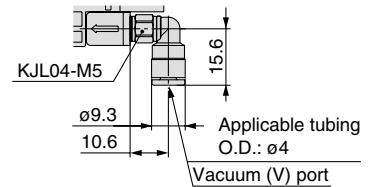

ZA1 □ □ □ □ $1-Q_1$ □ □ □ □ □ □ □ □ □ □ □ □ □ □

Dimensions of the vacuum (V) port fittings after installation

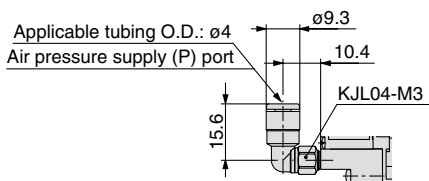

ZA1 □ □ □ □ $1-Q_1$ □ □ □ □ □ □ □ □ □ □ □ □ □ □

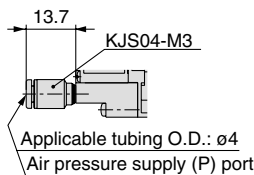

ZA1 □ □ □ □ $1-Q_1$ □ □ □ □ □ □ □ □ □ □ □ □ □ □

Dimensions of the air pressure supply (P) port fittings after installation

Dimensions

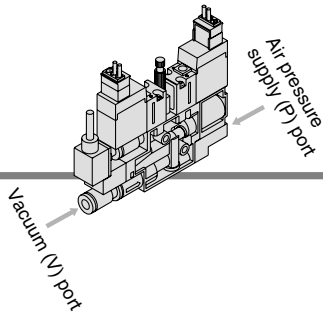

Type $\frac{Q2}{N2}$
ZA1 1- $\frac{Q2}{N2}$

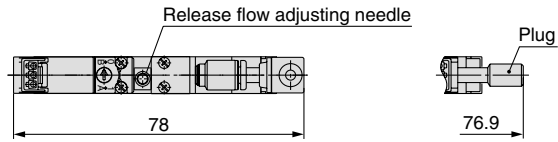

ZA1 1- $\frac{Q2}{N2}$ **B**

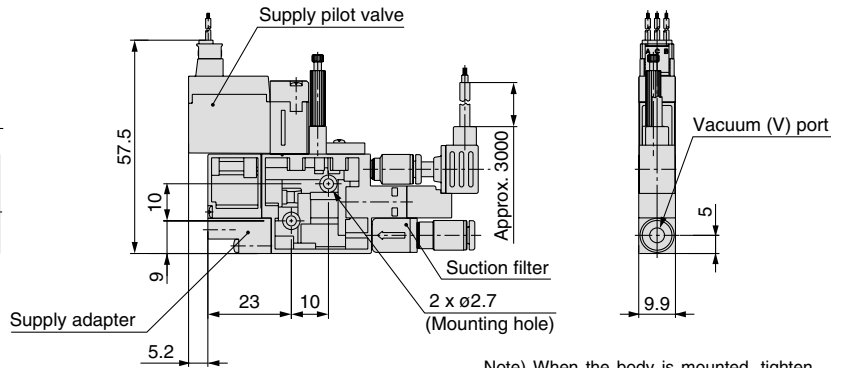
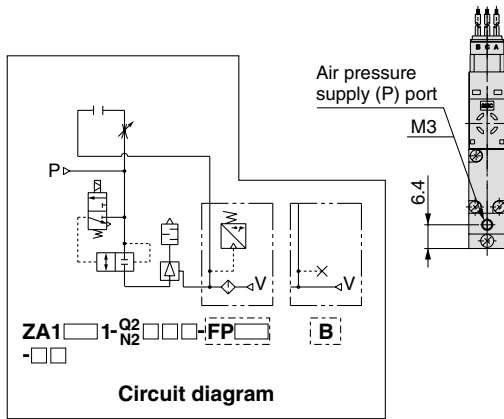

ZA1 1- $\frac{Q2}{N2}$ **FP** **02**

Note) When the body is mounted, tighten with a torque of 0.6 ± 0.06 N·m. Using excessive torque may cause damage to the body.

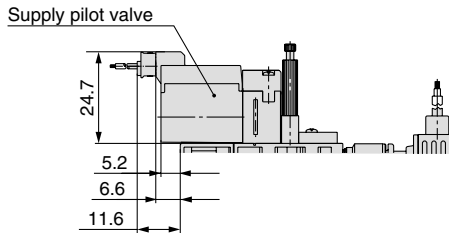

ZA1 1- $\frac{Q2}{N2}$ **M**

Dimensions of the vacuum (V) and air pressure supply (P) port fittings after installation

Dimensions after the fittings are installed on the vacuum (V) port, air pressure supply (P) port of a single unit, and the common air pressure supply (P) port of a manifold are shown below.

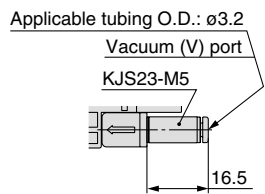

ZA1 1- $\frac{Q2}{N2}$

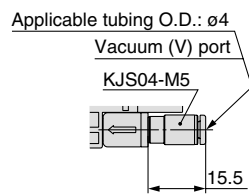

ZA1 1- $\frac{Q2}{N2}$

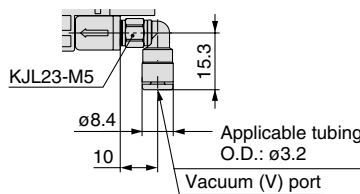

ZA1 1- $\frac{Q2}{N2}$

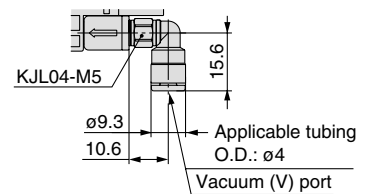

ZA1 1- $\frac{Q2}{N2}$

Dimensions of the vacuum (V) port fittings after installation

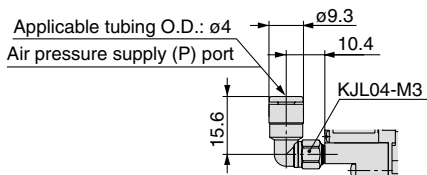

ZA1 1- $\frac{Q2}{N2}$ **5**

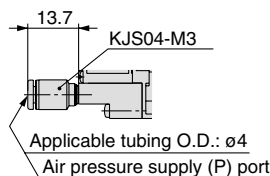

ZA1 1- $\frac{Q2}{N2}$ **2**

Dimensions of the air pressure supply (P) port fittings after installation

ZA
ZX
ZR
ZM
ZMA
ZQ
ZH
ZU
ZL
ZY <input type="checkbox"/>
ZF <input type="checkbox"/>
ZP <input type="checkbox"/>
SP
ZCUK
AMJ
AMV
AEP
HEP
Related Equipment

Manifold Type: How to Increase / Decrease Manifold Stations

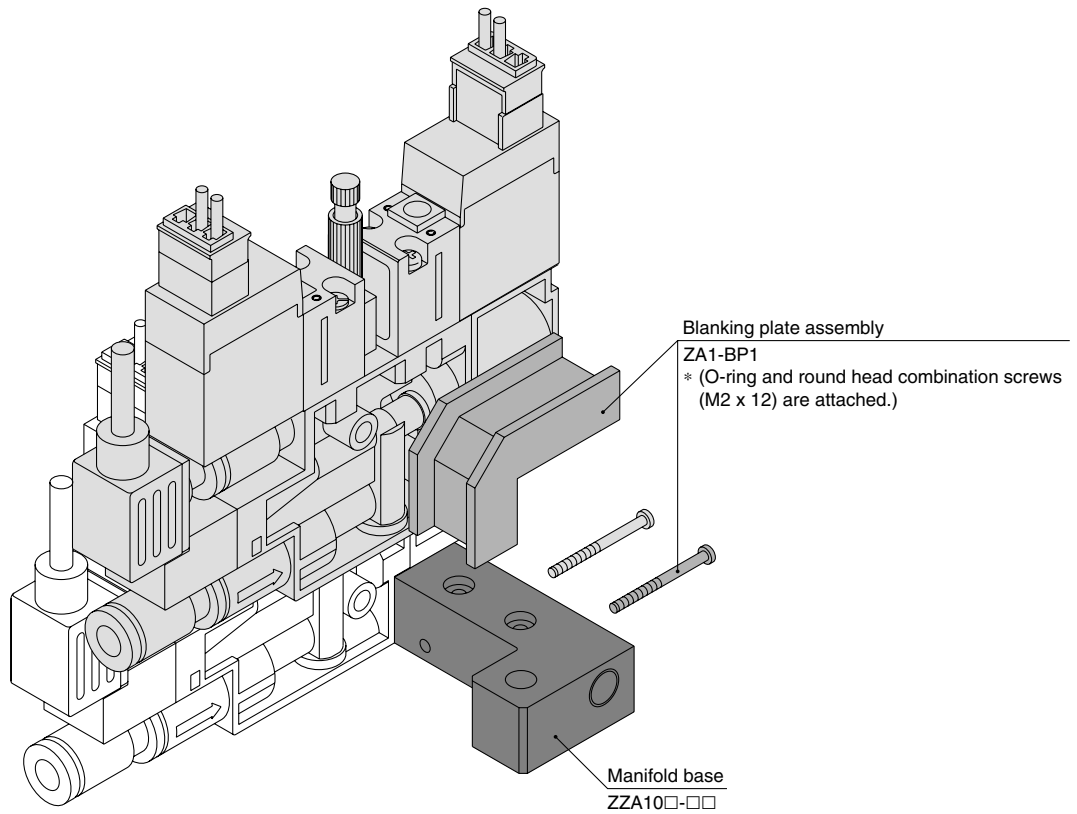

* An assembly kit (part no. ZA1-OP-1) is available which includes 10 pcs each of O-rings and round head combination screws.

ZA
ZX
ZR
ZM
ZMA
ZQ
ZH
ZU
ZL
ZY□
ZF□
ZP□
SP
ZCUK
AMJ
AMV
AEP
HEP
Related Equipment



Series ZA Specific Product Precautions 1

Be sure to read before handling. Refer to front matters 38 and 39 for Safety Instructions and pages 844 to 846 for Vacuum Equipment Precautions.

Design and Selection

Warning

1. Avoid energizing the solenoid valve for long periods of time.

If a solenoid valve is energized for a long period of time, the coil will get hot and the performance may be reduced. Additionally, the peripheral equipment in close proximity may also be badly affected. Use a low wattage solenoid valve when the solenoid valve is energized continuously or when the duration of the energization is longer than the non-energized period each day. Periods of energization can be shortened by using a normally opened or latching type solenoid valve. But, do not energize the coil on both A and B sides simultaneously when using the latching type.

Continuous energization of the solenoid valve should be less than 10 minutes in duration and the energization period should be shorter than the non-energized period. Take measures for any heat radiation so that the temperature is within the range of solenoid valve specifications when the solenoid valve is mounted on the control panel. Please pay special attention to any temperature increases when a manifold type with 3 stations or more is energized continuously or when three individual units are placed in close proximity.

2. Use the vacuum equipment within the operating supply pressure range.

When the operating with a lower supply pressure, the vacuum performance will be reduced and the poppet valve will cause malfunction.

Never use the vacuum equipment more than the operating supply pressure range as this may cause damage to the product resulting in potentially dangerous operation.

3. Suspension of operation for long periods of time

Please use caution — as detailed below — when the vacuum equipment is turned off for periods in excess of 6 hours.

- Be sure to turn off the pressure supply to the vacuum equipment.

Please observe this precautions as the supply pressure will be applied for a extra period of time due to the line pressure increase and may result in damage to the vacuum equipment.

- Be sure to turn off the power supply to the solenoid valve and the pressure switch.

Please observe this precautions as any heat generated due to the length of energization time may seriously affect the vacuum equipment and peripheral equipment resulting in potentially dangerous operation.

4. Exhaust port (EXH port) on the vacuum ejector

Please check the exhaust port (EXH port) on the vacuum ejector, so that any exhaust resistance will not be increased due to insulating materials or restrictions in the piping. The exhaust resistance may reduce the ejector's performance. Additionally, never use this product in an application where the exhaust port is blocked when detaching a workpiece. This misuse may result in possible damage to the product.

5. Vacuum release flow adjusting needle

Adjust the vacuum release flow adjusting needle from the fully closed to the open state by 1/8 to 1/4 turns to detach a workpiece completely during the ON time of a release valve.

Do not supply compressed air while the vacuum release flow adjusting needle is adjusted. Securely lock it with a lock nut after adjustment.

Warning

6. How to use the latching type solenoid valve

Our Latching type solenoid are fitted with a self-detaining mechanism. Its construction features an armature inside the solenoid which is set or reset using spontaneous energization. (10 ms or greater) Therefore, continuous energization is not required.

How to Use the Latching Type Plug Connector

Wiring specifications

- Wiring should be connected as shown below. Connect with the power supply respectively.

DC positive common

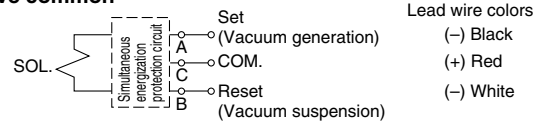

DC negative common

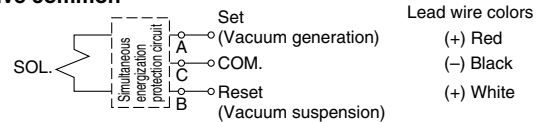

AC type

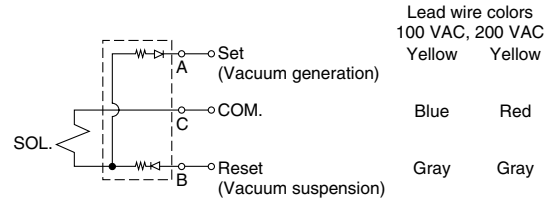

Special care must be taken for the latching type.

- Avoid using this product with a circuit which electrifies both the set and reset signals simultaneously.
- The minimum energization time required for self-detaining is 10 ms.
- Please contact us when using this product in locations where there are vibration levels of 30 m/s² or above or highly magnetic fields. No problems arise in normal usage or locations.
- This valve retains the reset position (Flow path: A → R) at the time of shipment. However, it may alter to the set position during transportation or due to vibration when mounting the valve. Therefore, confirm the home position either manually or with power supply prior to use.

7. Suction filter

This suction filter is dedicated to the ZA series. Avoid using it for other purposes.



Series ZA Specific Product Precautions 2

Be sure to read before handling. Refer to front matters 38 and 39 for Safety Instructions and pages 844 to 846 for Vacuum Equipment Precautions.

Mounting

Warning

1. When the body is mounted, tighten with a torque of 0.6 ± 0.06 N·m.

Using excessive torque may cause damage to the body.

Operating Environment

Warning

1. Suction filter

The filter case of this suction filter is made of nylon. The product will be damaged if solvents such as alcohol or chemicals are splashed on it. Avoid using it in an atmosphere where such solvents are present.

ZA

ZX

ZR

ZM

ZMA

ZQ

ZH

ZU

ZL

ZY□

ZF□

ZP□

SP

ZCUK

AMJ

AMV









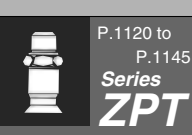

AEP

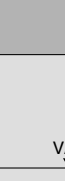

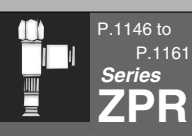

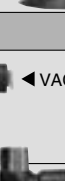

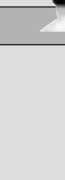
HEP

Related
Equipment

Vacuum Pad

Series ZP

Type	Without buffer			With buffer		
	Vacuum entry port	Mounting	VAC	Vacuum entry port	Mounting	VAC
 P.1120 to P.1145 Series ZPT Vertical vacuum entry	Male thread	(Common)		Female thread	Buffer body	
	Female thread	(Common)		Barb fitting	Buffer body	
				One-touch fitting	Buffer body	
 P.1146 to P.1161 Series ZPR Lateral vacuum entry with One-touch fitting	One-touch fitting	Male thread		One-touch fitting	Buffer body	
	One-touch fitting	Female thread				
 P.1162 to P.1177 Series ZPY Lateral vacuum entry with Barb fitting	Barb fitting	Male thread		Barb fitting	Buffer body	
	Barb fitting	Female thread				

Pad form (Compatible with all models)	Flat (U)  Flat with ribs (C)  Deep (D)  Bellows (B)  Thin flat (UT)  Thin flat with ribs (CT) 
---	--

Pad diameter	2 x 4	3.5 x 7	4 x 10	ø2	ø4	ø6	ø8	ø10	ø13	ø16	ø20	ø25	ø32	ø40	ø50
Flat	●	●	●	●	●	●	●	●	●	●	●	●	●	●	●
Flat with ribs	—	—	—	—	—	—	●	●	●	●	●	●	●	●	●
Deep	—	—	—	—	—	—	●	●	●	●	●	●	●	●	●
Bellows	—	—	—	—	—	●	●	●	●	●	●	●	●	●	●
Thin flat	—	—	—	—	—	—	—	●	●	●	—	—	—	—	—
Thin flat with ribs	—	—	—	—	—	—	—	●	●	●	—	—	—	—	—

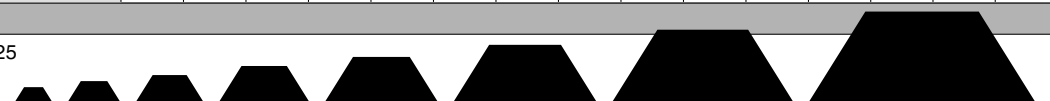
Pad diameter (ø2 to ø125)	
-------------------------------------	--

Pad material	NBR (Black), Silicon rubber (White), Urethane rubber (Brown), Fluoro rubber (Black with green mark), Conductive NBR (Black with one silver mark), Conductive silicon rubber (Black with two silver marks)
---------------------	--

 **Pad selection** Refer to the vacuum equipment model selection on pages 828 to 834 for the calculation of lift force and response time.

Pad Material and Characteristics

◎: Little or no influence ○: Can be used depending on conditions X: Not suitable

Material	Characteristics	Durometer HS (±5°)	Operating temperature range (°C)	Oil resistance gasoline	Oil resistance benzol	Base resistance	Acid resistance	Weatherability	Ozone resistance	Abrasion resistance	Waterproof	Solvent resistance (Benzene, toluene)
NBR		50°	0 to 120	◎	X	○	○	X	X	◎	○	X
Silicon rubber		40°	-30 to 200	X	X	○	X	◎	◎	X	○	X
Urethane rubber		60°	0 to 60	◎	X	X	X	○	◎	◎	X	X
Fluoro rubber		60°	0 to 250	◎	◎	X	◎	◎	◎	○	◎	◎
Conductive NBR		50°	0 to 100	○	X	○	○	○	X	○	○	X
Conductive silicon rubber		50°	-10 to 200	X	X	○	X	◎	◎	X	○	X

* The above table covers only general characteristics of subject rubber materials. Pad materials used by SMC pass the JIS standards; however the actual performance depends on operating conditions.

- ZA
- ZX
- ZR
- ZM
- ZMA
- ZQ
- ZH
- ZU
- ZL
- ZY□
- ZF□
- ZP□
- SP
- ZCUK
- AMJ
- AMV
- AEP
- HEP
- Related Equipment



Vacuum Pad/ Vertical Vacuum Entry Without Buffer

Series ZPT



Specifications

Vacuum entry	Direction		Vertical	
	Connection		Male thread	Female thread
Thread diameter	$\phi 2$ to $\phi 8$ Elliptic (2 x 4, 3.5 x 7, 4 x 10) Thin section series ($\phi 10$ to $\phi 16$)		M5 x 0.8, M6 x 1	M4 x 0.7, M5 x 0.8
	$\phi 10$ to $\phi 16$		M5 x 0.8, M6 x 1	M5 x 0.8, M6 x 1 1/8 (Rc, NPT, NPTF)
	$\phi 20$ to $\phi 32$		M6 x 1, M8 x 1	M5 x 0.8, M6 x 1, M8 x 1.25 1/8 (Rc, NPT, NPTF)
	$\phi 40, \phi 50$		M6 x 1, M8 x 1	M6 x 1, M8 x 1.25 1/8 (Rc, NPT, NPTF)
Mounting			Use connection for vacuum entry	

Pad Type

Pad form	Flat	Flat with ribs	Deep	Bellows	Thin flat/Thin flat with ribs
Pad diameter (mm)	2, 4, 6, 8, 2 x 4, 3.5 x 7, 4 x 10, 10, 13, 16, 20, 25, 32, 40, 50	10, 13, 16, 20, 25, 32, 40, 50	10, 16, 25, 40	6, 8, 10, 13, 16, 20, 25, 32, 40, 50	10, 13, 16
Material (Color)	NBR (Black), Silicon rubber (White), Urethane rubber (Brown), Fluoro rubber (Black with green mark) Conductive NBR (Black with one silver mark), Conductive silicon rubber (Black with two silver marks)				
Durometer	NBR (50°), Silicon rubber (40°), Urethane rubber/Fluoro rubber (60°) Conductive NBR (50°), Conductive silicon rubber (50°)				

Mass/Male Thread (Female thread)

(g)

Model	Flat					Flat with ribs				Deep				Bellows					
	M4	M5	M6	M8	$\square 1/8$	M5	M6	M8	$\square 1/8$	M5	M6	M8	$\square 1/8$	M4	M5	M6	M8	$\square 1/8$	
ZPT02 to ZPT08	— (3.5)	2.5 (3)	3.5 (—)	—	—	—	—	—	—	—	—	—	—	— (3.5) (except $\phi 2, \phi 4$)	2.5 (3)	3.5 (—) (except $\phi 2, \phi 4$)	—	—	
ZPT10	—	—	—	—	—	—	—	—	—	10 (7)	12 (6)	— (13)	—	—	—	—	—	—	
ZPT13	—	10 (6.5)	12 (6)	—	— (13)	10 (6.5)	12 (6)	—	— (12)	—	—	—	—	—	10 (6.5)	12 (6)	—	— (13)	
ZPT16	—	—	—	—	—	—	—	—	—	11 (7)	15 (7)	15 (13)	—	—	—	—	—	—	
ZPT20	—	—	—	—	—	—	—	—	—	—	—	—	—	—	—	—	—	—	
ZPT25	—	— (8.5)	15 (8)	26 (17)	— (16)	— (8.5)	15 (8)	26 (17)	— (16)	—	15 (10)	15 (10)	— (18)	— (17)	—	— (8.5)	15 (8)	16 (17)	— (16)
ZPT32	—	—	—	—	—	—	—	—	—	—	—	—	—	—	—	—	—	—	
ZPT40	—	—	28 (26)	30 (25)	— (23)	—	28 (26)	30 (25)	— (16)	—	30 (28)	32 (26)	— (20)	—	—	—	28 (26)	30 (25)	— (23)
ZPT50	—	—	30 (29)	32 (27)	— (25)	—	32 (30)	34 (29)	— (27)	—	—	—	—	—	—	—	30 (29)	32 (27)	— (25)

* (): Figures for female thread connections

How to Order

Series ZPT
Without buffer

ZPT 02 U N - A5

Pad diameter
(mm)

2004	2 x 4
3507	3.5 x 7
4010	4 x 10
02	2
04	4
06	6
08	8
10	10
13	13
16	16
20	20
25	25
32	32
40	40
50	50

Vacuum entry/Mounting thread diameter

Connection	Symbol	Thread diameter	ø2 to ø8	ø10 to ø16	ø20 to ø32	ø40, ø50
			2 x 4, 3.5 x 7, 4 x 10 ø10 to ø16 (Thin section series)			
Male thread	A5	M5 x 0.8	●	●	—	—
	A6	M6 x 1	●	●	●	●
	A8	M8 x 1	—	—	●	●
Female thread	B4	M4 x 0.7	●	—	—	—
	B5	M5 x 0.8	●	●	●	—
	B6	M6 x 1	—	●	●	●
	B8	M8 x 1.25	—	—	●	●
	B01	Rc 1/8	—	●	●	●
	N01	NPT 1/8	—	●	●	●
	T01	NPTF 1/8	—	●	●	●

Material

N	NBR
S	Silicon rubber
U	Urethane rubber
F	Fluororubber
GN	Conductive NBR
GS	Conductive silicon rubber

Pad type

(Refer to "Table (1)" for applications.)



U	Flat
C	Flat with ribs
D	Deep
B	Bellows
UT	Thin flat
CT	Thin flat with ribs

Table (1) Pad Diameter/Pad Type

Type \ Diameter (mm)	Diameter (mm)															
	2 x 4	3.5 x 7	4 x 10	2	4	6	8	10	13	16	20	25	32	40	50	
Flat	●	●	●	●	●	●	●	●	●	●	●	●	●	●	●	
Flat with ribs	—	—	—	—	—	—	—	●	●	●	●	●	●	●	●	
Deep	—	—	—	—	—	—	—	—	—	●	—	—	—	—	—	
Bellows	—	—	—	—	—	●	●	●	●	●	●	●	●	●	●	
Thin flat	—	—	—	—	—	—	—	●	●	●	—	—	—	—	—	
Thin flat with ribs	—	—	—	—	—	—	—	●	●	●	—	—	—	—	—	

⚠ Precautions

Be sure to read before handling. Refer to front matters 38 and 39 for Safety Instructions and pages 844 to 846 for Vacuum Equipment Precautions.

Caution on Design

⚠ Warning

- In cases where workpieces are heavy or dangerous, etc., take measures to address a possible loss of adsorption force (installation of drop prevention guides, etc.).

In the case of transportation by vacuum adsorption using vacuum pads, adsorption force is lost when there is a drop in vacuum pressure. Furthermore, since vacuum pressure can also deteriorate due to wear and cracking of pads, and vacuum leakage from piping, etc., be certain to perform maintenance on vacuum equipment.

Selection

⚠ Caution

- The pad materials differ depending upon the operating environment.

An appropriate pad material should be selected. Furthermore, since vacuum pads are manufactured for use with industrial products, they should not have direct contact with pharmaceuticals or food products, etc.

- Depending upon the weight and shape of the workpieces, the diameter, quantity and shape of pads will vary.

Use the pad lifting force table for reference. Also, the pads selected will differ based upon conditions other than the above, such as the condition of the workpiece surface (presence or absence of oil or water), the workpiece material and its gas permeability. Confirmation is necessary by actually performing vacuum adsorption testing on the subject workpieces.

- Use a buffer for adsorption on fragile workpieces.

The cushioning by the buffer is necessary when there is variation in the height of workpieces. When further positioning of pads and workpieces is desired, a detent buffer can be used.

- The life of a buffer will be reduced if the lateral force is applied to the buffer shaft. Note that sometimes a load is applied to the buffer by a piping tube (pulling or pressing, etc. in a lateral direction).

- Do not apply an impact or large forces to a pad when adsorbing a workpiece.

This will cause deformation, cracking and wear of the pad to be accelerated. The stiffening ribs, etc. should touch lightly, while staying within the pad skirt's deformation range. Positioning should be performed accurately. Especially in the case of small diameter pads.

- When transporting in an upward direction, factors such as acceleration, wind pressure and impact force must be considered in addition to a workpiece weight.

Use caution particularly when lifting items such as glass plates and circuit boards, because a large force will be applied by the wind pressure. When a workpiece which is oriented vertically is transported horizontally, large forces are applied by acceleration when movement is started and stopped. Further, in cases where the pad and a workpiece can slip easily, accelerations and decelerations of horizontal movement should be kept low.

- When transporting flat workpieces that have large surface areas using multiple pads, care must be taken when arranging the pads to balance the workpiece.

Maintenance

⚠ Caution

- Perform pad maintenance regularly.

Since pads are essentially rubber, deterioration is unavoidable. The rate of deterioration depends upon factors such as conditions of use, environment and temperature. Regular maintenance should be performed. If any damage, splitting, cracking or abrasion has occurred in a pad which appears to be harmful, replace it immediately. Also, take care not to damage the outside of the pad.

ZA

ZX

ZR

ZM

ZMA

ZQ

ZH

ZU

ZL

ZY□

ZF□

ZP□

SP

ZCUK

AMJ

AMV

AEP

HEP

Related
Equipment

Series ZPT

Connection	Male thread	Pad Form	Flat/Flat with ribs/Deep/Thin flat/ Thin flat with ribs/Elliptic
Vacuum Entry Port	Vertical	Mounting	Use connection for vacuum entry

Thin flat/Thin flat with ribs $\varnothing 10, \varnothing 13, \varnothing 16$ /Elliptic 2004, 3507, 4010
 Size/Flat $\varnothing 2, \varnothing 4, \varnothing 6, \varnothing 8$ Size/ $\varnothing 20, \varnothing 25, \varnothing 32$

Flat/Thin flat/Thin flat with ribs

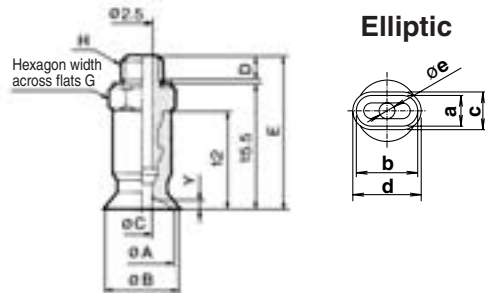

Flat

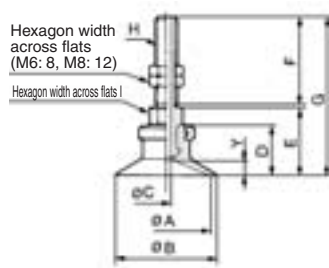

Deep: ZPT25D only

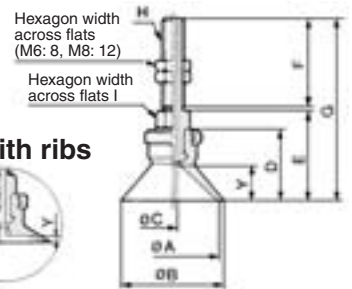

Flat with ribs



Flat/Thin Flat/Thin Flat with Ribs

Model	A	B	C	H: M5 x 0.8			H: M6 x 1			Y
				D	E	G	D	E	G	
ZPT02U	2	2.6	1.2	3	19	7	4	20	8	0.5
ZPT04U	4	4.8	1.6							0.8
ZPT06U	6	7	0.8							
ZPT08U	8	9	1							
ZPT10UT	10	11	1							
ZPT13UT	13	14	1.5							
ZPT16UT	16	17	1.5							
ZPT10CT	10	11	0.8							
ZPT13CT	13	14	0.8							
ZPT16CT	16	17	1							

Flat/Flat with Ribs

Model	A	B	D	H: M6 x 1					H: M8 x 1					Y	
				C	E	F	G	I	C	E	F	G	I	Flat	Flat with ribs
ZPT20 ^U _C	20	23	14	3	19	25	45	8	3.5	24	15	40	12	4	1.7
ZPT25 ^U _C	25	28													1.8
ZPT32 ^U _C	32	35	14.5		19.5		45.5			24.5		40.5		4.5	2.3

Deep

Model	A	B	D	H: M6 x 1					H: M8 x 1					Y
				C	E	F	G	I	C	E	F	G	I	
ZPT25D	25	28	20	3	25	25	51	8	3.5	30	15	46	12	10

Elliptic

Model	a	b	c	d	e	Y
ZPT2004U	2	4	2.6	4.6	1.2	0.3
ZPT3507U	3.5	7	4.3	7.8	1.8	0.5
ZPT4010U	4	10	5	11	2	0.8

* Dimensions of D, E, G are the same.

Size/ $\varnothing 10, \varnothing 13, \varnothing 16$

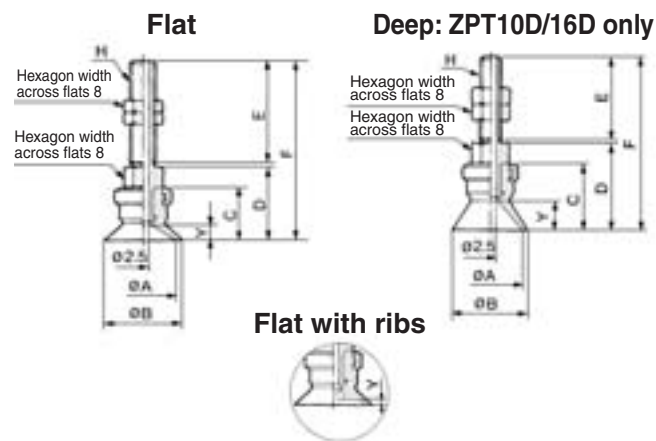

Size/ $\varnothing 40, \varnothing 50$

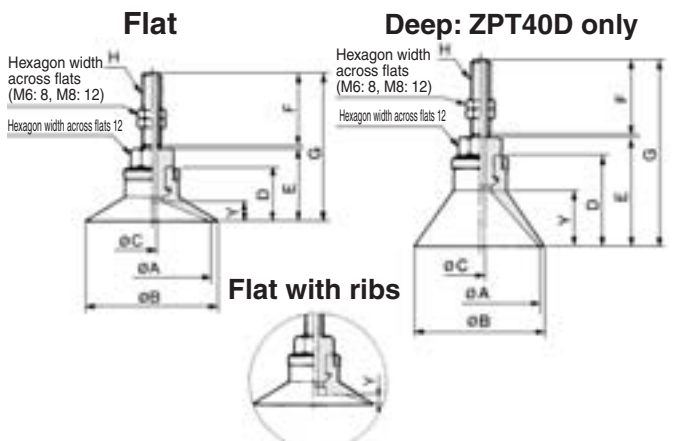

Flat/Flat with Ribs

Model	A	B	C	D	H: M5 x 0.8		H: M6 x 1		Y	
					E	F	E	F	Flat	Flat with ribs
ZPT10 ^U _C	10	12	12	17	20	38	25	43	3	1.7
ZPT13 ^U _C	13	15								1.8
ZPT16 ^U _C	16	18	12.5	17.5		38.5		43.5	3.5	1.2

Flat/Flat with Ribs

Model	A	B	D	E	H: M6 x 1			H: M8 x 1			Y	
					C	F	G	C	F	G	Flat	Flat with ribs
ZPT40 ^U _C	40	43	18.5	24.5	3	25	50.5	4.5	15	40.5	6.5	3.3
ZPT50 ^U _C	50	53	19.5	25.5			51.5			41.5	7.5	3.8

Deep

Model	A	B	C	D	H: M5 x 0.8		H: M6 x 1		Y
					E	F	E	F	
ZPT10D	10	12	15	20	20	41	25	46	6
ZPT16D	16	18	16	21	20	42	25	47	7

Deep

Model	A	B	D	E	H: M6 x 1			H: M8 x 1			Y
					C	F	G	C	F	G	
ZPT40D	40	43	29	35.5	3	25	61	4.5	15	51	17

Connection	Male thread	Pad Form	Bellows
Vacuum Entry Port	Vertical	Mounting	Use connection for vacuum entry

Size/ø6, ø8

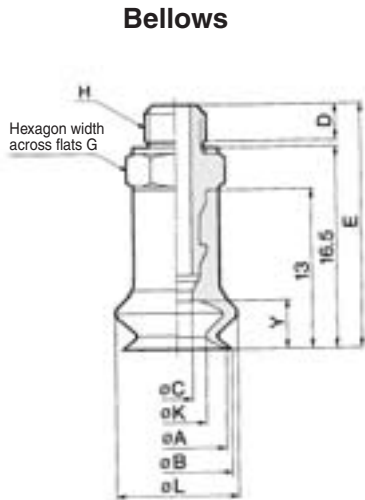

Model	A	B	C	H: M5 x 0.8			H: M6 x 1			K	L	Y
				D	E	G	D	E	G			
ZPT06B	6	7	2.5	3	20	7	4	21	8	3.3	9	4
ZPT08B	8	9		4.7	10							

Size/ø20, ø25, ø32

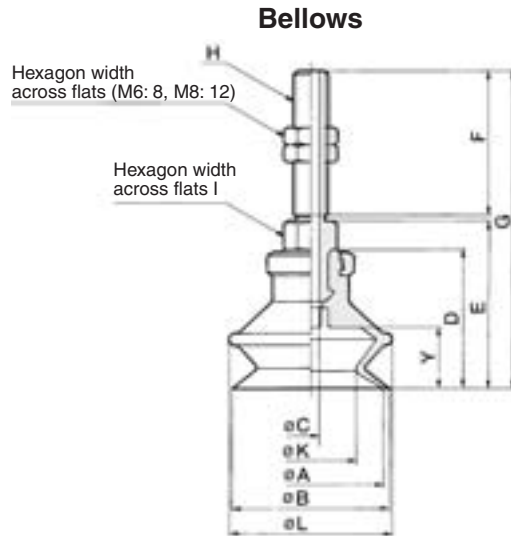

Model	A	B	D	H: M6 x 1					H: M8 x 1					K	L	Y
				C	E	F	G	I	C	E	F	G	I			
ZPT20B	20	22	23.5	3	28.5	25	54.5	8	3.5	33.5	15	49.5	12	12	25	10.5
ZPT25B	25	27	24		29	55	60		39	55	16	28		10.5		
ZPT32B	32	34	29		34	60	60		39	55	19	37		14		

Size/ø10, ø13, ø16

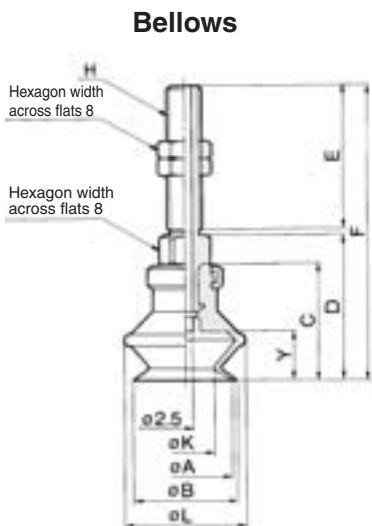

Model	A	B	C	D	H: M5 x 0.8		H: M6 x 1		K	L	Y
					E	F	E	F			
ZPT10B	10	12	16	21	20	42	25	47	6	14	5.5
ZPT13B	13	15	18.5	23.5		44.5	25	49.5	9	19	7.5
ZPT16B	16	18	20	25		46	25	51	10	21	8.5

Size/ø40, ø50

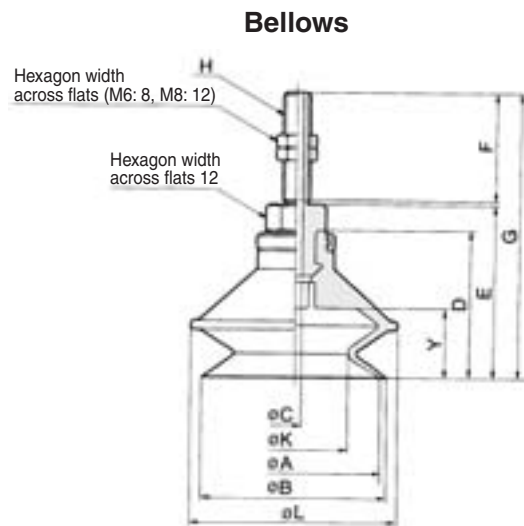

Model	A	B	D	E	H: M6 x 1			H: M8 x 1			K	L	Y
					C	F	G	C	F	G			
ZPT40B	40	43	34	40	3	25	66	4.5	15	56	24	48	16
ZPT50B	50	53	38	44			70			60	32	57	19

- ZA
- ZX
- ZR
- ZM
- ZMA
- ZQ
- ZH
- ZU
- ZL
- ZY□
- ZF□
- ZP□
- SP
- ZCUK
- AMJ
- AMV
- AEP
- HEP

Related Equipment

Series ZPT

Connection	Female thread	Pad Form	Flat/Flat with ribs/Deep
Vacuum Entry Port	Vertical	Mounting	Use connection for vacuum entry

Thin flat/Thin flat with ribs $\phi 10, \phi 13, \phi 16$ /Elliptic 2004, 3507, 4010
 Size/Flat $\phi 2, \phi 4, \phi 6, \phi 8$ Size/ $\phi 20, \phi 25, \phi 32$

Flat/Thin flat/Thin flat with ribs

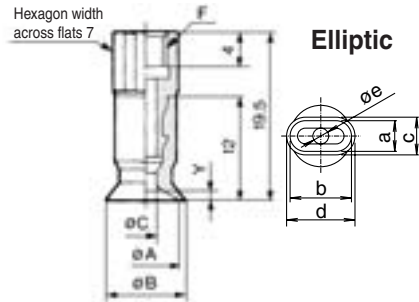

Flat

Model	A	B	C	F	Y
ZPT02U	2	2.6	1.2	M4 x 0.7	0.5
ZPT04U	4	4.8	1.6		0.8
ZPT06U	6	7	2.5		1
ZPT08U	8	9			1.5
ZPT10UT	10	11	M5 x 0.8	2.5	0.8
ZPT13UT	13	14			1
ZPT16UT	16	17			1.5
ZPT10CT	10	11			0.8
ZPT13CT	13	14	1	2.5	1
ZPT16CT	16	17			1.5

Elliptic

Model	a	b	c	d	e	Y
ZPT2004U	2	4	2.6	4.6	1.2	0.3
ZPT3507U	3.5	7	4.3	7.8	1.8	0.5
ZPT4010U	4	10	5	11	2	0.8

Size/ $\phi 10, \phi 13, \phi 16$

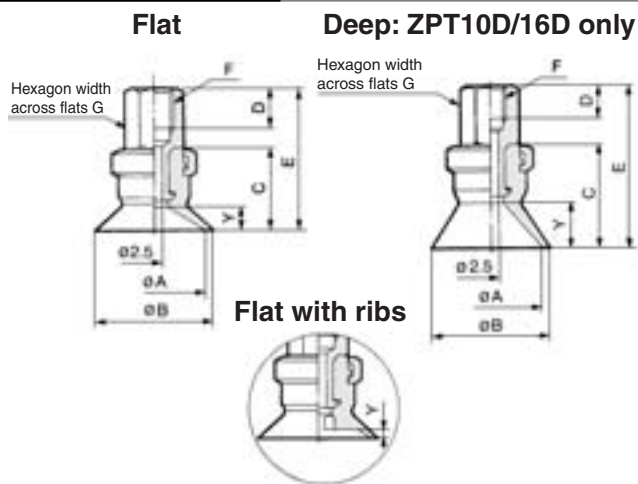

Flat/Flat with Ribs

Model	A	B	C	F: M5 x 0.8			F: M6 x 1			F: 1/8 (Rc, NPT, NPTF)		Y			
				D	E	G	D	E	G	E	G		Flat	Flat with ribs	
ZPT10 _U C	10	12	12	5	21	8	6	21	8	12	3	1.7			
ZPT13 _U C	13	15	12.5									21.5	21.5	27.5	1.8
ZPT16 _U C	16	18													3.5

Deep

Model	A	B	C	F: M5 x 0.8			F: M6 x 1			F: 1/8 (Rc, NPT, NPTF)		Y
				D	E	G	D	E	G	E	G	
ZPT10D	10	12	15	5	24	8	6	24	8	30	12	6
ZPT16D	16	18	16									25

Flat

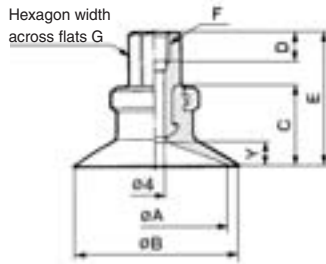

Deep: ZPT25D only

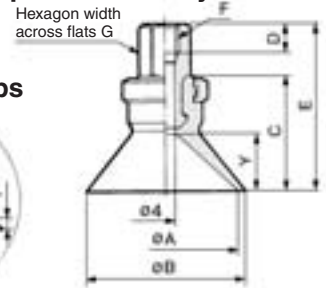

Flat with ribs

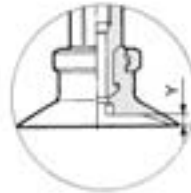

Flat/Flat with Ribs

Model	A	B	C	F: M5 x 0.8			F: M6 x 1			F: M8 x 1.25			F: 1/8 (Rc, NPT, NPTF)		Y						
				D	E	G	D	E	G	D	E	G	E	G		Flat	Flat with ribs				
ZPT20 _U C	20	23	14	5	23	8	6	23	8	8	29	12	29	12	4	1.7					
ZPT25 _U C	25	28	14.5													23.5	23.5	29.5	29.5	4.5	2.3
ZPT32 _U C	32	35																			

Deep

Model	A	B	C	F: M5 x 0.8			F: M6 x 1			F: M8 x 1.25			F: 1/8 (Rc, NPT, NPTF)		Y
				D	E	G	D	E	G	D	E	G	E	G	
ZPT25D	25	28	20	5	29	8	6	29	8	8	35	12	35	12	10

Size/ $\phi 40, \phi 50$

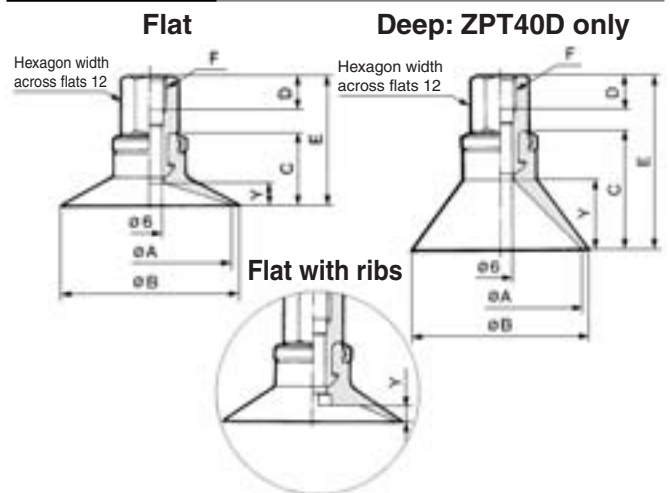

Flat/Flat with Ribs

Model	A	B	C	F: M6 x 1		F: M8 x 1.25		F: Rc 1/8		Y						
				D	E	D	E	E	Flat		Flat with ribs					
ZPT40 _U C	40	43	18.5	6	32	8	32	32	32	6.5	3.3					
ZPT50 _U C	50	53	19.5									33	33	33	7.5	3.8

Deep

Model	A	B	C	F: M6 x 1			F: M8 x 1.25		F: 1/8 (Rc, NPT, NPTF)		Y
				D	E	G	D	E	E		
ZPT40D	40	43	29	6	42.5	8	42.5	42.5	17		

Connection	Female thread	Pad Form	Bellows
Vacuum Entry Port	Vertical	Mounting	Use connection for vacuum entry

Size/ø6, ø8

Bellows

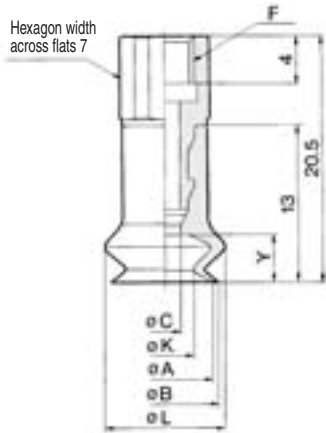

Model	A	B	C	F	K	L	Y
ZPT06B	6	7	2.5	M4 x 0.7	3.3	9	4
ZPT08B	8	9		M5 x 0.8	4.7	10	

Size/ø20, ø25, ø32

Bellows

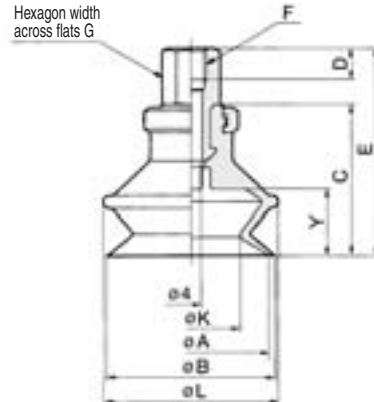

Model	A	B	C	F: M5 x 0.8			F: M6 x 1			F: M8 x 1.25			F: 1/8 (Rc, NPT, NPTF)			K	L	Y
				D	E	G	D	E	G	D	E	G	E	G				
ZPT20B	20	22	23.5		32.5			32.5			38.5			38.5		12	25	10.5
ZPT25B	25	27	24	5	33	8	6	33	8	8	39	12	39	12	16	28	10.5	
ZPT32B	32	34	29		38			38			44		44		19	37	14	

Size/ø10, ø13, ø16

Bellows

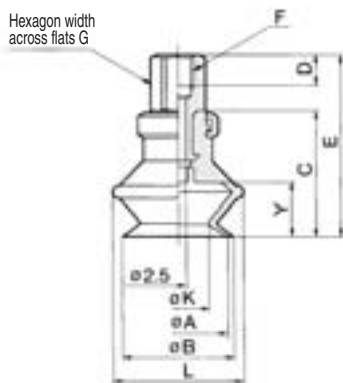

Model	A	B	C	F: M5 x 0.8			F: M6 x 1			F: 1/8 (Rc, NPT, NPTF)			K	L	Y	
				D	E	G	D	E	G	E	G					
ZPT10B	10	12	16		25			25			31			6	14	5.5
ZPT13B	13	15	18.5	5	27.5	8	6	27.5	8	33.5	12			9	19	7.5
ZPT16B	16	18	20		29			29		35				10	21	8.5

Size/ø40, ø50

Bellows

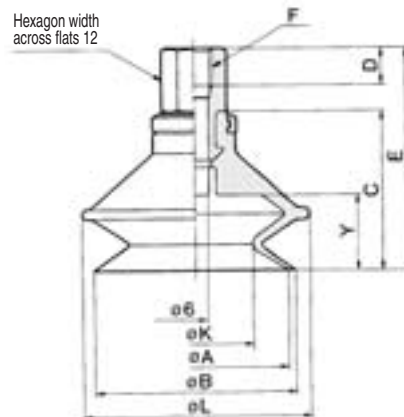

Model	A	B	C	F: M6 x 1			F: M8 x 1.25			F: 1/8 (Rc, NPT, NPTF)			K	L	Y	
				D	E		D	E		E						
ZPT40B	40	43	34		47.5		8	47.5			47.5			24	48	16
ZPT50B	50	53	38		51.5			51.5			51.5			32	57	19

- ZA
- ZX
- ZR
- ZM
- ZMA
- ZQ
- ZH
- ZU
- ZL
- ZY□
- ZF□
- ZP□
- SP
- ZCUK
- AMJ
- AMV
- AEP
- HEP

Related Equipment



Vacuum Pad/ Vertical Vacuum Entry With Buffer

Series ZPT



Specifications

Vacuum entry direction		Vertical					
Vacuum entry	Connection	Female thread		Barb fitting	One-touch fitting		
		Applicable tube dia.	ø2 to ø8 Elliptic (2 x 4, 3.5 x 7, 4 x 10) Thin section series (ø10 to ø16)		M3 x 0.5 M5 x 0.8	ø4 Nylon tube ø4 Urethane tube	ø4 tube ø6 tube
			ø10 to ø32		M5 x 0.8	ø6 Nylon tube ø6 Urethane tube	ø4 tube ø6 tube
	ø40 to ø50		M5 x 0.8 1/8 (Rc, NPT, NPTF)	ø6 Nylon tube ø6 Urethane tube	ø6 tube ø8 tube		
Connection	Thread dia.						
	ø2 to ø8	M8 x 1 Male thread					
	ø10 to ø32	M10 x 1 Male thread					
	ø40 to ø50	M14 x 1 Male thread					

Buffer Specifications

Pad dia. (mm)	ø2 to ø8*	ø10 to ø32	ø40, ø50
Stroke (mm)	6, 10, 15, 25	10, 20, 30, 40, 50	10, 20, 30, 50
Spring Reactive Force (N)	0 stroke	0.8	2.0
	Full stroke	1.2	5.0
Non-rotating specification		Rotating (J)/Non-rotating (K)	

* Refer to ø2 to ø8 for Thin flat, Thin flat with ribs and Elliptic.

Pad Type

Pad form	Flat	Flat with ribs	Deep	Bellows
Pad diameter (mm)	2, 4, 6, 8, 2 x 4, 3.5 x 7, 4 x 10, 10, 13, 16, 20, 25, 32, 40, 50	10, 13, 16, 20, 25, 32, 40, 50	10, 16, 25, 40	6, 8, 10, 13, 16, 20, 25, 32, 40, 50
Material (Color)	NBR (Black), Silicon rubber (White), Urethane rubber (Brown), Fluororubber (Black with green mark) Conductive NBR (Black with one silver mark), Conductive silicon rubber (Black with two silver marks)			
Durometer	NBR (50°), Silicon rubber (40°), Urethane rubber/Fluororubber (60°) Conductive NBR (50°), Conductive silicon rubber (50°)			

Mass

(g)

Stroke (mm)	Pad form Vacuum entry port Model	Flat/Flat with ribs							Deep					Bellows							
		Female thread		One-touch fitting			Barb fitting	Female thread		One-touch fitting		Barb fitting	Female thread		One-touch fitting		Barb fitting				
		B3	B5	□01	04	06	08	N□U□	B5	□01	04	06	08	N□U□	B3	B5	□01	04	06	08	N□U□
6	ZPT2004 3507 4010 02 to 08 Thin section series 10 to 16	22	24	—	26	27	—	22	—	—	—	—	—	—	22	24	—	26	27	—	22
	ZPT 10 to 16	—	26	—	29	30	—	25	27	—	29	30	—	25	—	27	—	30	31	—	26
10	ZPT 20 to 25	—	29	—	31	33	—	27	30	—	32	33	—	28	—	31	—	34	35	—	30
	ZPT 32	—	57	—	33	34	—	30	—	—	—	—	—	—	36	—	38	39	—	34	
10	ZPT 40	—	129	132	—	133	141	129	131	134	—	134	143	129	—	141	144	—	145	153	140
	ZPT 50	—	135	138	—	139	147	133	—	—	—	—	—	—	—	148	151	—	152	160	147

Mass by Stroke

(g)

Stroke (mm)	10	15	20	25	30	40	50
ZPT2004 3507 4010 ZPT02 to 08 Thin section series 10 to 16	+6	+7	—	+8	—	—	—
ZPT10 to 25	—	—	+11	—	+13	+23	+24
ZPT40, 50	—	—	+38	—	+40	—	+67

How to Order

Series ZPT With buffer

ZPT 16 U GS K 20 - 06 - A10

Pad diameter (mm)

2004	2 x 4
3507	3.5 x 7
4010	4 x 10
02	2
04	4
06	6
08	8
10	10
13	13
16	16
20	20
25	25
32	32
40	40
50	50

Mounting thread diameter/ Male thread
(Refer to "Table (3)" for applications.)

Vacuum entry port
(Refer to "Table (3)" for applications.)

Buffer stroke
(Refer to "Table (2)" for applications.)

Buffer type

J	Rotating
K	Non-rotating

Material

N	NBR
S	Silicon rubber
U	Urethane rubber
F	Fluororubber
GN	Conductive NBR
GS	Conductive silicon rubber

Pad type
(“Table (1)” for applications.)

U	Flat
C	Flat with ribs
D	Deep
B	Bellows
UT	Thin flat
CT	Thin flat with ribs

Table (1) Pad Diameter/Pad Type

Type	Diameter (mm)														
	2 x 4	3.5 x 7	4 x 10	2	4	6	8	10	13	16	20	25	32	40	50
Flat	●	●	●	●	●	●	●	●	●	●	●	●	●	●	●
Flat with ribs	—	—	—	—	—	—	—	●	●	●	●	●	●	●	●
Deep	—	—	—	—	—	—	—	●	—	●	—	●	—	●	—
Bellows	—	—	—	—	—	●	●	●	●	●	●	●	●	●	●
Thin flat	—	—	—	—	—	—	—	●	●	●	—	—	—	—	—
Thin flat with ribs	—	—	—	—	—	—	—	●	●	●	—	—	—	—	—

Table (2) Pad Diameter/Stroke

Stroke (mm)	Diameter (mm)																	
	2 x 4	3.5 x 7	4 x 10	2	4	6	8	Thin flat/Thin flat with ribs			10	13	16	20	25	32	40	50
6 mm	●	●	●	●	●	●	●	●	●	●	—	—	—	—	—	—	—	—
10 mm	●	●	●	●	●	●	●	●	●	●	●	●	●	●	●	●	●	●
15 mm	●	●	●	●	●	●	●	●	●	●	—	—	—	—	—	—	—	—
20 mm	—	—	—	—	—	—	—	—	—	—	●	●	●	●	●	●	●	●
25 mm	●	●	●	●	●	●	●	●	●	●	—	—	—	—	—	—	—	—
30 mm	—	—	—	—	—	—	—	—	—	—	●	●	●	●	●	●	●	●
40 mm	—	—	—	—	—	—	—	—	—	—	●	●	●	●	●	●	—	—
50 mm	—	—	—	—	—	—	—	—	—	—	●	●	●	●	●	●	●	●

Table (3) Vacuum Entry/Mounting Thread Diameter

	Symbol	Thread dia./Port size	ø2 to ø8	ø10 to ø32	ø40, ø50	
			2 x 4, 3.5 x 7, 4 x 10 Thin section series ø10 to ø16			
Vacuum entry	Female thread	B3	M3 x 0.5	●	—	
		B5	M5 x 0.8	●	●	
		B01	Rc 1/8	—	—	●
		N01	NPT 1/8	—	—	●
		T01	NPTF 1/8	—	—	●
	Barb fitting	N4	ø4 Nylon tube	●	—	—
		N6	ø6 Nylon tube	—	●	●
		U4	ø4 Urethane tube	●	—	—
		U6	ø6 Urethane tube	—	●	●
		One-touch fitting	04	ø4 tube	●	●
06	ø6 tube		●	●	●	
08	ø8 tube		—	—	●	
Mounting	Male thread	A8	M8 x 1	●	—	
		A10	M10 x 1	—	●	—
		A14	M14 x 1	—	—	●

Tightening Torque

Mounting thread diameter	Torque (N·m)
M8 x 1	2.0 ±0.5
M10 x 1	3.0 ±0.5
M14 x 1	7.0 ±0.5

ZA
ZX
ZR
ZM
ZMA
ZQ
ZH
ZU
ZL
ZY□
ZF□
ZP□
SP
ZCUK
AMJ
AMV
AEP
HEP
Related Equipment

Series ZPT

Connection	Female thread (Buffer)	Pad Form	Flat/Thin flat/Thin flat with ribs/Elliptic
Vacuum Entry Port	Vertical	Mounting	Buffer body

Flat/ø2, ø4, ø6, ø8, Thin flat/Thin flat with ribs/ø10, ø13, ø16, Elliptic/2004, 3507, 4010

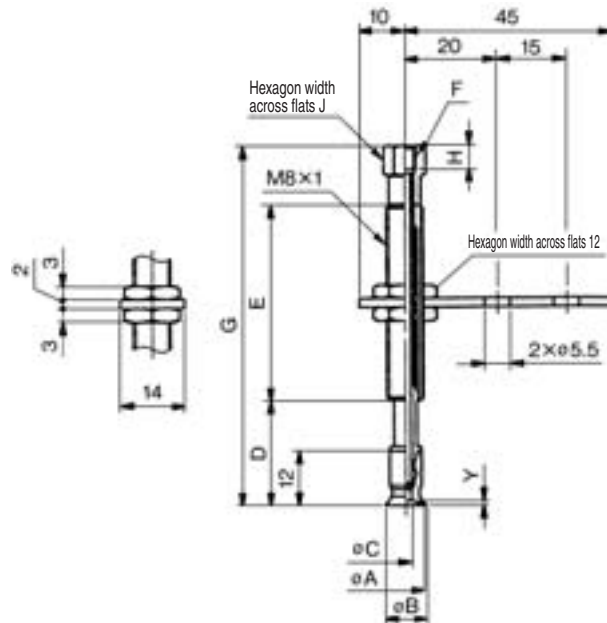

Elliptic

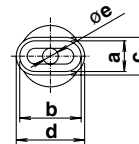

Flat

Model	A	B	C	Y
ZPT02U□□□□□-B□-A8	2	2.6	1.2	0.5
ZPT04U□□□□□-B□-A8	4	4.8	1.6	0.8
ZPT06U□□□□□-B□-A8	6	7	2.5	
ZPT08U□□□□□-B□-A8	8	9		1

Elliptic

Model	a	b	c	d	e	Y
ZPT2004U	2	4	2.6	4.6	1.2	0.3
ZPT3507U	3.5	7	4.3	7.8	1.8	0.5
ZPT4010U	4	10	5	11	2	0.8

Thin Flat/Thin Flat with Ribs

Model	A	B	C	Y
ZPT10UT	10	11	2.5	1
ZPT13UT	13	14		1.5
ZPT16UT	16	17		0.8
ZPT10CT	10	11		1
ZPT13CT	13	14		
ZPT16CT	16	17		

Dimensions by Stroke

Model	D	E	F: M3 x 0.5			F: M5 x 0.8		
			G	H	J	G	H	J
ZPT□□□□□ 6-B□-A8	18	15	44	3	6	46	5	8
ZPT□□□□□ 10-B□-A8	23	43	77			79		
ZPT□□□□□ 15-B□-A8	28	82	84					
ZPT□□□□□ 25-B□-A8	38	92	94					

Connection	Female thread (Buffer)	Pad Form	Flat/Flat with ribs/Deep
Vacuum Entry Port	Vertical	Mounting	Buffer body

Flat/Flat with ribs/ø10, ø13, ø16

Deep/ø10, ø16

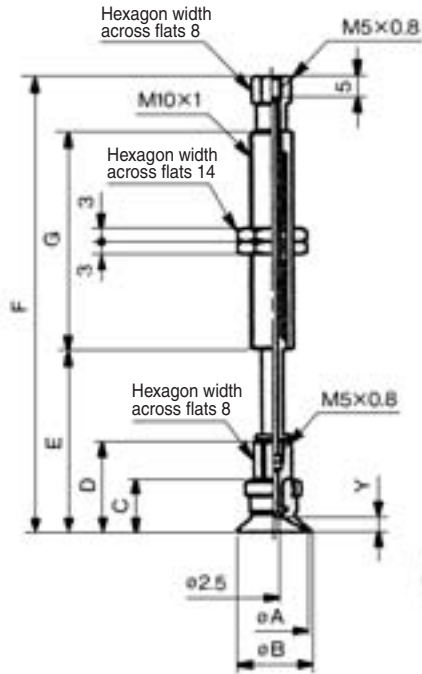

Flat with ribs

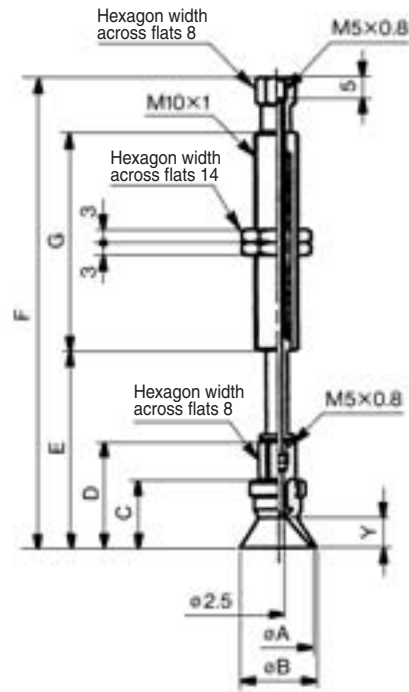

ø10, ø13, ø16

Flat/Flat with Ribs

Model	A	B	C	D	Y	
					Flat	Flat with ribs
ZPT10 ^U _C □□□□□-B5-A10	10	12	12	21	3	1.7
ZPT13 ^U _C □□□□□-B5-A10	13	15				1.8
ZPT16 ^U _C □□□□□-B5-A10	16	18	12.5	21.5	3.5	1.2

Dimensions by Stroke

Model	ø10, ø13		ø16		G
	E	F	E	F	
ZPT□□ ^U _C □□□□10-B5-A10	32.5	68.5	33	69	23
ZPT□□ ^U _C □□□□20-B5-A10	42.5	106.5	43	107	51
ZPT□□ ^U _C □□□□30-B5-A10	52.5	116.5	53	117	
ZPT□□ ^U _C □□□□40-B5-A10	62.5	152.5	63	153	77
ZPT□□ ^U _C □□□□50-B5-A10	72.5	162.5	73	163	

ø10, ø16

Deep

Model	A	B	C	D	Y
ZPT10D□□□□□-B5-A10	10	12	15	24	6
ZPT16D□□□□□-B5-A10	16	18	16	25	7

Dimensions by Stroke

Model	ø10		ø16		G
	E	F	E	F	
ZPT□□D□□□□10-B5-A10	35.5	71.5	36.5	72.5	23
ZPT□□D□□□□20-B5-A10	45.5	109.5	46.5	110.5	51
ZPT□□D□□□□30-B5-A10	55.5	119.5	56.5	120.5	
ZPT□□D□□□□40-B5-A10	65.5	155.5	66.5	156.5	77
ZPT□□D□□□□50-B5-A10	75.5	165.5	76.5	166.5	

- ZA
- ZX
- ZR
- ZM
- ZMA
- ZQ
- ZH
- ZU
- ZL
- ZY□
- ZF□
- ZP□
- SP
- ZCUK
- AMJ
- AMV
- AEP
- HEP
- Related Equipment

Series ZPT

Connection	Female thread (Buffer)	Pad Form	Flat/Flat with ribs/Deep
Vacuum Entry Port	Vertical	Mounting	Buffer body

Flat/Flat with ribs/ø20, ø25, ø32

Deep/ø25

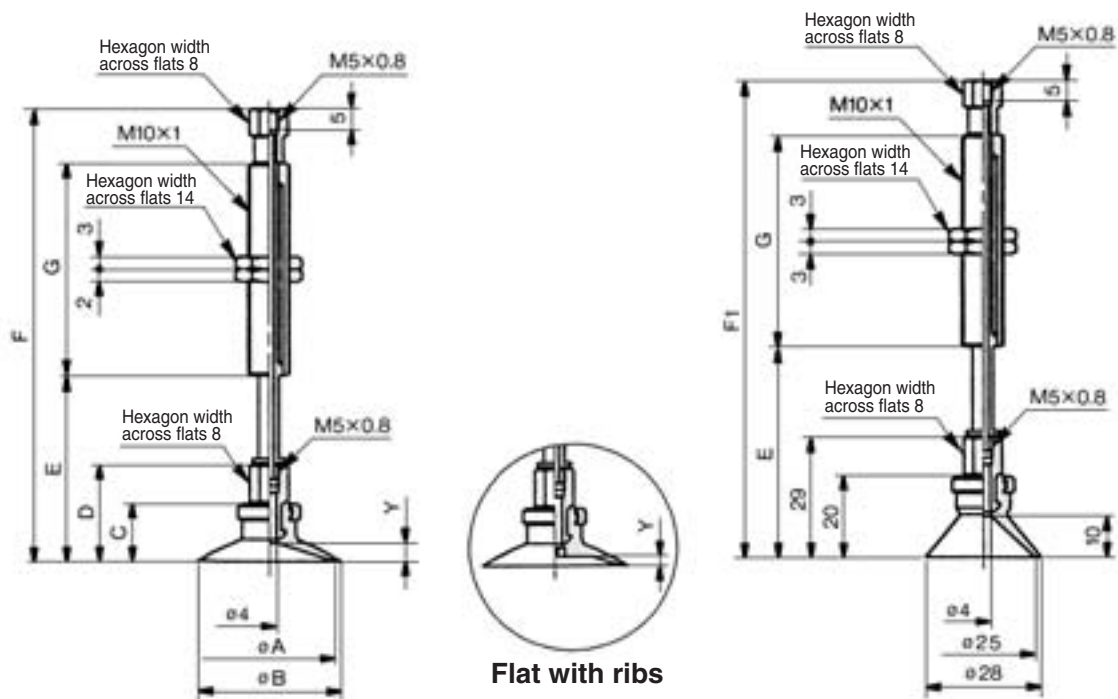

ø20, ø25, ø32

Flat/Flat with Ribs

Model	A	B	C	D	Y	
					Flat	Flat with ribs
ZPT20 ^U _C □□□□□-B5-A10	20	23	14	23	4	1.7
ZPT25 ^U _C □□□□□-B5-A10	25	28				1.8
ZPT32 ^U _C □□□□□-B5-A10	32	35	14.5	23.5	4.5	2.3

Dimensions by Stroke

Model	ø20, ø25		ø32		G
	E	F	E	F	
ZPT□□ ^U _C □□□□□10-B5-A10	34.5	70.5	35	71	23
ZPT□□ ^U _C □□□□□20-B5-A10	44.5	108.5	45	109	51
ZPT□□ ^U _C □□□□□30-B5-A10	54.5	118.5	55	119	
ZPT□□ ^U _C □□□□□40-B5-A10	64.5	154.5	65	155	77
ZPT□□ ^U _C □□□□□50-B5-A10	74.5	164.5	75	165	

ø25

Deep

Model	E	F	G
ZPT25D□□□□10-B5-A10	40.5	76.5	23
ZPT25D□□□□20-B5-A10	50.5	114.5	51
ZPT25D□□□□30-B5-A10	60.5	124.5	
ZPT25D□□□□40-B5-A10	70.5	160.5	77
ZPT25D□□□□50-B5-A10	80.5	170.5	

Connection	Female thread (Buffer)	Pad Form	Bellows
Vacuum Entry Port	Vertical	Mounting	Buffer body

Bellows/ø20, ø25, ø32

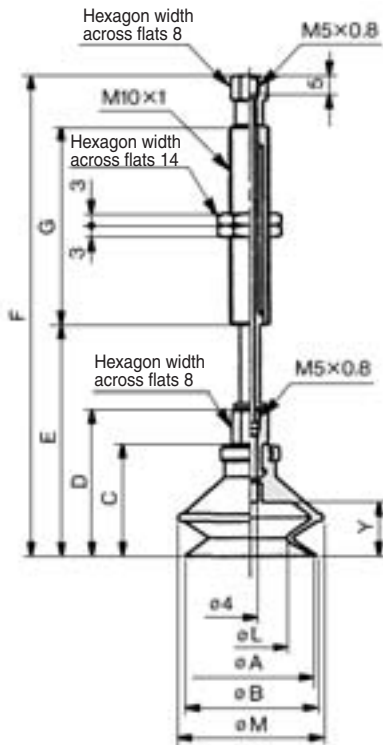

ø20, ø25, ø32

Bellows

Model	A	B	C	D	L	M	Y
ZPT□□□□□□□□-B5-A10	20	22	23.5	32.5	12	25	10.5
ZPT25B□□□□□□□□-B5-A10	25	27	24	33	16	28	
ZPT32B□□□□□□□□-B5-A10	32	34	29	38	19	37	

Dimensions by Stroke

Model	ø20		ø25		ø32		G
	E	F	E	F	E	F	
ZPT□□B□□□□□10-B5-A10	44	80	44.5	80.5	49.5	85.5	23
ZPT□□B□□□□□20-B5-A10	54	118	54.5	118.5	59.5	123.5	51
ZPT□□B□□□□□30-B5-A10	64	128	64.5	128.5	69.5	133.5	
ZPT□□B□□□□□40-B5-A10	74	164	74.5	164.5	79.5	169.5	77
ZPT□□B□□□□□50-B5-A10	84	174	84.5	174.5	89.5	179.5	

Bellows/ø40, ø50

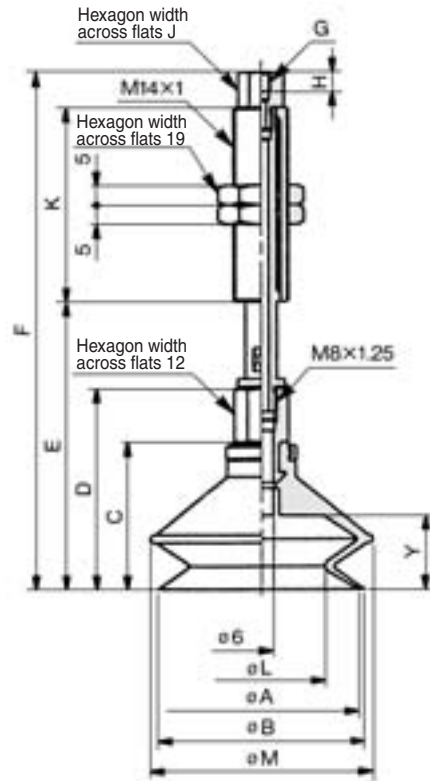

ø40, ø50

Bellows

Model	A	B	C	D	L	M	Y
ZPT40B□□□□□□□□-□□□□-A14	40	43	34	47.5	24	48	16
ZPT50B□□□□□□□□-□□□□-A14	50	53	38	51.5	32	57	19

Dimensions by Stroke

Model	E		G: M5 x 0.8				G: 1/8 (Rc, NPT, NPTF)				K
	ø40	ø50	F		H	J	F		J		
			ø40	ø50			ø40	ø50			
ZPT□□B□□□□□10-□□□□-A14	60	64	125	129	5	10	126.5	130.5	13	50	
ZPT□□B□□□□□20-□□□□-A14	70	74	129	133			132	136			
ZPT□□B□□□□□30-□□□□-A14	80	84	139	143			142	146			
ZPT□□B□□□□□50-□□□□-A14	100	104	184	188			187	191		75	

- ZA
- ZX
- ZR
- ZM
- ZMA
- ZQ
- ZH
- ZU
- ZL
- ZY□
- ZF□
- ZP□
- SP
- ZCUK
- AMJ
- AMV
- AEP
- HEP

Related Equipment

Series ZPT

Connection	One-touch fitting (Buffer)	Pad Form	Flat/Flat with ribs/Deep/Thin flat Thin flat with ribs/Elliptic
Vacuum Entry Port	Vertical	Mounting	Buffer body

Flat/ø2, ø4, ø6, ø8, Thin flat/Flat with ribs/ø10, ø13, ø16, Elliptic/2004, 3507, 4010

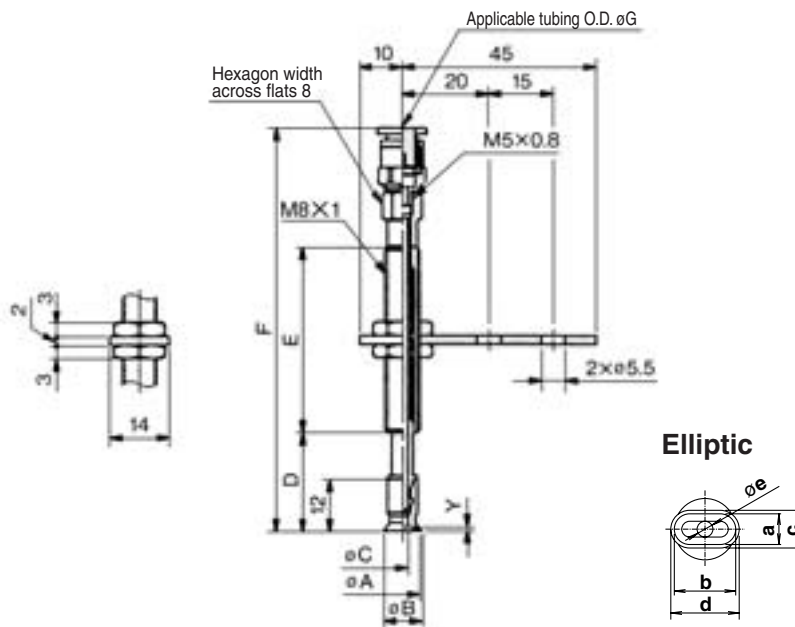

Flat

Model	A	B	C	Y
ZPT02U□□□□□□-0□-A8	2	2.6	1.2	0.5
ZPT04U□□□□□□-0□-A8	4	4.8	1.6	0.8
ZPT06U□□□□□□-0□-A8	6	7	2.5	
ZPT08U□□□□□□-0□-A8	8	9		1

Elliptic

Model	a	b	c	d	øe	Y
ZPT2004U	2	4	2.6	4.6	1.2	0.3
ZPT3507U	3.5	7	4.3	7.8	1.8	0.5
ZPT4010U	4	10	5	11	2	0.8

Thin Flat/Thin Flat with Ribs

Model	A	B	C	Y
ZPT10UT	10	11	2.5	1
ZPT13UT	13	14		1.5
ZPT16UT	16	17		0.8
ZPT10CT	10	11		1
ZPT13CT	13	14		
ZPT16CT	16	17		

Dimensions by Stroke

Model	D	E	F	
			G: 4	G: 6
ZPT□□□□□□ 6-0□-A8	18	15	60	61
ZPT□□□□□□ 10-0□-A8	23	43	93	94
ZPT□□□□□□ 15-0□-A8	28		98	99
ZPT□□□□□□ 25-0□-A8	38		108	109

Connection	One-touch fitting (Buffer)	Pad Form	Flat/Flat with ribs/Deep
Vacuum Entry Port	Vertical	Mounting	Buffer body

Flat/Flat with ribs/ø10, ø13, ø16

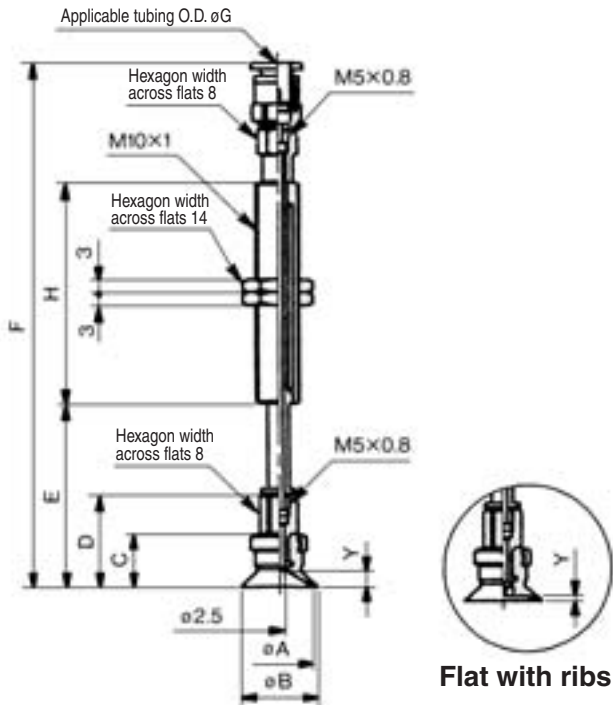

Deep/ø10, ø16

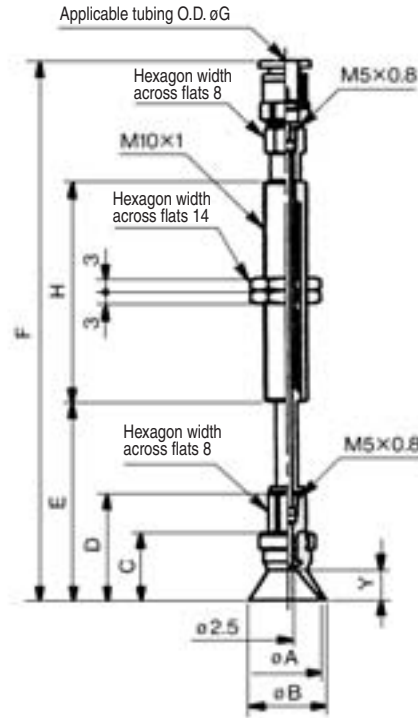

ø10, ø13, ø16

Flat/Flat with Ribs

Model	A	B	C	D	Y	
					Flat	Flat with ribs
ZPT10 _C □□□□□-0□-A10	10	12	12	21	3	1.7
ZPT13 _C □□□□□-0□-A10	13	15	12	21	3	1.8
ZPT16 _C □□□□□-0□-A10	16	18	12.5	21.5	3.5	1.2

Dimensions by Stroke

Model	ø10, ø13			ø16			H
	E	F		E	F		
		G: 4	G: 6		G: 4	G: 6	
ZPT□□ _C □□□□10-0□-A10	32.5	82.5	83.5	33	83	84	23
ZPT□□ _C □□□□20-0□-A10	42.5	120.5	121.5	43	121	122	51
ZPT□□ _C □□□□30-0□-A10	52.5	130.5	131.5	53	131	132	51
ZPT□□ _C □□□□40-0□-A10	62.5	166.5	167.5	63	167	168	77
ZPT□□ _C □□□□50-0□-A10	72.5	176.5	177.5	73	177	178	77

ø10, ø16

Deep

Model	A	B	C	D	Y
ZPT10D□□□□□-0□-A10	10	12	15	24	6
ZPT16D□□□□□-0□-A10	16	18	16	25	7

Dimensions by Stroke

Model	ø10			ø16			H
	E	F		E	F		
		G: 4	G: 6		G: 4	G: 6	
ZPT□□D□□□□10-0□-A10	35.5	85.5	86.5	36.5	86.5	87.5	23
ZPT□□D□□□□20-0□-A10	45.5	123.5	124.5	46.5	124.5	125.5	51
ZPT□□D□□□□30-0□-A10	55.5	133.5	134.5	56.5	134.5	135.5	51
ZPT□□D□□□□40-0□-A10	65.5	169.5	170.5	66.5	170.5	171.5	77
ZPT□□D□□□□50-0□-A10	75.5	179.5	180.5	76.5	180.5	181.5	77

- ZA
- ZX
- ZR
- ZM
- ZMA
- ZQ
- ZH
- ZU
- ZL
- ZY□
- ZF□
- ZP□
- SP
- ZCUK
- AMJ
- AMV
- AEP
- HEP

Related Equipment

Series ZPT

Connection	One-touch fitting (Buffer)	Pad Form	Flat/Flat with ribs/Deep
Vacuum Entry Port	Vertical	Mounting	Buffer body

Flat/Flat with ribs/ø20, ø25, ø32

Deep/ø25

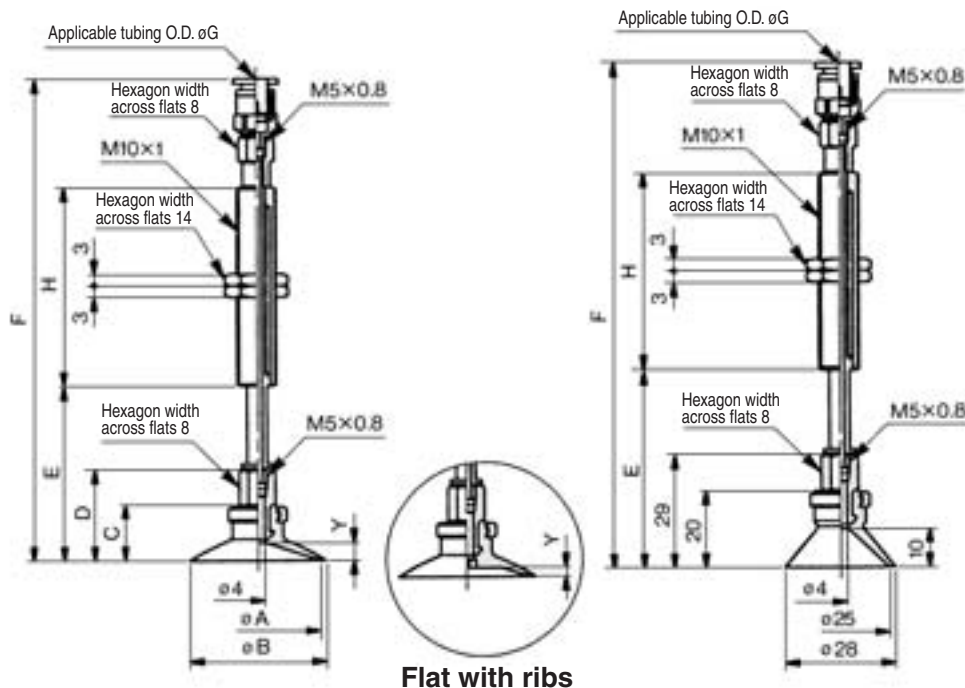

ø20, ø25, ø32

Flat Type/Flat with Ribs

Model	A	B	C	D	Y	
					Flat	Flat with ribs
ZPT20 _U □□□□□-0□-A10	20	23	14	23	4	1.7
ZPT25 _U □□□□□-0□-A10	25	28	14	23	4	1.8
ZPT32 _U □□□□□-0□-A10	32	35	14.5	23.5	4.5	2.3

Dimensions by Stroke

Model	ø20, ø25			ø32			H
	E	F		E	F		
		G: 4	G: 6		G: 4	G: 6	
ZPT□□ _U □□□□□10-0□-A10	34.5	84.5	85.5	35	85	86	23
ZPT□□ _U □□□□□20-0□-A10	44.5	122.5	123.5	45	123	124	51
ZPT□□ _U □□□□□30-0□-A10	54.5	132.5	133.5	55	133	134	77
ZPT□□ _U □□□□□40-0□-A10	64.5	168.5	169.5	65	169	170	
ZPT□□ _U □□□□□50-0□-A10	74.5	178.5	179.5	75	179	180	

ø25

Deep

Model	E	F		H
		G: 4	G: 6	
ZPT25D□□□□10-0□-A10	40.5	90.5	91.5	23
ZPT25D□□□□20-0□-A10	50.5	128.5	129.5	51
ZPT25D□□□□30-0□-A10	60.5	138.5	139.5	77
ZPT25D□□□□40-0□-A10	70.5	174.5	175.5	
ZPT25D□□□□50-0□-A10	80.5	184.5	185.5	

Connection	One-touch fitting (Buffer)	Pad Form	Flat/Flat with ribs/Deep
Vacuum Entry Port	Vertical	Mounting	Buffer body

Flat/Flat with ribs/ø40, ø50

Deep/ø40

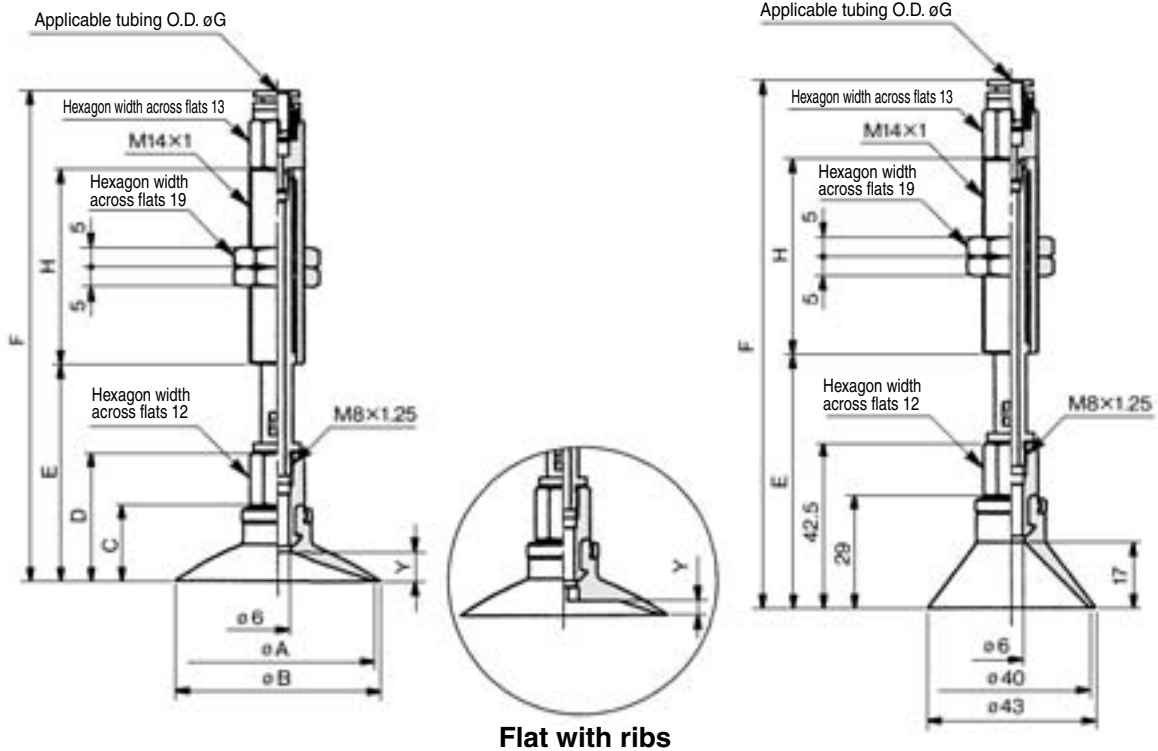

Flat with ribs

ø40, ø50

Flat/Flat with Ribs

Model	A	B	C	D	Y	
					Flat	Flat with ribs
ZPT40 _C □□□□□-0□-A14	40	43	18.5	32	6.5	3.3
ZPT50 _C □□□□□-0□-A14	50	53	19.5	33	7.5	3.8

Dimensions by Stroke

Model	ø40			ø50			H
	E	F		E	F		
		G: 6	G: 8		G: 6	G: 8	
ZPT□□ _C □□□□□10-0□-A14	44.5	129.5	135	45.5	130.5	136	50
ZPT□□ _C □□□□□20-0□-A14	54.5	124.4	129.4	55.5	125.4	130.4	
ZPT□□ _C □□□□□30-0□-A14	64.5	134.4	139.4	65.5	135.4	140.4	
ZPT□□ _C □□□□□50-0□-A14	84.5	179.4	184.4	85.5	180.4	185.4	

ø40

Deep

Model	E	F		H
		G: 6	G: 8	
ZPT40D□□□□10-0□-A14	55	140	145.5	50
ZPT40D□□□□20-0□-A14	65	134.9	139.9	
ZPT40D□□□□30-0□-A14	75	144.9	149.9	
ZPT40D□□□□50-0□-A14	95	189.9	194.9	

- ZA
- ZX
- ZR
- ZM
- ZMA
- ZQ
- ZH
- ZU
- ZL
- ZY□
- ZF□
- ZP□
- SP
- ZCUK
- AMJ
- AMV
- AEP
- HEP
- Related Equipment

Series ZPT

Connection	One-touch fitting (Buffer)	Pad Form	Bellows
Vacuum Entry Port	Vertical	Mounting	Buffer body

Bellows/ $\phi 6, \phi 8$

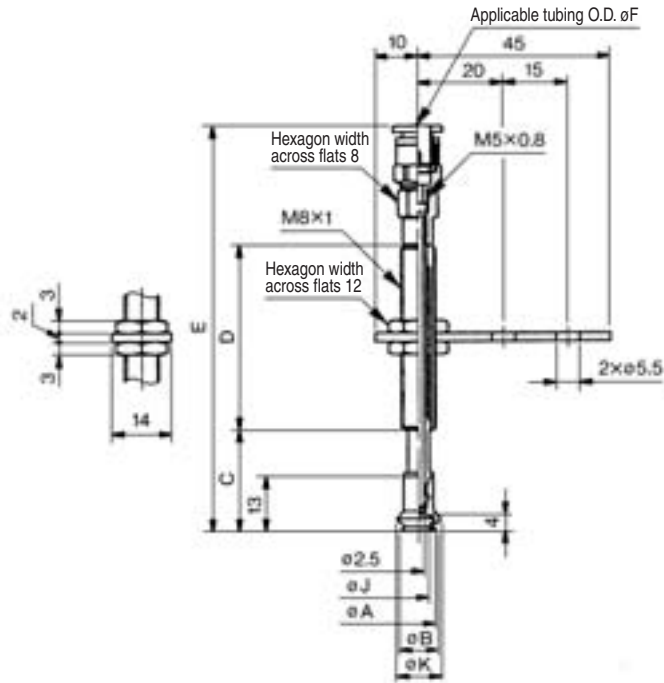

$\phi 6, \phi 8$

Bellows

Model	A	B	J	K
ZPT06B□□□□□-0□-A8	6	7	3.3	9
ZPT08B□□□□□-0□-A8	8	9	4.7	10

Dimensions by Stroke

Model	C	D	E	
			F: 4	F: 6
ZPT□□B□□□□ 6-0□-A8	19	15	61	62
ZPT□□B□□□□ 10-0□-A8	24	43	94	95
ZPT□□B□□□□ 15-0□-A8	29		99	100
ZPT□□B□□□□ 25-0□-A8	39		109	110

Bellows/ $\phi 10, \phi 13, \phi 16$

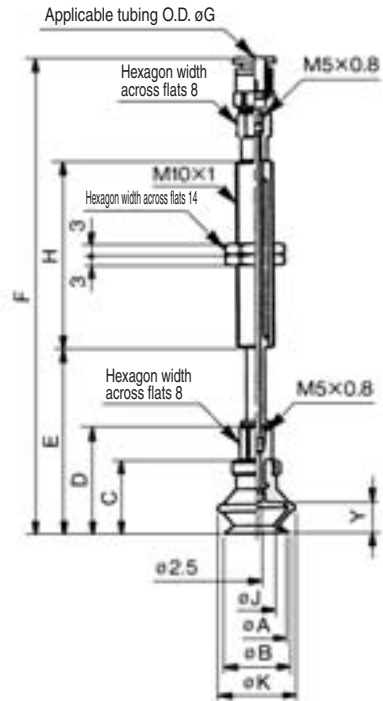

$\phi 10, \phi 13, \phi 16$

Bellows

Model	A	B	C	D	J	K	Y
ZPT10B□□□□□-0□-A10	10	12	16	25	6	14	5.5
ZPT13B□□□□□-0□-A10	13	15	18.5	27.5	9	19	7.5
ZPT16B□□□□□-0□-A10	16	18	20	29	10	21	8.5

Dimensions by Stroke

Model	$\phi 10$		$\phi 13$		$\phi 16$			H		
	E	F	E	F	E	F				
		G: 4		G: 6		G: 4	G: 6			
ZPT□□B□□□□ 10-0□-A10	36.5	86.5	87.5	39	89	90	40.5	90.5	91.5	23
ZPT□□B□□□□ 20-0□-A10	46.5	124.5	125.5	49	127	128	50.5	128.5	129.5	51
ZPT□□B□□□□ 30-0□-A10	56.5	134.5	135.5	59	137	138	60.5	138.5	139.5	
ZPT□□B□□□□ 40-0□-A10	66.5	170.5	171.5	69	173	174	70.5	174.5	185.5	77
ZPT□□B□□□□ 50-0□-A10	76.5	180.5	181.5	79	183	184	80.5	184.5	185.5	

Connection	One-touch fitting (Buffer)	Pad Form	Bellows
Vacuum Entry Port	Vertical	Mounting	Buffer body

Bellows/ø20, ø25, ø32

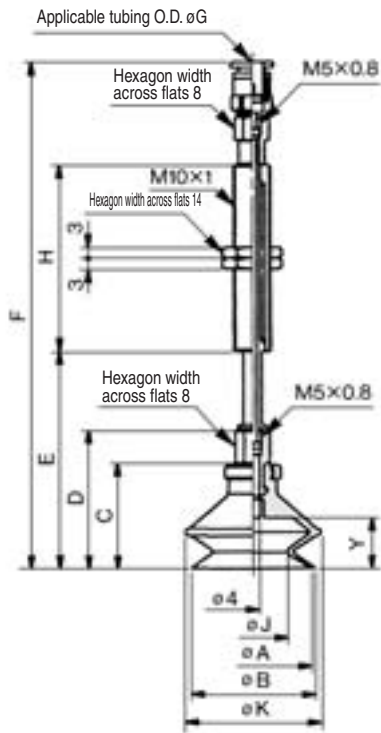

ø20, ø25, ø32

Bellows

Model	A	B	C	D	J	K	Y
ZPT20B□□□□□-0□-A10	20	22	23.5	32.5	12	25	10.5
ZPT25B□□□□□-0□-A10	25	27	24	33	16	28	
ZPT32B□□□□□-0□-A10	32	34	29	38	19	37	

Dimensions by Stroke

Model	ø20		ø25		ø32		H
	E	F	E	F	E	F	
		G: 4 G: 6		G: 4 G: 6		G: 4 G: 6	
ZPT□□B□□□□10-0□-A10	44	94 95	44.5 94.5	95.5	49.5	99.5 100.5	23
ZPT□□B□□□□20-0□-A10	54	132 133	54.5 132.5	133.5	59.5	137.5 138.5	51
ZPT□□B□□□□30-0□-A10	64	142 143	64.5 142.5	143.5	69.5	147.5 148.5	
ZPT□□B□□□□40-0□-A10	74	178 179	74.5 178.5	179.5	79.5	183.5 184.5	77
ZPT□□B□□□□50-0□-A10	84	188 189	84.5 188.5	189.5	89.5	193.5 194.5	

Bellows/ø40, ø50

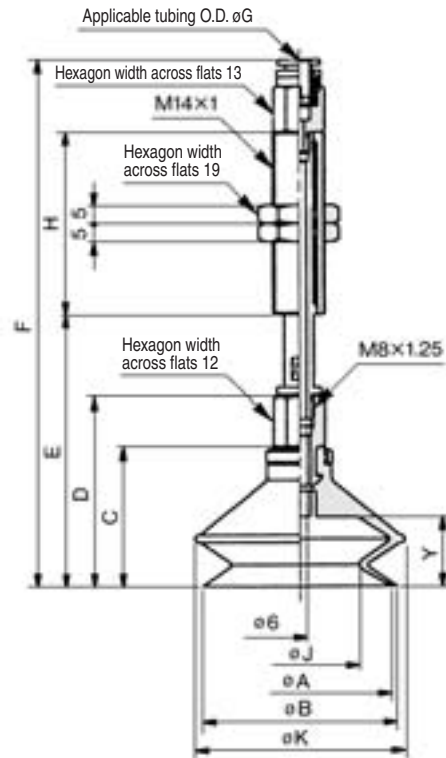

ø40, ø50

Bellows

Model	A	B	C	D	J	K	Y
ZPT40B□□□□□-0□-A14	40	43	34	47.5	24	48	16
ZPT50B□□□□□-0□-A14	50	53	38	51.5	32	57	19

Dimensions by Stroke

Model	ø40		ø50		H
	E	F	E	F	
		G: 6 G: 8		G: 6 G: 8	
ZPT□□B□□□□10-0□-A14	60	145 150.5	64	149 154.5	50
ZPT□□B□□□□20-0□-A14	70	139.9 144.9	74	143.9 148.9	
ZPT□□B□□□□30-0□-A14	80	149.9 154.9	84	153.9 158.9	
ZPT□□B□□□□50-0□-A14	100	194.9 199.9	104	198.9 203.9	

- ZA
- ZX
- ZR
- ZM
- ZMA
- ZQ
- ZH
- ZU
- ZL
- ZY□
- ZF□
- ZP□
- SP
- ZCUK
- AMJ
- AMV
- AEP
- HEP

Related Equipment

Series ZPT

Connection	Barb fitting (Buffer)	Pad Form	Flat/Thin flat/Thin flat with ribs/Elliptic
Vacuum Entry Port	Vertical	Mounting	Buffer body

Flat/ $\varnothing 2, \varnothing 4, \varnothing 6, \varnothing 8$, Thin flat/Thin flat with ribs/ $\varnothing 10, \varnothing 13, \varnothing 16$, Elliptic/2004, 3507, 4010

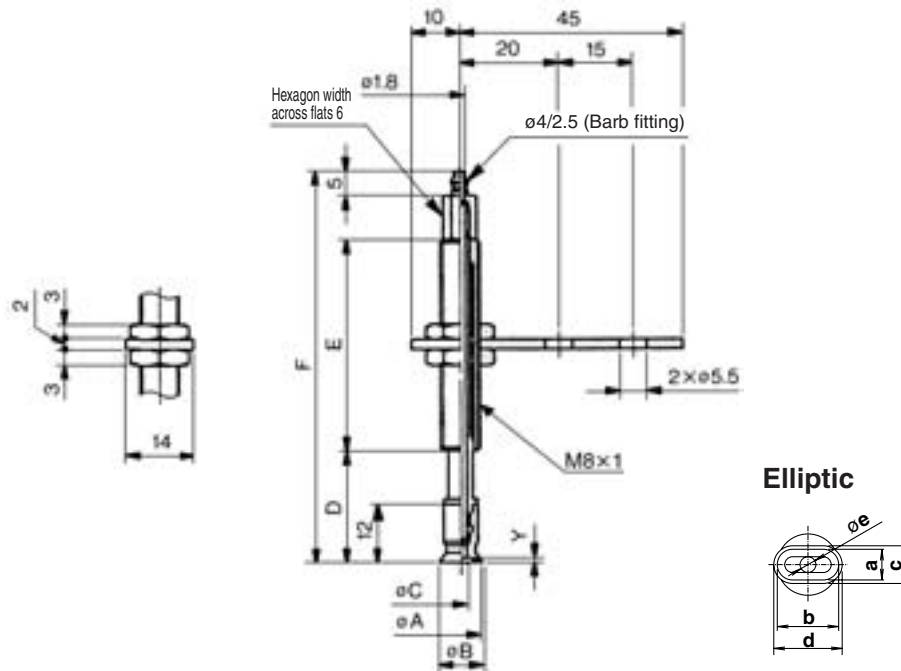

Flat

Model	A	B	C	Y
ZPT02U□□□□□□□□-□4-A8	2	2.6	1.2	0.5
ZPT04U□□□□□□□□-□4-A8	4	4.8	1.6	0.8
ZPT06U□□□□□□□□-□4-A8	6	7	2.5	
ZPT08U□□□□□□□□-□4-A8	8	9		1

Dimensions by Stroke

Model	D	E	F
ZPT□□□□□□□□ 6-□4-A8	18	15	47
ZPT□□□□□□□□10-□4-A8	23		80
ZPT□□□□□□□□15-□4-A8	28	43	85
ZPT□□□□□□□□25-□4-A8	38		95

Elliptic

Model	a	b	c	d	e	Y
ZPT2004U	2	4	2.6	4.6	1.2	0.3
ZPT3507U	3.5	7	4.3	7.8	1.8	0.5
ZPT4010U	4	10	5	11	2	0.8

Thin Flat/Thin Flat with Ribs

Model	A	B	C	Y
ZPT10UT□□	10	11	2.5	1
ZPT13UT□□	13	14		1.5
ZPT16UT□□	16	17		0.8
ZPT10CT□□	10	11		1
ZPT13CT□□	13	14		
ZPT16CT□□	16	17		

Connection	Barb fitting (Buffer)	Pad Form	Flat/Flat with ribs/Deep
Vacuum Entry Port	Vertical	Mounting	Buffer body

Flat/Flat with ribs/ø10, ø13, ø16

Deep/ø10, ø16

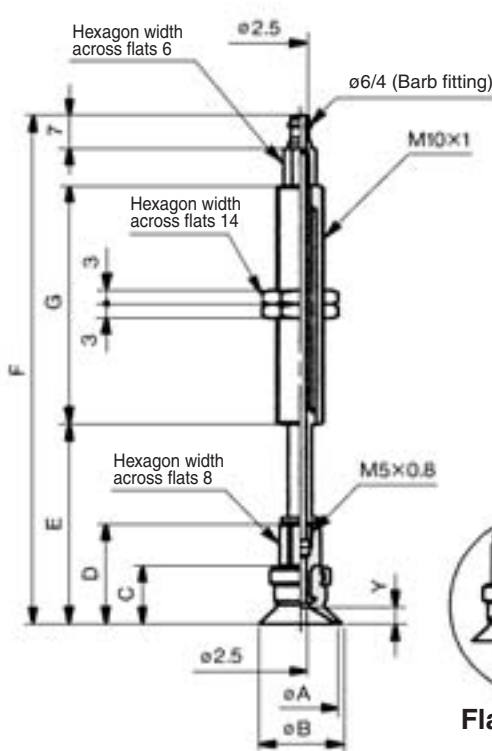

Flat with ribs

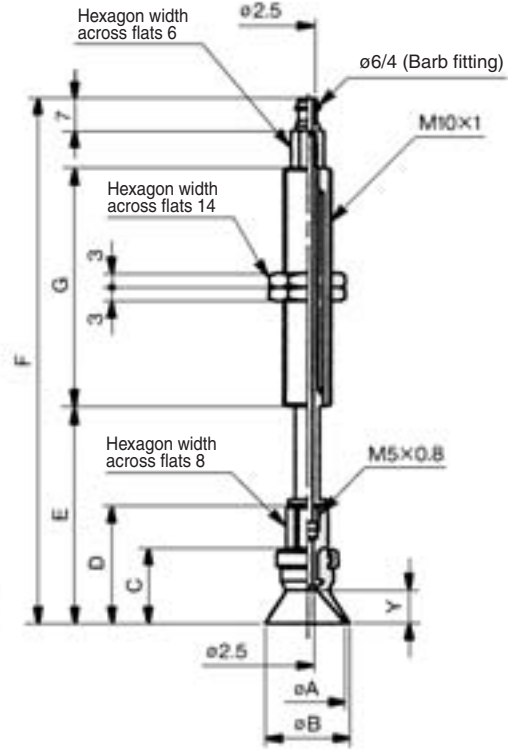

ø10, ø13, ø16

Flat/Flat with Ribs

Model	A	B	C	D	Y	
					Flat	Flat with ribs
ZPT10 _C □□□□□□□□□□-□6-A10	10	12	12	21	3	1.7
ZPT13 _C □□□□□□□□□□-□6-A10	13	15				1.8
ZPT16 _C □□□□□□□□□□-□6-A10	16	18	12.5	21.5	3.5	1.2

Dimensions by Stroke

Model	ø10, ø13		ø16		G
	E	F	E	F	
ZPT□□ _C □□□□□□□□□□10-□6-A10	32.5	70.5	33	71	23
ZPT□□ _C □□□□□□□□□□20-□6-A10	42.5	108.5	43	109	51
ZPT□□ _C □□□□□□□□□□30-□6-A10	52.5	118.5	53	119	
ZPT□□ _C □□□□□□□□□□40-□6-A10	62.5	154.5	63	155	77
ZPT□□ _C □□□□□□□□□□50-□6-A10	72.5	164.5	73	165	

ø10, ø16

Deep

Model	A	B	C	D	Y
ZPT10D□□□□□□□□□□-□6-A10	10	12	15	24	6
ZPT16D□□□□□□□□□□-□6-A10	16	18	16	25	7

Dimensions by Stroke

Model	ø10		ø16		G
	E	F	E	F	
ZPT□□D□□□□□□□□□□10-□6-A10	35.5	73.5	36.5	74.5	23
ZPT□□D□□□□□□□□□□20-□6-A10	45.5	111.5	46.5	112.5	51
ZPT□□D□□□□□□□□□□30-□6-A10	55.5	121.5	56.5	122.5	
ZPT□□D□□□□□□□□□□40-□6-A10	65.5	157.7	66.5	158.5	77
ZPT□□D□□□□□□□□□□50-□6-A10	75.5	167.5	76.5	168.5	

- ZA
- ZX
- ZR
- ZM
- ZMA
- ZQ
- ZH
- ZU
- ZL
- ZY□
- ZF□
- ZP□
- SP
- ZCUK
- AMJ
- AMV
- AEP
- HEP
- Related Equipment

Series ZPT

Connection	Barb fitting (Buffer)	Pad Form	Flat/Flat with ribs/Deep
Vacuum Entry Port	Vertical	Mounting	Buffer body

Flat/Flat with ribs/ø20, ø25, ø32

Deep/ø25

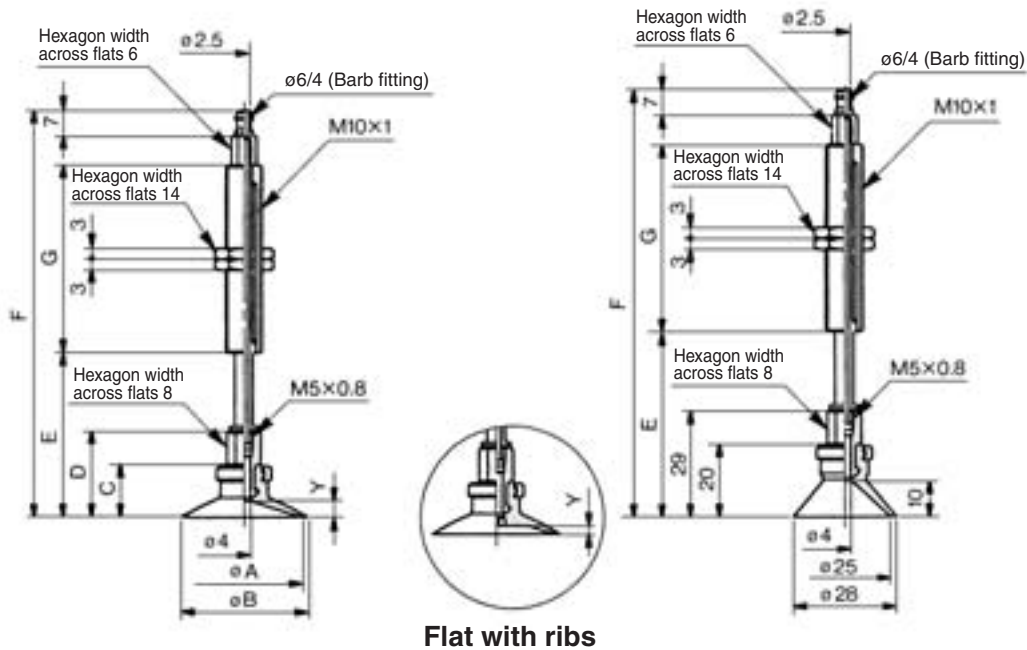

Flat with ribs

ø20, ø25, ø32

Flat/Flat with Ribs

Model	A	B	C	D	Y	
					Flat	Flat with ribs
ZPT20 _C □□□□□□□□□□6-A10	20	23	14	23	4	1.7
ZPT25 _C □□□□□□□□□□6-A10	25	28				1.8
ZPT32 _C □□□□□□□□□□6-A10	32	35	14.5	23.5	4.5	2.3

Dimensions by Stroke

Model	ø20, ø25		ø32		G
	E	F	E	F	
ZPT□□ _C □□□□□□□□□□10-□□6-A10	34.5	72.5	35	73	23
ZPT□□ _C □□□□□□□□□□20-□□6-A10	44.5	110.5	45	111	51
ZPT□□ _C □□□□□□□□□□30-□□6-A10	54.5	120.5	55	121	
ZPT□□ _C □□□□□□□□□□40-□□6-A10	64.5	156.5	65	157	77
ZPT□□ _C □□□□□□□□□□50-□□6-A10	74.5	166.5	75	167	

ø25

Deep

Model	E	F	G
ZPT25D□□□□□□□□□□10-□□6-A10	40.5	78.5	23
ZPT25D□□□□□□□□□□20-□□6-A10	50.5	116.5	51
ZPT25D□□□□□□□□□□30-□□6-A10	60.5	126.5	
ZPT25D□□□□□□□□□□40-□□6-A10	70.5	162.5	77
ZPT25D□□□□□□□□□□50-□□6-A10	80.5	172.5	

Connection	Barb fitting (Buffer)	Pad Form	Flat/Flat with ribs/Deep
Vacuum Entry Port	Vertical	Mounting	Buffer body

Flat/Flat with ribs/∅40, ∅50

Deep/∅40

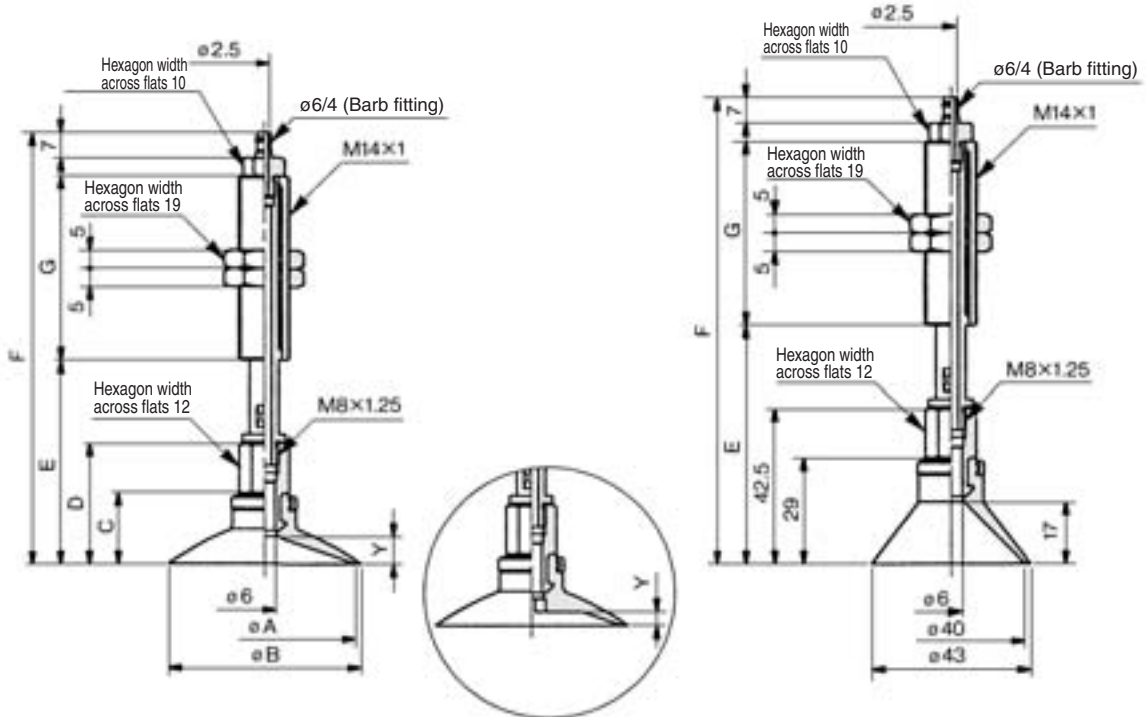

Flat with ribs

∅40, ∅50

Flat/Flat with Ribs

Model	A	B	C	D	Y	
					Flat	Flat with ribs
ZPT40 _C □□□□□□□□□□6-A14	40	43	18.5	32	6.5	3.3
ZPT50 _C □□□□□□□□□□6-A14	50	53	19.5	33	7.5	3.8

Dimensions by Stroke

Model	∅40		∅50		G
	E	F	E	F	
ZPT□□□□□□□□□□10-□□6-A14	44.5	113.5	45.5	114.5	50
ZPT□□□□□□□□□□20-□□6-A14	54.5	116.5	55.5	117.5	
ZPT□□□□□□□□□□30-□□6-A14	64.5	126.5	65.5	127.5	
ZPT□□□□□□□□□□50-□□6-A14	84.5	171.5	85.5	172.5	

∅40

Deep

Model	E	F	G
ZPT40D□□□□10-□□6-A14	55	124	50
ZPT40D□□□□20-□□6-A14	65	127	
ZPT40D□□□□30-□□6-A14	75	137	75
ZPT40D□□□□50-□□6-A14	95	182	

- ZA
- ZX
- ZR
- ZM
- ZMA
- ZQ
- ZH
- ZU
- ZL
- ZY□
- ZF□
- ZP□
- SP
- ZCUK
- AMJ
- AMV
- AEP
- HEP
- Related Equipment

Series ZPT

Connection	Barb fitting (Buffer)	Pad Form	Bellows
Vacuum Entry Port	Vertical	Mounting	Buffer body

Bellows/ø6, ø8

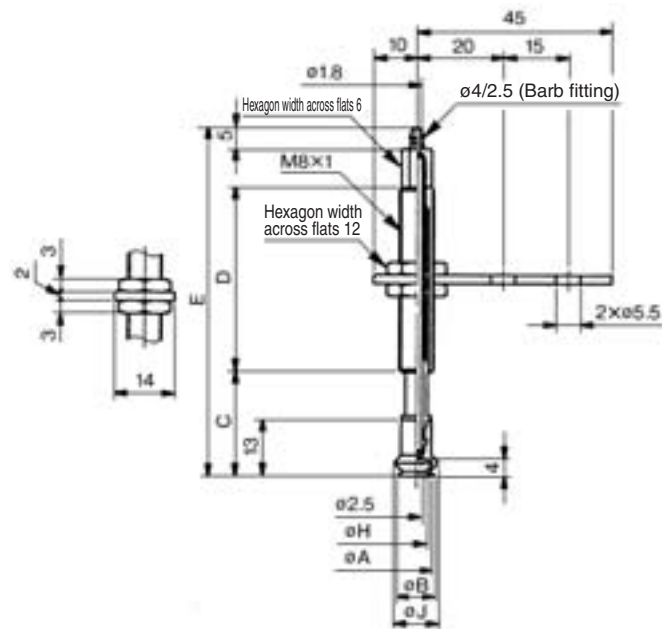

Bellows/ø10, ø13, ø16

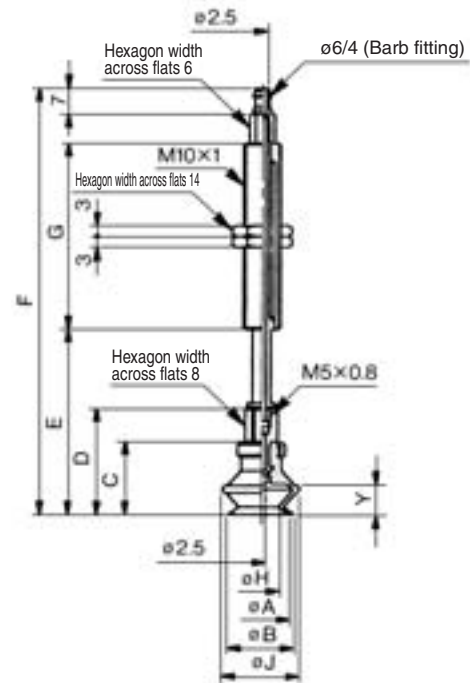

ø6, ø8

Bellows

Model	A	B	H	J
ZPT06B□□□□□□□□□□4-A8	6	7	3.3	9
ZPT08B□□□□□□□□□□4-A8	8	9	4.7	10

Dimensions by Stroke

Model	C	D	E
ZPT□□B□□□□□6□4-A8	19	15	48
ZPT□□B□□□□□10□4-A8	24	43	81
ZPT□□B□□□□□15□4-A8	29		86
ZPT□□B□□□□□25□4-A8	39		96

ø10, ø13, ø16

Bellows

Model	A	B	C	D	H	J	Y
ZPT10B□□□□□□□□□□6-A10	10	12	16	25	6	14	5.5
ZPT13B□□□□□□□□□□6-A10	13	15	18.5	27.5	9	19	7.5
ZPT16B□□□□□□□□□□6-A10	16	18	20	29	10	21	8.5

Dimensions by Stroke

Model	ø10		ø13		ø16		G
	E	F	E	F	E	F	
ZPT□□B□□□□□10□6-A10	36.5	74.5	39	77	40.5	78.5	23
ZPT□□B□□□□□20□6-A10	46.5	112.5	49	115	50.5	116.5	51
ZPT□□B□□□□□30□6-A10	56.5	122.5	59	125	60.5	126.5	
ZPT□□B□□□□□40□6-A10	66.5	158.5	69	161	70.5	162.5	77
ZPT□□B□□□□□50□6-A10	76.5	168.5	79	171	80.5	172.5	

Connection	Barb fitting (Buffer)	Pad Form	Bellows
Vacuum Entry Port	Vertical	Mounting	Buffer body

Bellows/ø20, ø25, ø32

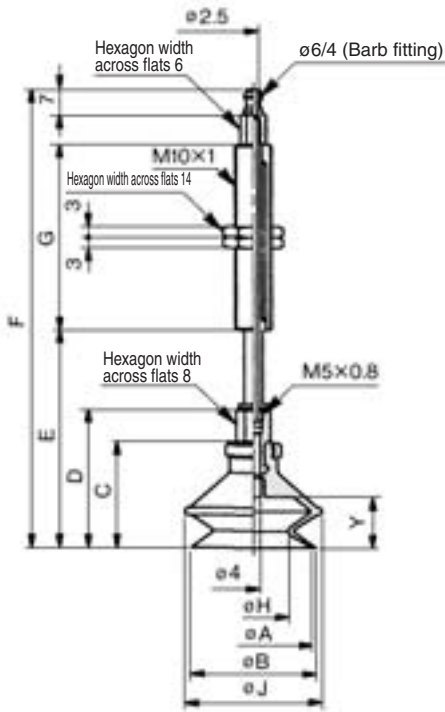

ø20, ø25, ø32

Bellows

Model	A	B	C	D	H	J	Y
ZPT20B□□□□□□□□□□-□6-A10	20	22	23.5	32.5	12	25	10.5
ZPT25B□□□□□□□□□□-□6-A10	25	27	24	33	16	28	
ZPT32B□□□□□□□□□□-□6-A10	32	34	29	38	19	37	

Dimensions by Stroke

Model	ø20		ø25		ø32		G
	E	F	E	F	E	F	
ZPT□□B□□□□□10-□6-A10	44	82	44.5	82.5	49.5	87.5	23
ZPT□□B□□□□□20-□6-A10	54	120	54.5	120.5	59.5	125.5	51
ZPT□□B□□□□□30-□6-A10	64	130	64.5	130.5	69.5	135.5	
ZPT□□B□□□□□40-□6-A10	74	166	74.5	166.5	79.5	171.5	77
ZPT□□B□□□□□50-□6-A10	84	176	84.5	176.5	89.5	181.5	

Bellows/ø40, ø50

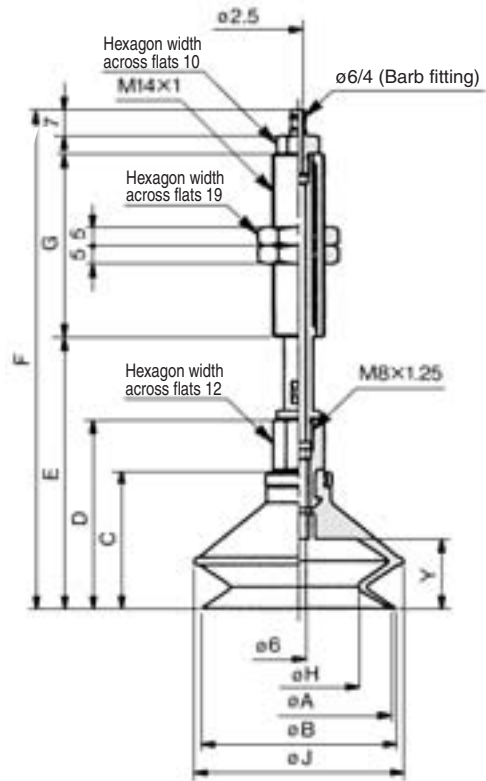

ø40, ø50

Bellows

Model	A	B	C	D	H	J	Y
ZPT40B□□□□□□□□□□-□6-A14	40	43	34	47.5	24	48	16
ZPT50B□□□□□□□□□□-□6-A14	50	53	38	51.5	32	57	19

Dimensions by Stroke

Model	ø40		ø50		G
	E	F	E	F	
ZPT□□B□□□□□10-□6-A14	60	129	64	133	50
ZPT□□B□□□□□20-□6-A14	70	132	74	136	
ZPT□□B□□□□□30-□6-A14	80	142	84	146	
ZPT□□B□□□□□50-□6-A14	100	187	104	191	

- ZA
- ZX
- ZR
- ZM
- ZMA
- ZQ
- ZH
- ZU
- ZL
- ZY□
- ZF□
- ZP□
- SP
- ZCUK
- AMJ
- AMV
- AEP
- HEP

Related Equipment



Vacuum Pad/ Lateral Vacuum Entry with One-touch Fitting Without Buffer

Series ZPR



Specifications

Vacuum entry	Direction		Lateral	
	Connection		One-touch fitting	
Applicable tube dia.	Elliptic (2 x 4, 3.5 x 7, 4 x 10) Thin section series (ø10 to ø16) ø2 to ø8		ø4, ø6 tube	
	ø10 to ø16		ø4, ø6 tube	
	ø20 to ø32		ø4, ø6, ø8 tube	
	ø40 to ø50		ø6, ø8 tube	
Mounting	Connection		Male thread	Female thread
	Thread dia.	Elliptic (2 x 4, 3.5 x 7, 4 x 10) Thin section series (ø10 to ø16) ø2 to ø8	M5 x 0.8, M6 x 1	M4 x 0.7, M5 x 0.8
		ø10 to ø16	M5 x 0.8, M6 x 1	M5 x 0.8, M6 x 1
		ø20 to ø32	M6 x 1, M8 x 1	M5 x 0.8, M6 x 1, M8 x 1.25
		ø40 to ø50	M6 x 1, M8 x 1	M6 x 1, M8 x 1.25

Pad Type

Pad form	Flat	Flat with ribs	Deep	Bellows	Thin flat/Thin flat with ribs
Pad diameter (mm)	2, 4, 6, 8, 2 x 4, 3.5 x 7, 4 x 10, 10, 13, 16, 20 25, 32, 40, 50	10, 13, 16, 20, 25, 32, 40, 50	10, 16, 25, 40	6, 8, 10, 13, 16, 20, 25, 32, 40, 50	10, 13, 16
Material (Color)	NBR (Black), Silicon rubber (White), Urethane rubber (Brown), Fluororubber (Black with green mark) Conductive NBR (Black with one silver mark), Conductive silicon rubber (Black with two silver marks)				
Durometer	NBR (50°), Silicon rubber (40°), Urethane rubber/Fluororubber (60°) Conductive NBR (50°), Conductive silicon rubber (50°)				

Mass/Male Thread (Female thread)

(g)

Model	Pad form		Flat				Flat with ribs			Deep			Bellows			
	Connection	M4	M5	M6	M8	M5	M6	M8	M5	M6	M8	M4	M5	M6	M8	
ZPR02 to 08 2004, 3507, 4010 Thin section series 10 to 16	— (19)	26 (20)	27 (—)	—	—	—	—	—	—	—	—	(19) (Except ø2, ø4)	26 (20) (Except ø2, ø4)	27 (—) (Except ø2, ø4)	—	
ZPR10	—	29 (23)	31 (21)	—	29 (23)	31 (22)	—	29 (23)	30 (22)	—	—	—	29 (23)	31 (22)	—	
ZPR13	—	—	—	—	—	—	—	—	—	—	—	—	—	—	—	
ZPR16	—	—	—	—	—	—	—	—	31 (23)	31 (22)	—	—	—	—	—	
ZPR20	—	—	—	—	—	—	—	—	—	—	—	—	—	—	—	
ZPR25	—	— (51)	57 (50)	61 (48)	— (51)	57 (50)	61 (48)	— (51)	65 (50)	68 (48)	—	— (51)	57 (50)	61 (48)	—	
ZPR32	—	—	—	—	—	—	—	—	—	—	—	—	—	—	—	
ZPR40	—	—	64 (56)	67 (54)	—	64 (56)	67 (54)	—	65 (57)	68 (55)	—	—	64 (56)	67 (54)	—	
ZPR50	—	—	66 (58)	69 (56)	—	67 (59)	70 (57)	—	—	—	—	—	66 (58)	69 (56)	—	

(): Figures for female thread connections.

How to Order

Series ZPR
Without buffer

ZPR 02 U N - 04 - A5

Pad dia. Pad type Material Vacuum entry port Mounting thread

Pad diameter (mm)

2004	2 x 4
3507	3.5 x 7
4010	4 x 10
02	2
04	4
06	6
08	8
10	10
13	13
16	16
20	20
25	25
32	32
40	40
50	50

Pad type



(Refer to "Table (1)" for applications.)

U	Flat
C	Flat with ribs
D	Deep
B	Bellows
UT	Thin flat
CT	Thin flat with ribs

Mounting thread



(Refer to "Table (2)" for applications.)

Vacuum entry port



(Refer to "Table (2)" for applications.)

Table (2) Vacuum Entry/Mounting Thread Diameter

Connection	Symbol	Thread dia./ Port size	ø2 to ø8 2 x 4 3.5 x 7 4 x 10 ø10 to ø16 (Thin section series)	ø10 to ø16	ø20 to ø32	ø40 to ø50
Mounting	Male thread	04	ø4 tube	●	●	—
		06	ø6 tube	●	●	●
		08	ø8 tube	—	—	●
		A5	M5 x 0.8	●	●	—
	Female thread	A6	M6 x 1	●	●	●
		A8	M8 x 1	—	—	●
		B4	M4 x 0.7	●	—	—
		B5	M5 x 0.8	●	●	—
	B6	M6 x 1	—	●	●	
	B8	M8 x 1.25	—	—	●	

Material

N	NBR
S	Silicon rubber
U	Urethane rubber
F	Fluororubber
GN	Conductive NBR
GS	Conductive silicon rubber

Table (1) Pad Diameter/Pad Type

Type	Dia. (mm)														
	2 x 4	3.5 x 7	4 x 10	2	4	6	8	10	13	16	20	25	32	40	50
Flat	●	●	●	●	●	●	●	●	●	●	●	●	●	●	●
Flat with ribs	—	—	—	—	—	—	—	●	●	●	●	●	●	●	●
Deep	—	—	—	—	—	—	—	●	●	●	●	●	●	●	—
Bellows	—	—	—	—	—	●	●	●	●	●	●	●	●	●	●
Thin flat	—	—	—	—	—	—	—	●	●	●	—	—	—	—	—
Thin flat with ribs	—	—	—	—	—	—	—	●	●	●	—	—	—	—	—

- ZA
- ZX
- ZR
- ZM
- ZMA
- ZQ
- ZH
- ZU
- ZL
- ZY□
- ZF□
- ZP□
- SP
- ZCUK
- AMJ
- AMV
- AEP
- HEP
- Related Equipment

Series ZPR

Connection	One-touch fitting	Pad Form	Flat/Flat with ribs/Deep/Thin flat/Thin flat with ribs/Elliptic
Vacuum Entry Port	Lateral	Mounting	Male thread

Size/Flat $\phi 2, \phi 4, \phi 6, \phi 8$ /Thin flat/Thin flat with ribs $\phi 10, \phi 13, \phi 16$ /Elliptic 2004, 3507, 4010

Flat/Thin flat/Thin flat with ribs

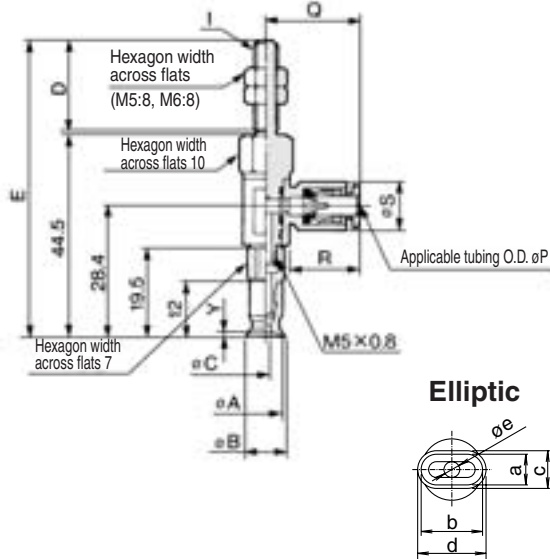

Size/ $\phi 10, \phi 13, \phi 16$

Flat

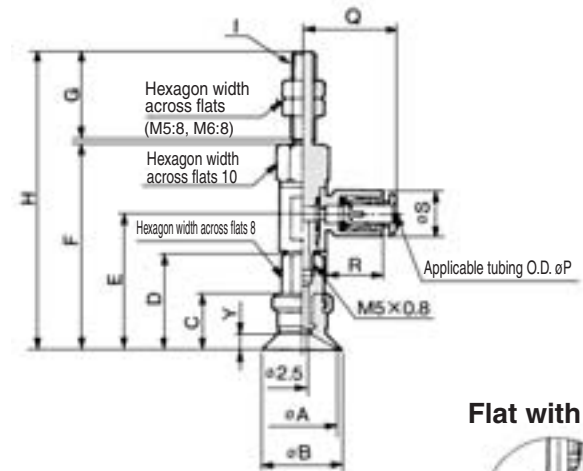

Flat with ribs

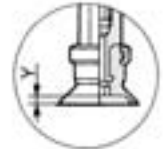

Deep: ZPR10D, 16D only

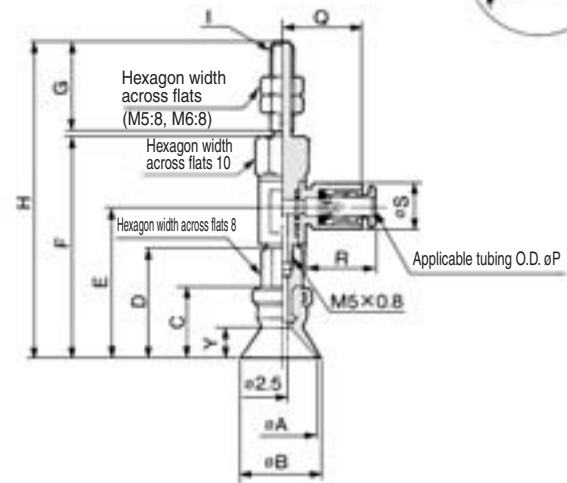

Flat

Model	A	B	C	I: M5 x 0.8		I: M6 x 1		Y
				D	E	D	E	
ZPR02U	2	2.6	1.2	20	65.5	25	70.5	0.5
ZPR04U	4	4.8	1.6					0.8
ZPR06U	6	7	2.5					0.8
ZPR08U	8	9	2.5					1

Applicable Tubing

Applicable tubing O. D.	P	Q	R	S
$\phi 4$	4	20.6	15.6	10.4
$\phi 6$	6	21.6	16.6	12.8

Elliptic

Model	a	b	c	d	e	Y
ZPR2004U	2	4	2.6	4.6	1.2	0.3
ZPR3507U	3.5	7	4.3	7.8	1.8	0.5
ZPR4010U	4	10	5	11	2	0.8

* Dimensions of D, E are the same.

Thin Flat/Thin Flat with Ribs

Model	A	B	Y
ZPR10UT	10	11	1
ZPR13UT	13	14	1.5
ZPR16UT	16	17	
ZPR10CT	10	11	0.8
ZPR13CT	13	14	1
ZPR16CT	16	17	

* Dimensions of D, E are the same.

Flat/Flat with Ribs

Model	A	B	C	D	E	F	I: M5 x 0.8		I: M6 x 1		Y	
							G	H	G	H	Flat	Flat with ribs
ZPR10 ^U _C	10	12	12	21	29.9	46	20	67	25	72	3	1.7
ZPR13 ^U _C	13	15										1.8
ZPR16 ^U _C	16	18	12.5	21.5	30.4	46.5	20	67.5	25	72.5	3.5	1.2

Deep

Model	A	B	C	D	E	F	I: M5 x 0.8		I: M6 x 1		Y
							G	H	G	H	
ZPR10D	10	12	15	24	32.9	49	20	70	25	75	6
ZPR16D	16	18	16	25	33.9	50	20	71	25	76	7

Applicable Tubing

Applicable tubing O.D.	P	Q	R	S
$\phi 4$	4	20.6	15.6	10.4
$\phi 6$	6	21.6	16.6	12.8

Vacuum Pad/
Lateral Vacuum Entry with One-touch Fitting without Buffer **Series ZPR**

Connection	One-touch fitting	Pad Form	Flat/Flat with ribs/Deep
Vacuum Entry Port	Lateral	Mounting	Male thread

Size/ø20, ø25, ø32

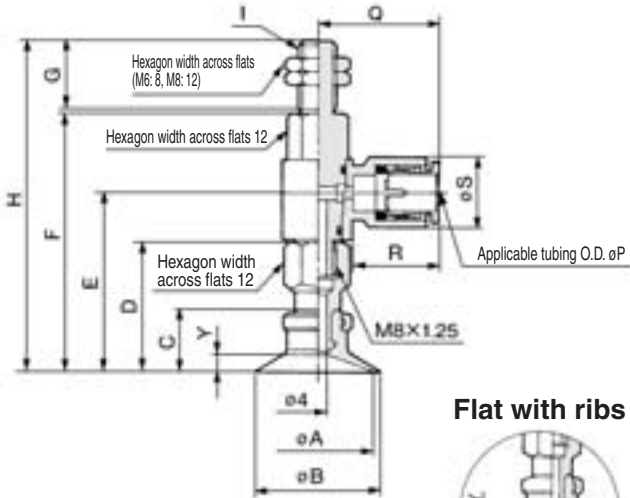

Deep: ZPR25D only

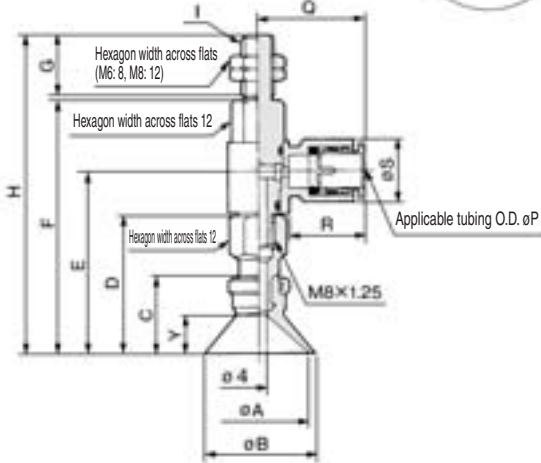

Size/ø40, ø50

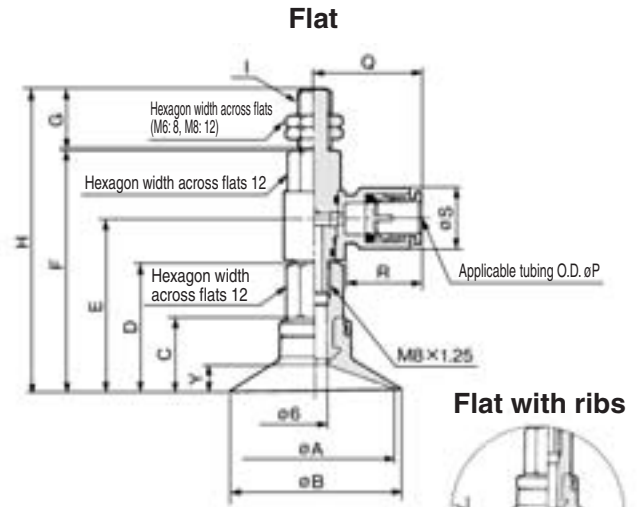

Deep: ZPR40D only

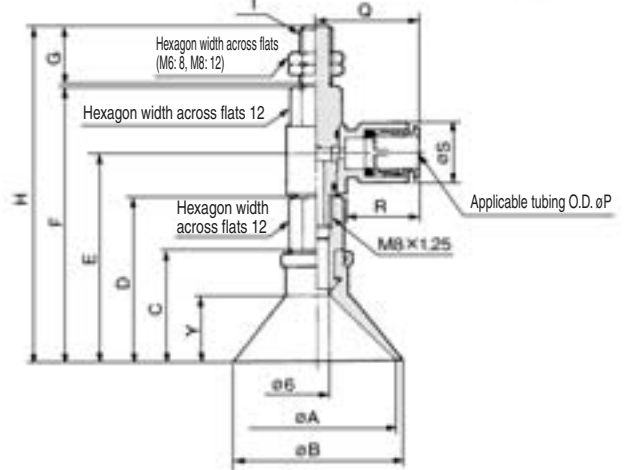

Flat/Flat with Ribs

Model	A	B	C	D	E	F	I: M6 x 1		I: M8 x 1		Y	
							G	H	G	H	Flat	Flat with ribs
ZPR20 _{UC}	20	23										
ZPR25 _{UC}	25	28	14	29	39.8	57.6	25	83.5	15	73.5	4	1.7
ZPR32 _{UC}	32	35	14.5	29.5	40.3	58.1		84		74	4.5	2.3

Deep

Model	A	B	C	D	E	F	I: M6 x 1		I: M8 x 1		Y
							G	H	G	H	
ZPR25D	25	28	20	35	48.5	63.6	25	89.5	15	79.5	10

Applicable Tubing

Applicable tubing O.D.	P	Q	R	S
ø4	4	23.3	15.8	10.4
ø6	6	24.3	16.8	12.8
ø8	8	26.2	18.7	15.2

Flat/Flat with Ribs

Model	A	B	C	D	E	F	I: M6 x 1		I: M8 x 1		Y	
							G	H	G	H	Flat	Flat with ribs
ZPR40 _{UC}	40	43	18.5	32	42.8	60.6						
ZPR50 _{UC}	50	53	19.5	33	43.8	61.6	25	86.5	15	76.5	6.5	3.3
								87.5		77.5	7.5	3.8

Deep

Model	A	B	C	D	E	F	I: M6 x 1		I: M8 x 1		Y
							G	H	G	H	
ZPR40D	40	43	29	42.5	53.3	71.1	25	97	15	87	17

Applicable Tubing

Applicable tubing O.D.	P	Q	R	S
ø6	6	24.3	16.8	12.8
ø8	8	26.2	18.7	15.2

- ZA
- ZX
- ZR
- ZM
- ZMA
- ZQ
- ZH
- ZU
- ZL
- ZY□
- ZF□
- ZP□
- SP
- ZCUK
- AMJ
- AMV
- AEP
- HEP

Related Equipment

Series ZPR

Connection	One-touch fitting	Pad Form	Bellows
Vacuum Entry Port	Lateral	Mounting	Male thread

Size/ø6, ø8

Bellows

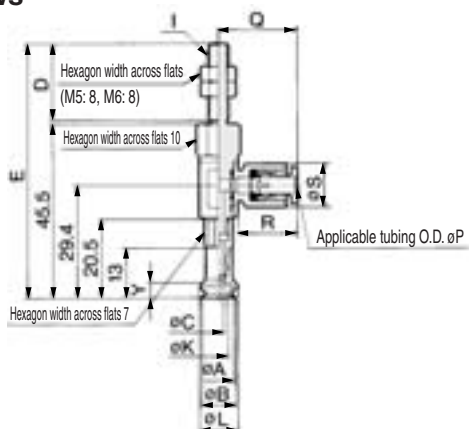

Model	A	B	C	I: M5 x 0.8		I: M6 x 1		K	L	Y
				D	E	D	E			
ZPR06B	6	7	2.5	20	66.5	25	71.5	3.3	9	4
ZPR08B	8	9		4.7	10					

Applicable Tubing

Applicable tubing O.D.	P	Q	R	S
ø4	4	20.6	15.6	10.4
ø6	6	21.6	16.6	12.8

Size/ø20, ø25, ø32

Bellows

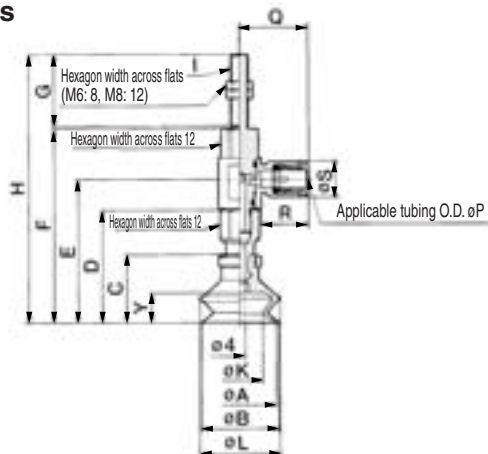

Model	A	B	C	D	E	F	I: M6 x 1		I: M8 x 1		K	L	Y
							G	H	G	H			
ZPR20B	20	22	23.5	38.5	49.3	67.1	25	93	15	83	12	25	10.5
ZPR25B	25	27	24	39	49.8	67.6	25	93.5	15	83.5	16	28	10.5
ZPR32B	32	34	29	44	54.8	72.6	25	98.5	15	88.5	19	37	14

Applicable Tubing

Applicable tubing O.D.	P	Q	R	S
ø4	4	23.3	15.8	10.4
ø6	6	24.3	16.8	12.8
ø8	8	26.2	18.7	15.2

Size/ø10, ø13, ø16

Bellows

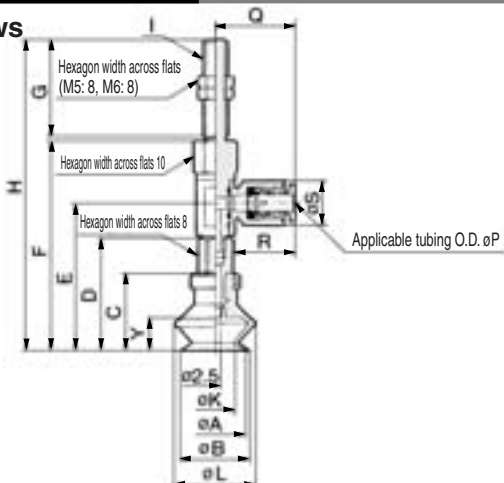

Model	A	B	C	D	E	F	I: M5 x 0.8		I: M6 x 1		K	L	Y
							G	H	G	H			
ZPR10B	10	12	16	25	33.9	50	20	71	25	76	6	14	5.5
ZPR13B	13	15	18.5	27.5	36.4	52.5	20	73.5	25	78.5	9	19	7.5
ZPR16B	16	18	20	29	37.9	54	20	75	25	80	10	21	8.5

Applicable Tubing

Applicable tubing O.D.	P	Q	R	S
ø4	4	20.6	15.6	10.4
ø6	6	21.6	16.6	12.8

Size/ø40, ø50

Bellows

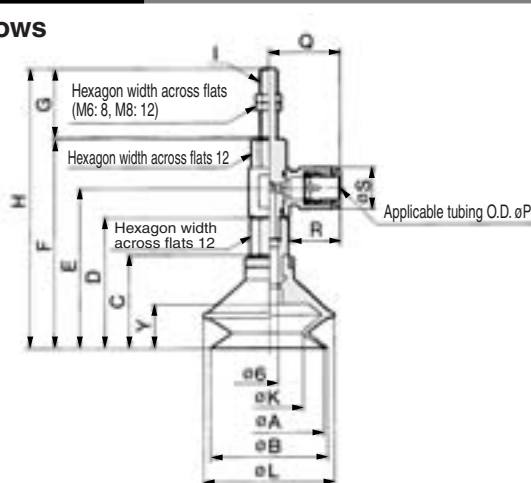

Model	A	B	C	D	E	F	I: M6 x 1		I: M8 x 1		K	L	Y
							G	H	G	H			
ZPR40B	40	43	34	47.5	58.3	76.1	25	102	15	92	24	48	16
ZPR50B	50	53	38	51.5	62.3	80.1	25	106	15	96	32	57	19

Applicable Tubing

Applicable tubing O.D.	P	Q	R	S
ø6	6	24.3	16.8	12.8
ø8	8	26.2	18.7	15.2

Connection	One-touch fitting	Pad Form	Flat/Flat with ribs/Deep/Thin flat/ Thin flat with ribs/Elliptic
Vacuum Entry Port	Lateral	Mounting	Female thread

Size/Flat $\phi 2, \phi 4, \phi 6, \phi 8$ /Thin flat/Thin flat with ribs $\phi 10, \phi 13, \phi 16$ /
Elliptic 2004, 3507, 4010

Size/ $\phi 10, \phi 13, \phi 16$

Flat/Thin flat/Thin flat with ribs

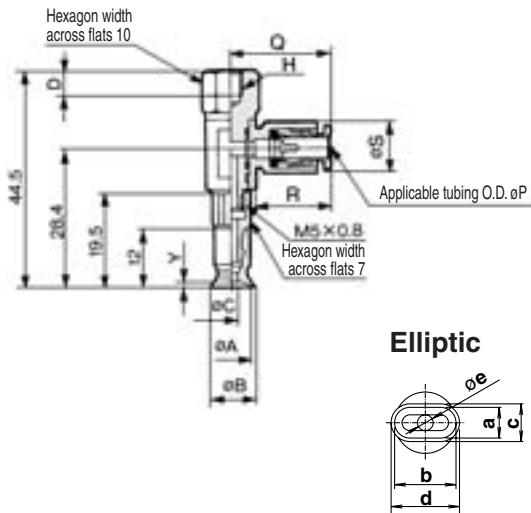

Flat

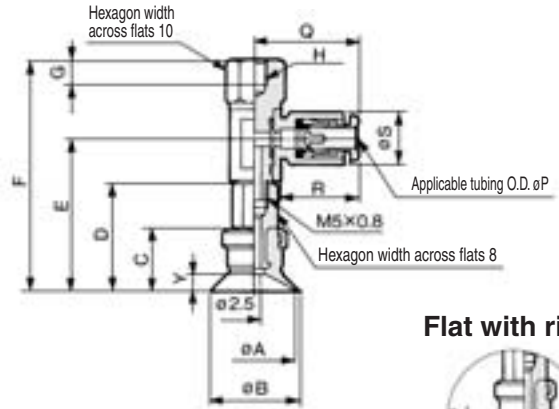

Flat with ribs



Deep: ZPR10D, 16D only

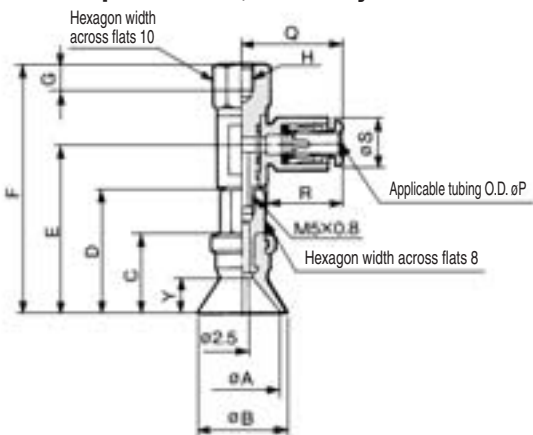

Flat

Model	A	B	C	H: M4 x 0.7 D	H: M5 x 0.8 D	Y
ZPR02U	2	2.6	1.2	4	5	0.5
ZPR04U	4	4.8	1.6			0.8
ZPR06U	6	7	2.5			
ZPR08U	8	9	2.5			1

Applicable Tubing

Applicable tubing O.D.	P	Q	R	S
$\phi 4$	4	20.6	15.6	10.4
$\phi 6$	6	21.6	16.6	12.8

Elliptic

Model	a	b	c	d	e	Y
ZPR2004U	2	4	2.6	4.6	1.2	0.3
ZPR3507U	3.5	7	4.3	7.8	1.8	0.5
ZPR4010U	4	10	5	11	2	0.8

* Dimensions of D are the same.

Thin Flat/Thin Flat with Ribs

Model	A	B	C	Y
ZPR10UT	10	11	2.5	1
ZPR13UT	13	14		1.5
ZPR16UT	16	17		0.8
ZPR10CT	10	11		1
ZPR13CT	13	14		
ZPR16CT	16	17		

* Dimensions of D are the same.

Flat/Flat with Ribs

Model	A	B	C	D	E	F	H: M5 x 0.8	H: M6 x 1	Y	
							G	G	Flat	Flat with ribs
ZPR10 ^U _C	10	12	12	21	29.9	46	5	6	3	1.7
ZPR13 ^U _C	13	15								1.8
ZPR16 ^U _C	16	18								12.5

Deep

Model	A	B	C	D	E	F	H: M5 x 0.8	H: M6 x 1	Y
							G	G	
ZPR10D	10	12	15	24	32.9	49	5	6	6
ZPR16D	16	18	16	25	33.9	50			7

Applicable Tubing

Applicable tubing O.D.	P	Q	R	S
$\phi 4$	4	20.6	15.6	10.4
$\phi 6$	6	21.6	16.6	12.8

- ZA
- ZX
- ZR
- ZM
- ZMA
- ZQ
- ZH
- ZU
- ZL
- ZY□
- ZF□
- ZP□
- SP
- ZCUK
- AMJ
- AMV
- AEP
- HEP

Related Equipment

Series ZPR

Connection	One-touch fitting	Pad Form	Flat/Flat with ribs/Deep
Vacuum Entry Port	Lateral	Mounting	Female thread

Size/ø20, ø25, ø32

Flat

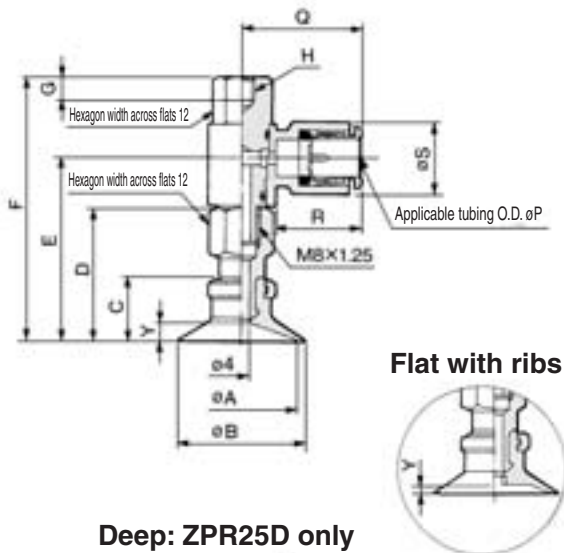

Deep: ZPR25D only

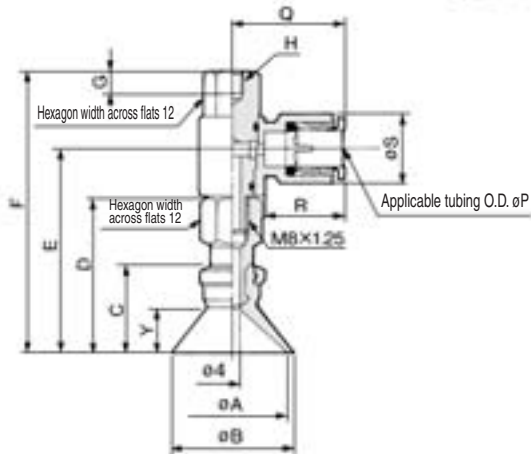

Size/ø40, ø50

Flat

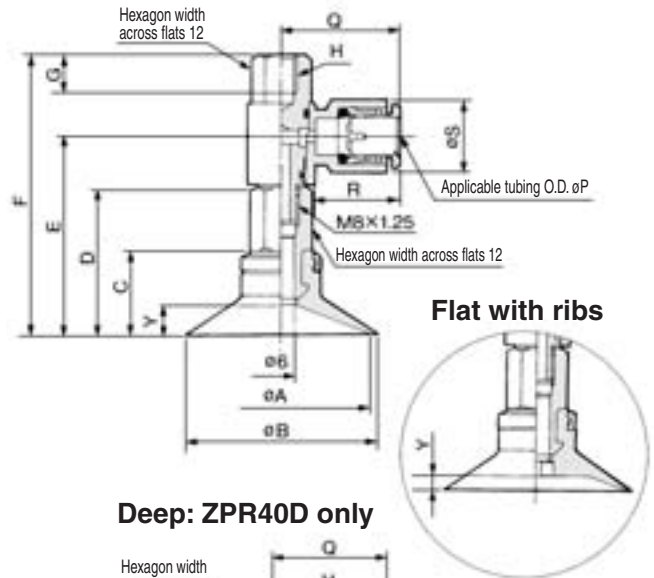

Deep: ZPR40D only

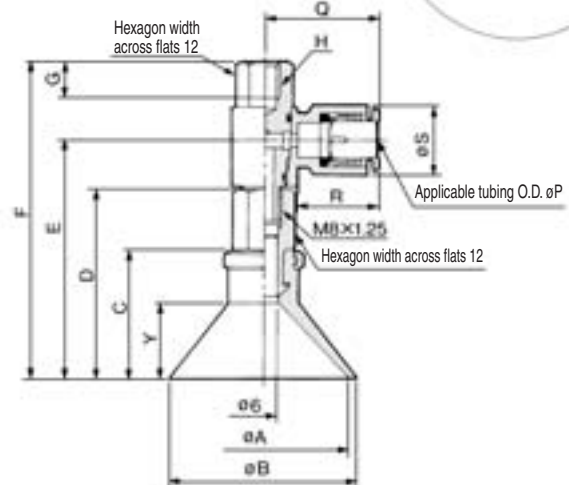

Flat/Flat with Ribs

Model	A	B	C	D	E	F	H: M5 x 0.8	H: M6 x 1	H: M8 x 1.25	Y	
							G	G	G	Flat	Flat with ribs
ZPR20 _U _C	20	23	14	29	39.8	57.6	5	6	8	4	1.7
ZPR25 _U _C	25	28	14.5	29.5	40.3	58.1				4.5	1.8
ZPR32 _U _C	32	35	14.5	29.5	40.3	58.1				4.5	2.3

Deep

Model	A	B	C	D	E	F	H: M5 x 0.8	H: M6 x 1	H: M8 x 1.25	Y
							G	G	G	
ZPR25D	25	28	20	35	45.8	63.6	5	6	8	10

Applicable Tubing

Applicable tubing O.D.	P	Q	R	S
ø4	4	23.3	15.8	10.4
ø6	6	24.3	16.8	12.8
ø8	8	26.2	18.7	15.2

Flat/Flat with Ribs

Model	A	B	C	D	E	F	H: M6 x 1	H: M8 x 1.25	Y	
							G	G	Flat	Flat with ribs
ZPR40 _U _C	40	43	18.5	32	42.8	60.6	6	8	6.5	3.3
ZPR50 _U _C	50	53	19.5	33	43.8	61.6			7.5	3.8

Deep

Model	A	B	C	D	E	F	H: M6 x 1	H: M8 x 1.25	Y
							G	G	
ZPR40D	40	43	29	42.5	53.3	71.1	6	8	17

Applicable Tubing

Applicable tubing O.D.	P	Q	R	S
ø6	6	24.3	16.8	12.8
ø8	8	26.2	18.7	15.2

Vacuum Pad/ Lateral Vacuum Entry with One-touch Fitting Without Buffer **Series ZPR**

Connection	One-touch fitting	Pad Form	Bellows
Vacuum Entry Port	Lateral	Mounting	Female thread

Size/ø6, ø8

Bellows

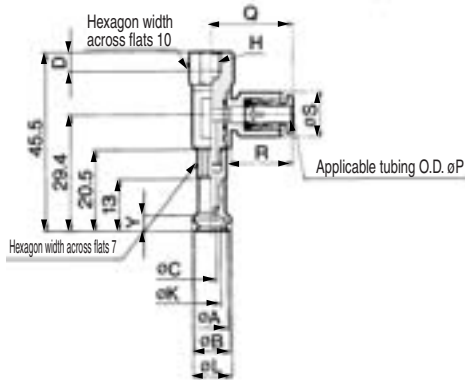

Model	A	B	C	H: M4 x 0.7		K	L	Y
				D	D			
ZPR06B	6	7	2.5	4	5	3.3	9	4
ZPR08B	8	9				4.7	10	

Applicable Tubing

Applicable tubing O.D.	P	Q	R	S
ø4	4	20.6	15.6	10.4
ø6	6	21.6	16.6	12.8

Size/ø20, ø25, ø32

Bellows

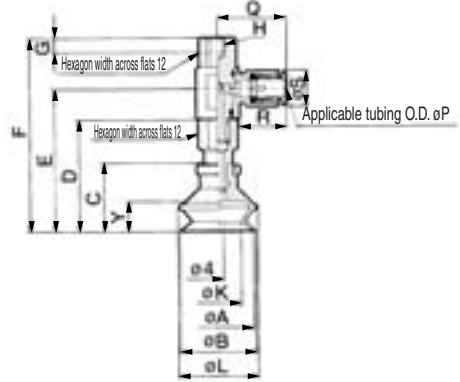

Model	A	B	C	D	E	F	H: M5 x 0.8			K	L	Y
							G	G	G			
ZPR20B	20	22	23.5	38.5	49.3	67.1	5	6	8	12	25	10.5
ZPR25B	25	27	24	39	49.8	67.6				16	28	10.5
ZPR32B	32	34	29	44	54.8	72.6				19	37	14

Applicable Tubing

Applicable tubing O.D.	P	Q	R	S
ø4	4	23.3	15.8	10.4
ø6	6	24.3	16.8	12.8
ø8	8	26.2	18.7	15.2

Size/ø10, ø13, ø16

Bellows

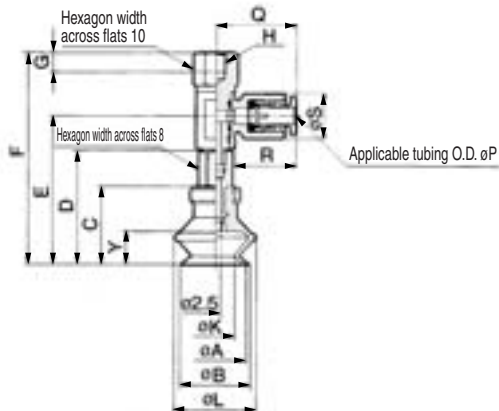

Model	A	B	C	D	E	F	H: M5 x 0.8		H: M6 x 1		K	L	Y	
							G	G	G	G				
ZPR10B	10	12	16	25	33.9	50	5	6	6	14	5.5	6	14	5.5
ZPR13B	13	15	18.5	27.5	36.4	52.5			9	19	7.5			
ZPR16B	16	18	20	29	37.9	54			10	21	8.5			

Applicable Tubing

Applicable tubing O.D.	P	Q	R	S
ø4	4	20.6	15.6	10.4
ø6	6	21.6	16.6	12.8

Size/ø40, ø50

Bellows

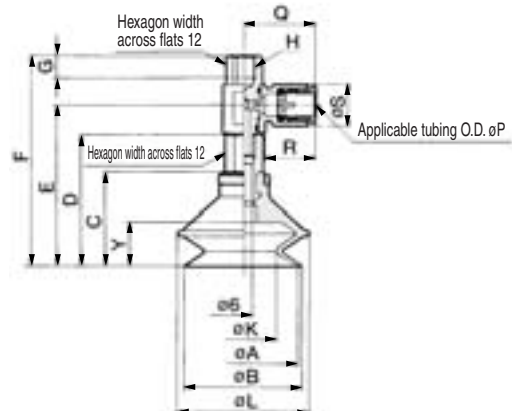

Model	A	B	C	D	E	F	H: M6 x 1		H: M8 x 1.25		K	L	Y	
							G	G	G	G				
ZPR40B	40	43	34	47.5	58.3	76.1	6	8	24	48	16	24	48	16
ZPR50B	50	53	38	51.5	62.3	80.1			32	57	19			

Applicable Tubing

Applicable tubing O.D.	P	Q	R	S
ø6	6	24.3	16.8	12.8
ø8	8	26.2	18.7	15.2

- ZA
- ZX
- ZR
- ZM
- ZMA
- ZQ
- ZH
- ZU
- ZL
- ZY□
- ZF□
- ZP□
- SP
- ZCUK
- AMJ
- AMV
- AEP
- HEP

Related Equipment



Vacuum Pad/ Lateral Vacuum Entry with One-touch Fitting With Buffer

Series ZPR



Specifications

Vacuum entry	Direction		Lateral
	Connection		One-touch fitting
Applicable tube dia.	Elliptic (2 x 4, 3.5 x 7, 4 x 10) Thin section series (ø10 to ø16) ø2 to ø8		ø4, ø6 tube
	ø10 to ø16		ø4, ø6 tube
	ø20 to ø32		ø4, ø6, ø8 tube
	ø40 to ø50		ø6, ø8 tube
Mounting	Thread dia.	Elliptic (2 x 4, 3.5 x 7, 4 x 10) Thin section series (ø10 to ø16) ø2 to ø8	M8 x 1 Male thread
		ø10 to ø16	M10 x 1 Male thread
		ø20 to ø32	M10 x 1 Male thread
		ø40 to ø50	M14 x 1 Male thread

Buffer Specifications

Dia. (mm)	ø2 to ø8	ø10 to ø32	ø40, ø50
Stroke (mm)	6, 10, 15, 25	10, 20, 30, 40, 50	10, 20, 30, 50
Spring Reactive Force (N)	0 stroke	0.8	1.0
	Full stroke	1.2	3.0
Non-rotating specification		Rotating (J)/Non-rotating (K)	

* Refer to ø2 to ø8 for Thin flat, Thin flat with ribs and Elliptic.

Pad Type

Pad form	Flat	Flat with ribs	Deep	Bellows	Thin flat/Thin flat with ribs
Pad dia. (mm)	2, 4, 6, 8, 2 x 4, 3.5 x 7, 4 x 10, 10, 13, 16, 20, 25, 32, 40, 50	10, 13, 16, 20, 25, 32, 40, 50	10, 16, 25, 40	6, 8, 10, 13, 16, 20, 25, 32, 40, 50	10, 13, 16
Material (Color)	NBR (Black), Silicon rubber (White), Urethane rubber (Brown), Fluororubber (Black with green mark) Conductive NBR (Black with one silver mark), Conductive silicon rubber (Black with two silver marks)				
Durometer	NBR (50°), Silicon rubber (40°), Urethane rubber/Fluororubber (60°) Conductive NBR (50°), Conductive silicon rubber (50°)				

Mass

(g)

Stroke (mm)	Pad form	Flat/Flat with ribs			Deep			Bellows		
	Vacuum entry port	04	06	08	04	06	08	04	06	08
6	Model									
	2004, 3507, 4010 ZPR02 to 08 Thin section flat series (10 to 16)	38	39	—	—	—	—	38	39	—
10	ZPR 10 to 16	39	40	—	39	40	—	40	41	—
10	ZPR 20 25	54	55	56	55	56	57	57	58	59
	ZPR 32	56	57	58	—	—	—	61	62	63
10	ZPR 40	—	126	127	—	128	129	—	138	139
	ZPR 50	—	132	133	—	—	—	—	145	146

Mass by Stroke

(g)

Stroke (mm)	10	15	20	25	30	40	50
Model							
ZPR02 to 08	+7	+8	—	+9	—	—	—
ZPR10 to 25	—	—	+12	—	+14	+26	+28
ZPR40, 50	—	—	-6	—	-2	—	+30

How to Order

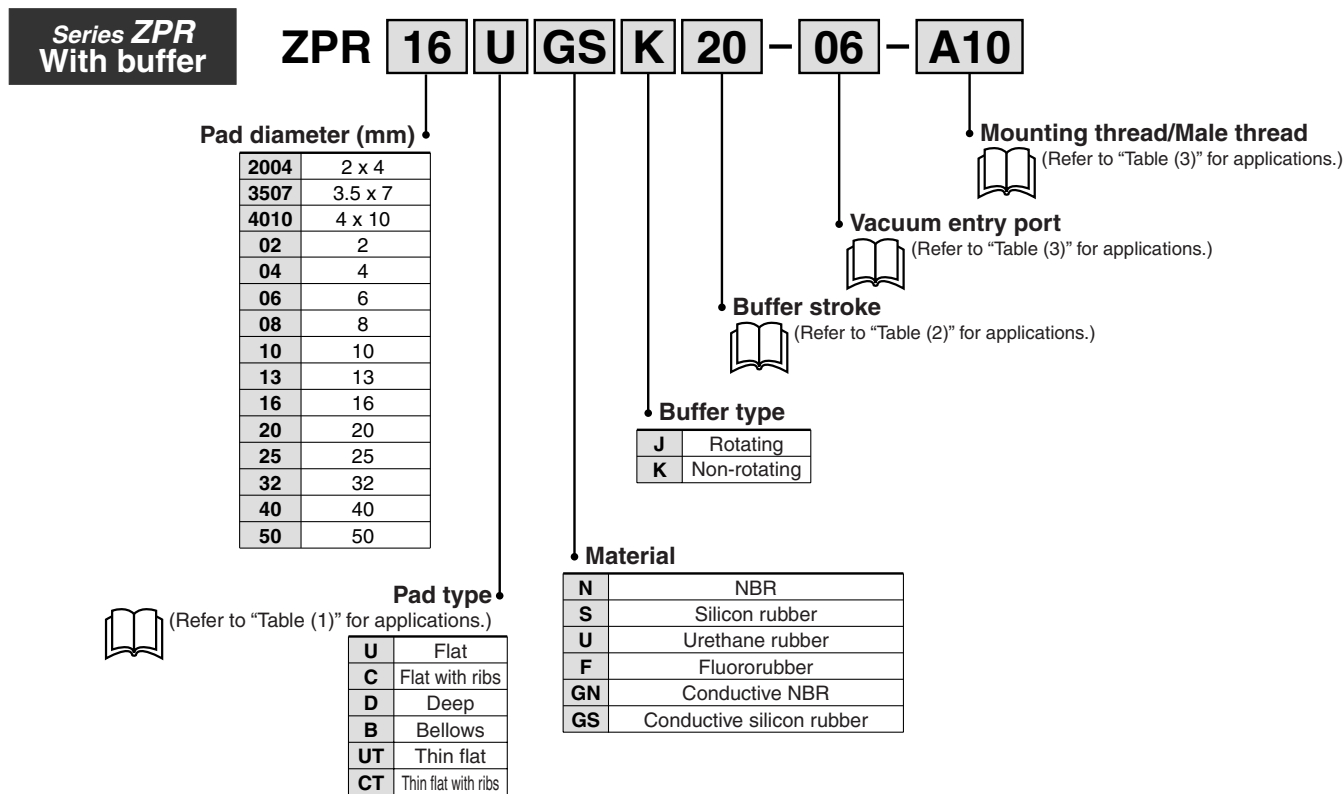

Table (1) Pad Diameter/Pad Type

Type	Dia. (mm)														
	2 x 4	3.5 x 7	4 x 10	2	4	6	8	10	13	16	20	25	32	40	50
Flat	●	●	●	●	●	●	●	●	●	●	●	●	●	●	●
Flat with ribs	—	—	—	—	—	—	—	●	●	●	●	●	●	●	●
Deep	—	—	—	—	—	—	—	●	●	●	●	●	●	●	●
Bellows	—	—	—	—	—	●	●	●	●	●	●	●	●	●	●
Thin flat	—	—	—	—	—	—	—	●	●	●	—	—	—	—	—
Thin flat with ribs	—	—	—	—	—	—	—	●	●	●	—	—	—	—	—

Table (2) Pad Diameter/Stroke

Stroke (mm)	Diameter (mm)																	
	2 x 4	3.5 x 7	4 x 10	2	4	6	8	Thin flat/ Thin flat with ribs			10	13	16	20	25	32	40	50
								10	13	16								
6 mm	●	●	●	●	●	●	●	●	●	●	—	—	—	—	—	—	—	—
10 mm	●	●	●	●	●	●	●	●	●	●	●	●	●	●	●	●	●	●
15 mm	●	●	●	●	●	●	●	●	●	●	—	—	—	—	—	—	—	—
20 mm	—	—	—	—	—	—	—	—	—	—	●	●	●	●	●	●	●	●
25 mm	●	●	●	●	●	●	●	●	●	●	—	—	—	—	—	—	—	—
30 mm	—	—	—	—	—	—	—	—	—	—	●	●	●	●	●	●	●	●
40 mm	—	—	—	—	—	—	—	—	—	—	●	●	●	●	●	●	—	—
50 mm	—	—	—	—	—	—	—	—	—	—	●	●	●	●	●	●	●	●

Table (3) Vacuum Entry/Mounting Thread Diameter

	Symbol	Thread dia./ Port size	ø2 to ø8 2 x 4, 3.5 x 7, 4 x 10 ø10 to ø16 (Thin section series)	ø10 to ø16	ø20 to ø32	ø40, ø50
Vacuum entry	04	ø4 tube	●	●	●	—
	06	ø6 tube	●	●	●	●
Mounting	08	ø8 tube	—	—	●	●
	A8	M8 x 1	●	—	—	—
	A10	M10 x 1	—	●	●	—
	A14	M14 x 1	—	—	—	●

Tightening Torque (N·m)

Mounting thread diameter	Torque
M8 x 1	2.0 ±0.5
M10 x 1	3.0 ±0.5
M14 x 1	7.0 ±0.5

- ZA
- ZX
- ZR
- ZM
- ZMA
- ZQ
- ZH
- ZU
- ZL
- ZY□
- ZF□
- ZP□
- SP
- ZCUK
- AMJ
- AMV
- AEP
- HEP
- Related Equipment

Connection	One-touch fitting	Pad Form	Flat/Flat with ribs/Deep
Vacuum Entry Port	Lateral	Mounting	Male thread

Flat/Flat with ribs/ø10, ø13, ø16

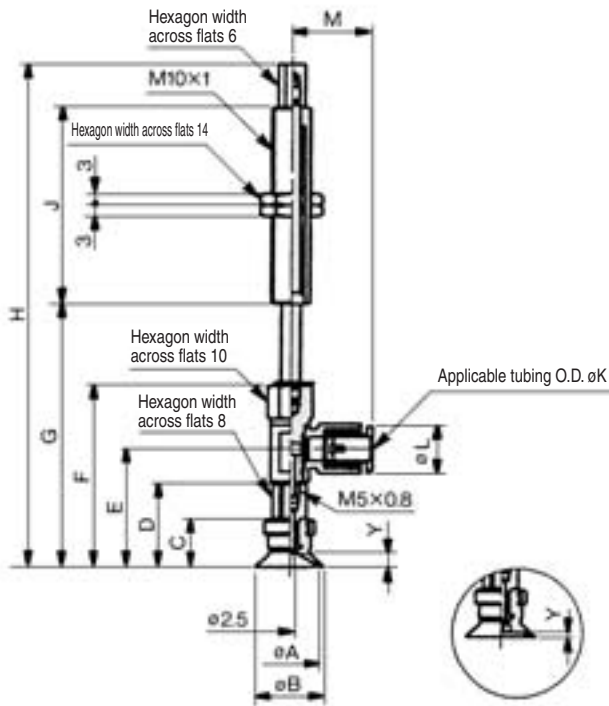

Flat with ribs

ø10, ø13, ø16

Flat/Flat with Ribs

Model	A	B	C	D	E	F	Y	
							Flat	Flat with ribs
ZPR10 ^U _C □□□□□-0□A10	10	12	12	21	29.9	46	3	1.7
ZPR13 ^U _C □□□□□-0□A10	13	15	12	21	29.9	46	3	1.8
ZPR16 ^U _C □□□□□-0□A10	16	18	12.5	21.5	30.4	46.5	3.5	1.2

Dimensions by Stroke

Model	ø10, ø13		ø16		J
	G	H	G	H	
ZPR□□ ^U _C □□□□10-0□-A10	57	91	57.5	91.5	23
ZPR□□ ^U _C □□□□20-0□-A10	67	129	67.5	129.5	51
ZPR□□ ^U _C □□□□30-0□-A10	77	139	77.5	139.5	
ZPR□□ ^U _C □□□□40-0□-A10	87	175	87.5	175.5	77
ZPR□□ ^U _C □□□□50-0□-A10	97	185	97.5	185.5	

Deep/ø10, ø16

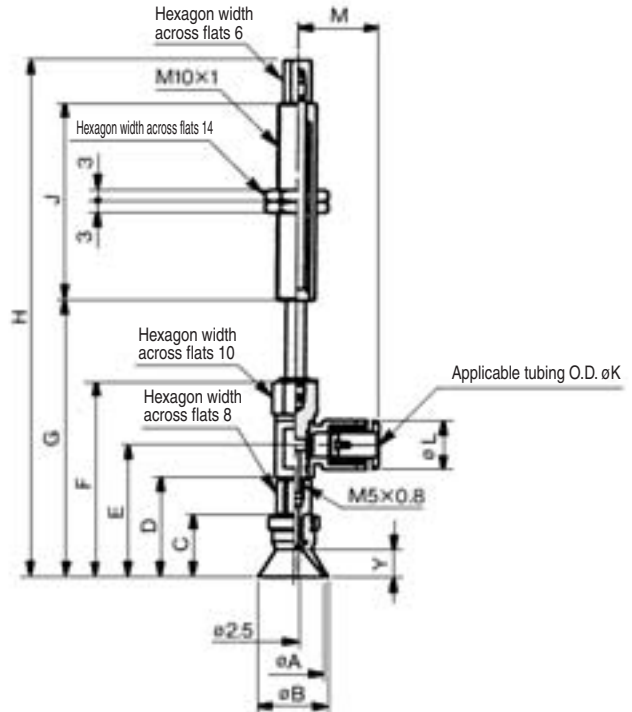

ø10, ø16

Deep

Model	A	B	C	D	E	F	Y
ZPR10D□□□□□-0□-A10	10	12	15	24	32.9	49	6
ZPR16D□□□□□-0□-A10	16	18	16	25	33.9	50	7

Dimensions by Stroke

Model	ø10		ø16		J
	G	H	G	H	
ZPR□□D□□□□10-0□-A10	60	83	61	84	23
ZPR□□D□□□□20-0□-A10	70	132	71	133	51
ZPR□□D□□□□30-0□-A10	80	142	81	143	
ZPR□□D□□□□40-0□-A10	90	178	91	179	77
ZPR□□D□□□□50-0□-A10	100	188	101	189	

One-touch Fitting

Model	K	L	M
ZPR□□□□□□□□-04-A10	4	10.4	20.6
ZPR□□□□□□□□-06-A10	6	12.8	21.6

- ZA
- ZX
- ZR
- ZM
- ZMA
- ZQ
- ZH
- ZU
- ZL
- ZY□
- ZF□
- ZP□
- SP
- ZCUK
- AMJ
- AMV
- AEP
- HEP
- Related Equipment

Series ZPR

Connection	One-touch fitting	Pad Form	Flat/Flat with ribs/Deep
Vacuum Entry Port	Lateral	Mounting	Male thread

Flat/Flat with ribs/ø20, ø25, ø32

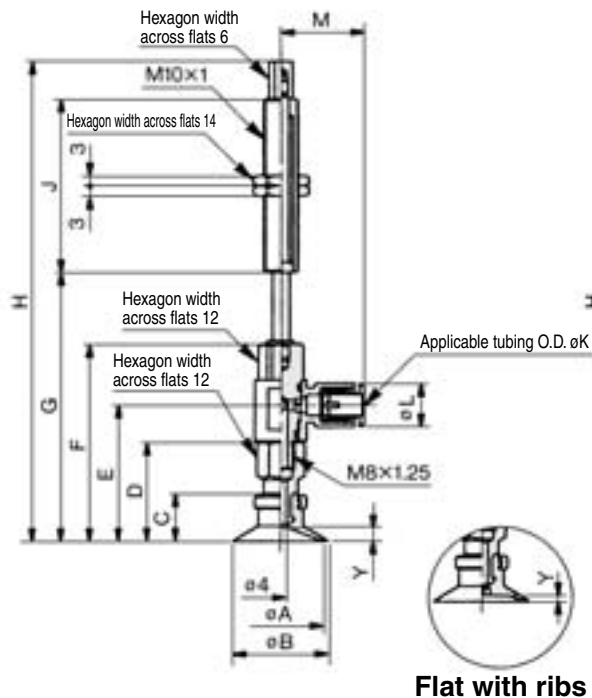

Deep/ø25

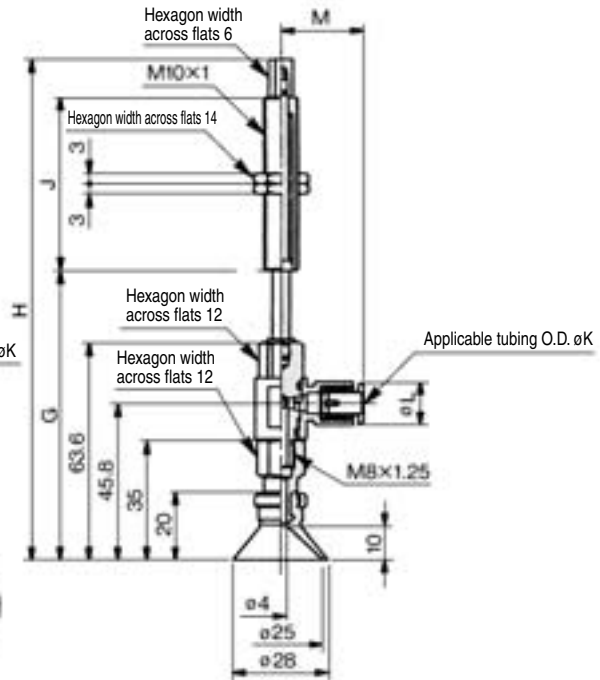

ø20, ø25, ø32

Flat/Flat with Ribs

Model	A	B	C	D	E	F	Y	
							Flat	Flat with ribs
ZPR20 ^U _C □□□□□-0□-A10	20	23	14	29	39.8	57.6	4	1.7
ZPR25 ^U _C □□□□□-0□-A10	25	28						1.8
ZPR32 ^U _C □□□□□-0□-A10	32	35	14.5	29.5	40.3	58.1	4.5	2.3

Dimensions by Stroke

Model	ø20, ø25		ø32		J
	G	H	G	H	
ZPR□□ ^U _C □□□□10-0□-A10	68.6	102.6	69.1	103.1	23
ZPR□□ ^U _C □□□□20-0□-A10	78.6	140.6	79.1	141.1	51
ZPR□□ ^U _C □□□□30-0□-A10	88.6	150.6	89.1	151.1	
ZPR□□ ^U _C □□□□40-0□-A10	98.6	186.6	99.1	187.1	77
ZPR□□ ^U _C □□□□50-0□-A10	108.6	196.6	109.6	197.1	

ø25

Deep

Model	G	H	J
ZPR25D□□□□10-0□-A10	74.6	108.6	23
ZPR25D□□□□20-0□-A10	84.6	146.6	51
ZPR25D□□□□30-0□-A10	94.6	156.6	
ZPR25D□□□□40-0□-A10	104.6	192.6	77
ZPR25D□□□□50-0□-A10	114.6	202.6	

One-touch Fitting

Model	K	L	M
ZPR□□□□□□□□-04-A10	4	10.4	23.3
ZPR□□□□□□□□-06-A10	6	12.8	24.3
ZPR□□□□□□□□-08-A10	8	15.2	26.2

Connection	One-touch fitting	Pad Form	Flat/Flat with ribs/Deep
Vacuum Entry Port	Lateral	Mounting	Male thread

Flat/Flat with ribs/ø40, ø50

Deep/ø40

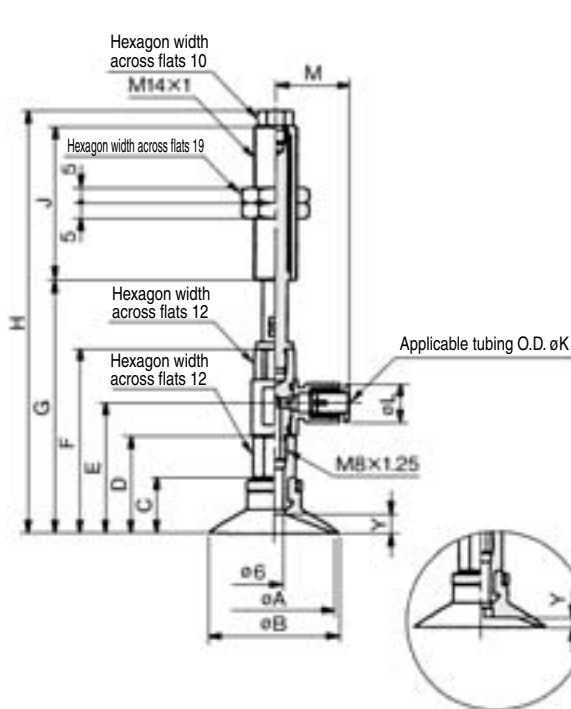

Flat with ribs

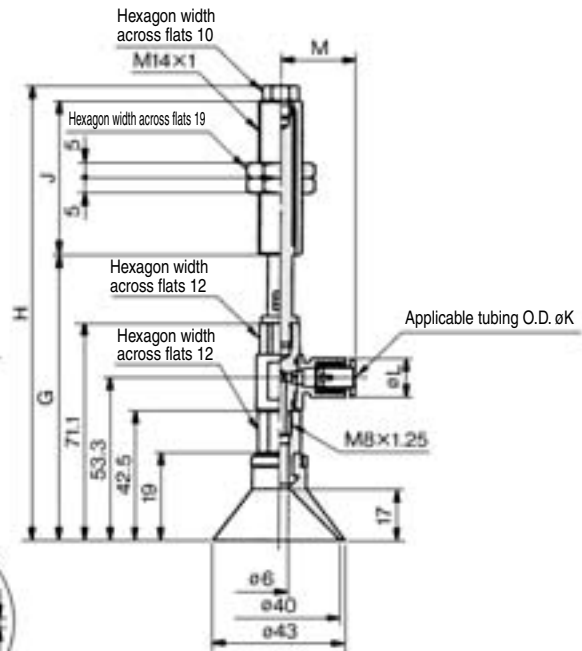

ø40, ø50

Flat/Flat with Ribs

Model	A	B	C	D	E	F	Y	
							Flat	Flat with ribs
ZPR40 ^U _C □□□□□□-0□-A14	40	43	18.5	32	42.8	60.6	6.5	3.3
ZPR50 ^U _C □□□□□□-0□-A14	50	53	19.5	33	43.8	61.6	7.5	3.8

Dimensions by Stroke

Model	ø40		ø50		J
	G	H	G	H	
ZPR□□ ^U _C □□□□□□10-0□-A14	72.6	140.6	73.6	141.6	50
ZPR□□ ^U _C □□□□□□20-0□-A14	82.6	137.6	83.6	138.6	
ZPR□□ ^U _C □□□□□□30-0□-A14	92.6	147.6	93.6	148.6	
ZPR□□ ^U _C □□□□□□50-0□-A14	112.6	192.6	113.6	193.6	

ø40

Deep

Model	G	H	J
ZPR40D□□□□10-0□-A14	83.1	151.1	50
ZPR40D□□□□20-0□-A14	93.1	148.1	
ZPR40D□□□□30-0□-A14	103.1	158.1	75
ZPR40D□□□□50-0□-A14	123.1	203.1	

One-touch Fitting

Model	K	L	M
ZPR□□□□□□□□-06-A14	6	12.8	24.3
ZPR□□□□□□□□-08-A14	8	15.2	26.2

- ZA
- ZX
- ZR
- ZM
- ZMA
- ZQ
- ZH
- ZU
- ZL
- ZY□
- ZF□
- ZP□
- SP
- ZCUK
- AMJ
- AMV
- AEP
- HEP

Related Equipment

Connection	One-touch fitting	Pad Form	Bellows
Vacuum Entry Port	Lateral	Mounting	Male thread

Bellows/ø20, ø25, ø32

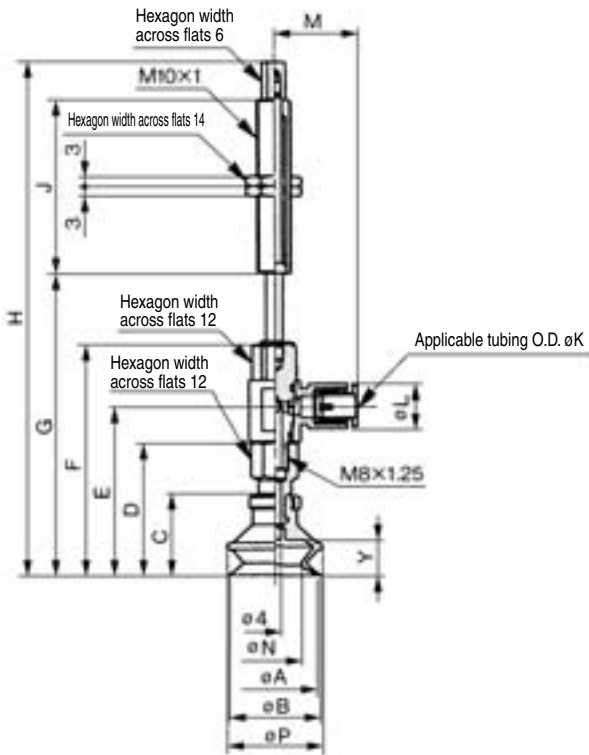

ø20, ø25, ø32

Bellows

Model	A	B	C	D	E	F	N	P	Y
ZPR20B□□□□□-0□-A10	20	22	23.5	38.5	49.3	67.1	12	25	10.5
ZPR25B□□□□□-0□-A10	25	27	24	39	49.8	67.6	16	28	
ZPR32B□□□□□-0□-A10	32	34	29	44	54.8	72.6	19	37	

Dimensions by Stroke

Model	ø20		ø25		ø32		J	K: 4		K: 6		K: 8	
	G	H	G	H	G	H		L	M	L	M	L	M
	ZPR□□B□□□□10-0□-A10	78.1	112.1	78.6	112.6	83.6		117.6	23				
ZPR□□B□□□□20-0□-A10	88.1	150.1	88.6	150.6	93.6	155.6	51	10.4	23.3	12.8	24.3	15.2	26.2
ZPR□□B□□□□30-0□-A10	98.1	160.1	98.6	160.6	103.6	165.6							
ZPR□□B□□□□40-0□-A10	108.1	196.1	108.6	196.6	113.6	201.6	77						
ZPR□□B□□□□50-0□-A10	118.1	206.1	118.6	206.6	123.6	211.6							

Bellows/ø40, ø50

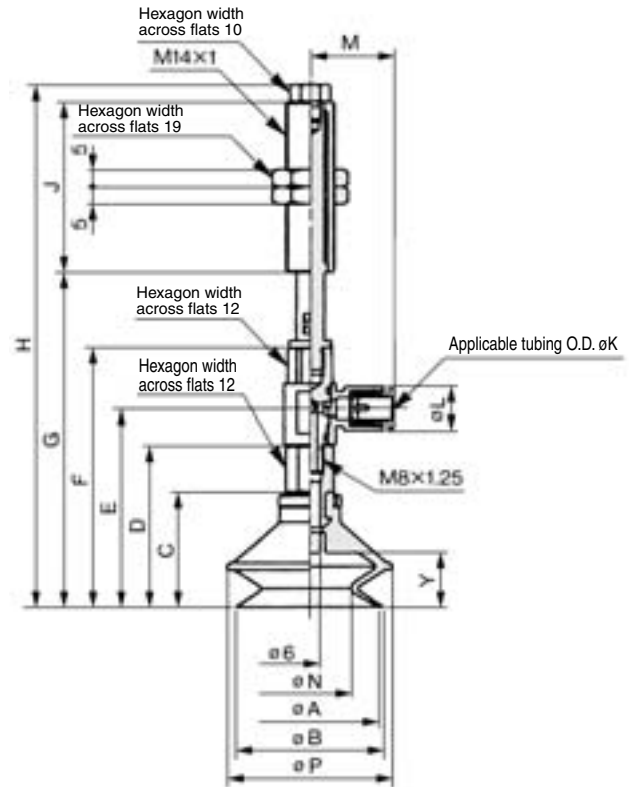

ø40, ø50

Bellows

Model	A	B	C	D	E	F	N	P	Y
ZPR40B□□□□□-0□-A14	40	43	34	47.5	58.3	76.1	24	48	16
ZPR50B□□□□□-0□-A14	50	53	38	51.5	62.3	80.1	32	57	19

Dimensions by Stroke

Model	ø40		ø50		J	K: 6		K: 8	
	G	H	G	H		L	M	L	M
	ZPR□□B□□□□10-0□-A14	88.1	156.1	92.1		160.1	50	12.8	24.3
ZPR□□B□□□□20-0□-A14	98.1	153.1	102.1	157.1					
ZPR□□B□□□□30-0□-A14	108.1	163.1	112.1	167.1					
ZPR□□B□□□□50-0□-A14	128.1	208.1	132.1	212.1					

- ZA
- ZX
- ZR
- ZM
- ZMA
- ZQ
- ZH
- ZU
- ZL
- ZY□
- ZF□
- ZP□
- SP
- ZCUK
- AMJ
- AMV
- AEP
- HEP

Related Equipment

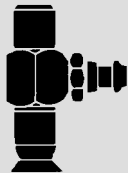

Vacuum Pad/ Lateral Vacuum Entry with Barb Fitting Without Buffer

Series ZPY



Specifications

Vacuum entry	Direction		Lateral	
	Applicable tube dia.	Connection	Barb fitting	
Elliptic (2 x 4, 3.5 x 7, 4 x 10) Thin section series (ø10 to ø16) ø2 to ø8		ø10 to ø16	ø4, ø6 Nylon tube, ø4, ø6 Urethane tube	
		ø20 to ø32	ø4, ø6 Nylon tube, ø4, ø6 Urethane tube	
		ø40 to ø50	ø6 Nylon tube, ø6 Urethane tube	
Mounting	Thread dia.	Connection	Male thread	Female thread
		Elliptic (2 x 4, 3.5 x 7, 4 x 10) Thin section series (ø10 to ø16) ø2 to ø8	M5 x 0.8, M6 x 1	M4 x 0.7, M5 x 0.8
			M5 x 0.8, M6 x 1	M5 x 0.8, M6 x 1
			M6 x 1, M8 x 1	M5 x 0.8, M6 x 1, M8 x 1.25
			M6 x 1, M8 x 1	M6 x 1, M8 x 1.25

Pad Type

Pad form	Flat	Flat with ribs	Deep	Bellows	Thin flat/Thin flat with ribs
Pad dia. (mm)	2, 4, 6, 8, 2 x 4, 3.5 x 7, 4 x 10, 10, 13, 16, 20, 25, 32, 40, 50	10, 13, 16, 20, 25, 32, 40, 50	10, 16, 25, 40	6, 8, 10, 13, 16, 20, 25, 32, 40, 50	10, 13, 16
Material (Color)	NBR (Black), Silicon rubber (White), Urethane rubber (Brown), Fluororubber (Black with green mark) Conductive NBR (Black with one silver mark), Conductive silicon rubber (Black with two silver marks)				
Durometer	NBR (50°), Silicon rubber (40°), Urethane rubber/Fluororubber (60°) Conductive NBR (50°), Conductive silicon rubber (50°)				

Mass/Male Thread (Female thread)

(g)

Model	Flat		Flat with ribs			Deep			Bellows			
	M5	M6	M8	M5	M6	M8	M5	M6	M8	M5	M6	M8
ZPY02 to 08 2004 3507 4010 10 to 16 (Thin section series)	15 (11)	15	—	—	—	—	—	—	—	15 (11) except ø2, ø4	15 (11) except ø2, ø4	—
ZPY10	—	—	—	—	—	—	31 (27)	33 (26)	—	—	—	—
ZPY13	32 (25)	33 (25)	—	32 (25)	33 (25)	—	—	—	—	—	33 (25)	33 —
ZPY16	—	—	—	—	—	—	32 (27)	38 (27)	—	—	—	—
ZPY20	—	—	—	—	—	—	—	—	—	—	—	—
ZPY25	— (30)	38 (30)	38 (29)	— (30)	38 (30)	38 (29)	— (30)	38 (30)	38 (28)	— (30)	38 (30)	38 (29)
ZPY32	—	—	—	—	—	—	—	—	—	—	—	—
ZPY40	—	43 (36)	47 (34)	—	42 (35)	46 (33)	—	44 (37)	48 (35)	—	43 (36)	47 (34)
ZPY50	—	44 (38)	49 (35)	—	46 (38)	50 (37)	—	—	—	—	44 (38)	49 (35)

* (): Figures for female thread connections.

How to Order

Series ZPY
Without buffer

Pad dia.
Pad type
Material
Vacuum entry port
Mounting thread
ZPY 02 U N - N4 - A5

Pad diameter (mm)

2004	2 x 4
3507	3.5 x 7
4010	4 x 10
02	2
04	4
06	6
08	8
10	10
13	13
16	16
20	20
25	25
32	32
40	40
50	50

Mounting thread
(Refer to "Table (2)" for applications.)

Vacuum entry port
(Refer to "Table (2)" for applications.)

Table (2) Vacuum Entry/Mounting Thread Diameter

Connection	Symbol	Thread dia./Port size	ø2 to ø8	ø10 to ø16	ø20 to ø32	ø40 to ø50	
			2 x 4 3.5 x 7 4 x 10 ø10 to ø16 (thin section series)				
Vacuum entry	Barb fitting	N4	ø4 Nylon tube	●	●	—	
		N6	ø6 Nylon tube	●	●	●	
	Urethane tube	U4	ø4 Urethane tube	●	●	—	
		U6	ø6 Urethane tube	●	●	●	
Mounting	Male thread	A5	M5 x 0.8	●	—	—	
		A6	M6 x 1	●	●	●	
		A8	M8 x 1	—	—	●	●
		B4	M4 x 0.7	●	—	—	—
	Female thread	B5	M5 x 0.8	●	●	●	—
		B6	M6 x 1	—	●	●	●
		B8	M8 x 1.25	—	—	●	●

Pad type
(Refer to "Table (1)" for applications.)

U	Flat
C	Flat with ribs
D	Deep
B	Bellows
UT	Thin flat
CT	Thin flat with ribs

Material

N	NBR
S	Silicon rubber
U	Urethane rubber
F	Fluororubber
GN	Conductive NBR
GS	Conductive silicon rubber

Table (1) Pad Diameter/Pad Type

Type	Dia. (mm)														
	2 x 4	3.5 x 7	4 x 10	2	4	6	8	10	13	16	20	25	32	40	50
Flat	●	●	●	●	●	●	●	●	●	●	●	●	●	●	●
Flat with ribs	—	—	—	—	—	—	—	●	●	●	●	●	●	●	●
Deep	—	—	—	—	—	—	—	●	—	●	—	●	—	●	—
Bellows	—	—	—	—	—	●	●	●	●	●	●	●	●	●	●
Thin flat	—	—	—	—	—	—	—	●	●	●	—	—	—	—	—
Thin flat with ribs	—	—	—	—	—	—	—	●	●	●	—	—	—	—	—

- ZA
- ZX
- ZR
- ZM
- ZMA
- ZQ
- ZH
- ZU
- ZL
- ZY□
- ZF□
- ZP□
- SP
- ZCUK
- AMJ
- AMV
- AEP
- HEP
- Related Equipment

Series ZPY

Connection	Barb Fitting	Pad Form	Flat/Flat with ribs/Deep/ Thin flat/Thin flat with ribs/Elliptic
Vacuum Entry Port	Lateral	Mounting	Male thread

Size/Flat $\phi 2, \phi 4, \phi 6, \phi 8$ /Thin flat/Thin flat with ribs $\phi 10, \phi 13, \phi 16$ /
Elliptic 2004, 3507, 4010

Size/ $\phi 10, \phi 13, \phi 16$

Flat/Thin flat/Thin flat with ribs

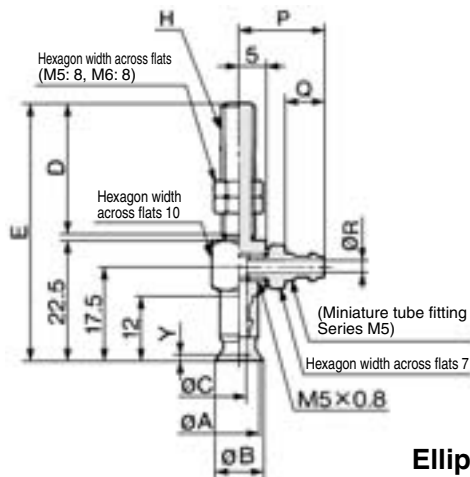

Elliptic

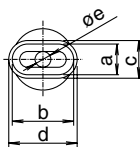

Flat

Model	A	B	C	H: M5 x 0.8		H: M6 x 1		Y
				D	E	D	E	
ZPY02U	2	2.6	1.2	20	44	25	49.5	0.5
ZPY04U	4	4.8	1.6					0.8
ZPY06U	6	7	2.5					0.8
ZPY08U	8	9						1

Elliptic

Model	a	b	c	d	e	Y
ZPY2004U	2	4	2.6	4.6	1.2	0.3
ZPY3507U	3.5	7	4.3	7.8	1.8	0.5
ZPY4010U	4	10	5	11	2	0.8

Thin Flat/Thin Flat with Ribs

Model	A	B	C	Y
ZPY10UT	10	11	2.5	1
ZPY13UT	13	14		1.5
ZPY16UT	16	17		0.8
ZPY10CT	10	11		1
ZPY13CT	13	14		
ZPY16CT	16	17		

* Dimensions of D, E are the same.

Applicable Tubing

Applicable tube O.D.	P	Q	R
N4 (Nylon tube $\phi 4/2.5$)	13.5	5	1.8
N6 (Nylon tube $\phi 6/4$)	15.5	7	2.5
U4 (Soft tube $\phi 4/2.5$)	13.5	5	1.8
U6 (Soft tube $\phi 6/4$)	15.5	7	2.5

Flat

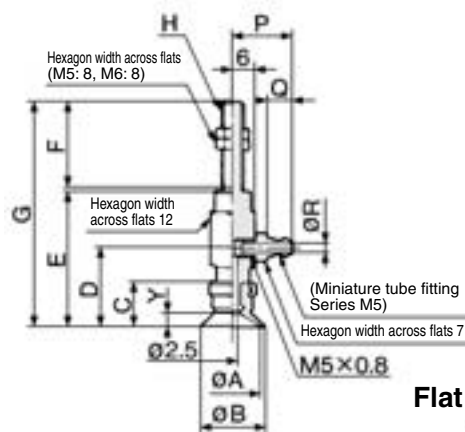

Flat with ribs

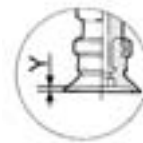

Deep: ZPY10D,16D only

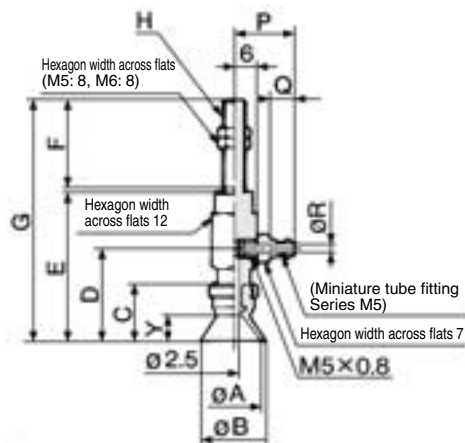

Flat/Flat with Ribs

Model	A	B	C	D	E	H: M5 x 0.8		H: M6 x 1		Y	
						F	G	F	G	Flat	Flat with ribs
ZPY10U	10	12	12	22	38	20	59	25	64	3	1.7
ZPY13U	13	15									1.8
ZPY16U	16	18	12.5	22.5	38.5		59.5		64.5	3.5	1.2

Deep

Model	A	B	C	D	E	H: M5 x 0.8		H: M6 x 1		Y
						F	G	F	G	
ZPY10D	10	12	15	25	41	20	62	25	67	6
ZPY16D	16	18	16	26	42		63		68	7

Applicable Tubing

Applicable tube O.D.	P	Q	R
N4 (Nylon tube $\phi 4/2.5$)	14.5	5	1.8
N6 (Nylon tube $\phi 6/4$)	16.5	7	2.5
U4 (Soft tube $\phi 4/2.5$)	14.5	5	1.8
U6 (Soft tube $\phi 6/4$)	16.5	7	2.5

Vacuum Pad/ Lateral Vacuum Entry with Barb Fitting without Buffer **Series ZPY**

Connection	Barb Fitting	Pad Form	Flat/Flat with ribs/Deep/ Thin flat/Thin flat with ribs/Elliptic
Vacuum Entry Port	Lateral	Mounting	Male thread

Size/ø20, ø25, ø32

Size/ø40, ø50

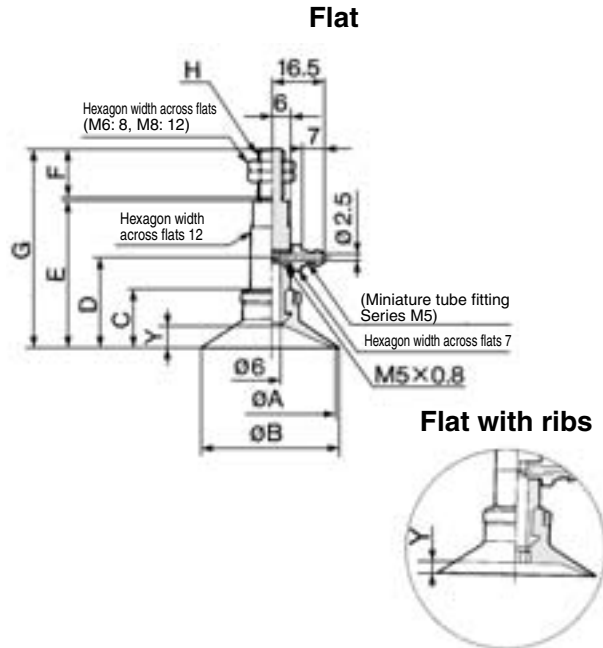
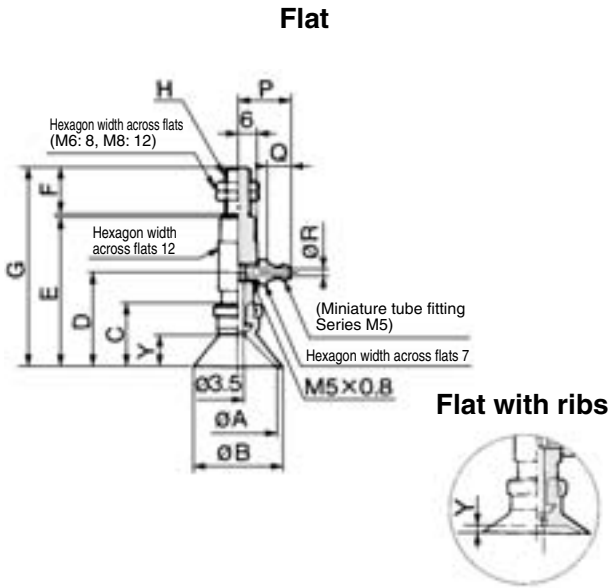

Deep: ZPY25D only

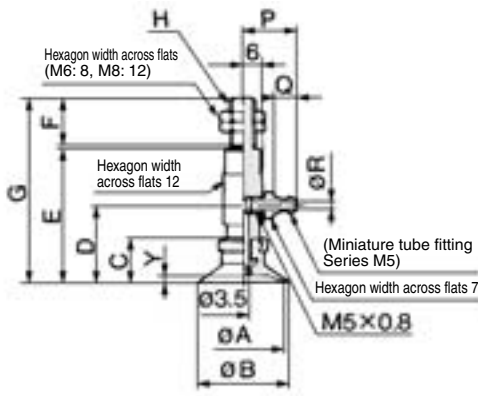

Deep: ZPY40D only

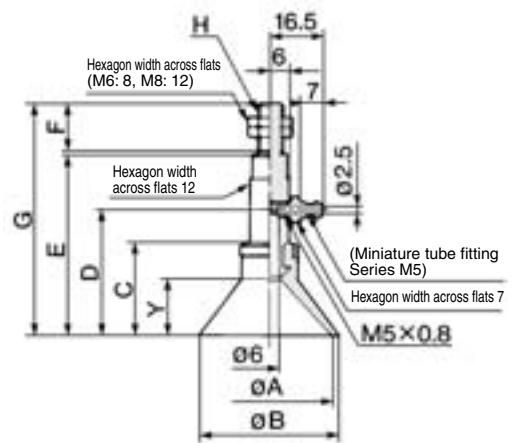

Flat/Flat with Ribs

Model	A	B	C	D	E	H: M6 x 1		H: M8 x 1		Y	
						F	G	F	G	Flat	Flat with ribs
ZPY20 _U	20	23	14	24	42	25	68	15	58	4	1.7
ZPY25 _U	25	28	14	24	42	25	68	15	58	4	1.8
ZPY32 _U	32	35	14.5	24.5	42.5	25	68.5	15	58.5	4.5	2.3

Deep

Model	A	B	C	D	E	H: M6 x 1		H: M8 x 1		Y
						F	G	F	G	
ZPY25D	25	28	20	30	48	25	74	15	64	10

Applicable Tubing

Applicable tube O.D.	P	Q	R
N4 (Nylon tube ø4/2.5)	14.5	5	1.8
N6 (Nylon tube ø6/4)	16.5	7	2.5
U4 (Soft tube ø4/2.5)	14.5	5	1.8
U6 (Soft tube ø6/4)	16.5	7	2.5

Flat/Flat with Ribs

Model	A	B	C	D	E	H: M6 x 1		H: M8 x 1		Y	
						F	G	F	G	Flat	Flat with ribs
ZPY40 _U	40	43	18.5	28.5	46.5	25	72.5	15	62.5	6.5	3.3
ZPY50 _U	50	53	19.5	29.5	47.5	25	73.5	15	63.5	7.5	3.8

Deep

Model	A	B	C	D	E	H: M6 x 1		H: M8 x 1		Y
						F	G	F	G	
ZPY40D	40	43	29	39	57	25	83	15	73	17

- ZA
- ZX
- ZR
- ZM
- ZMA
- ZQ
- ZH
- ZU
- ZL
- ZY□
- ZF□
- ZP□
- SP
- ZCUK
- AMJ
- AMV
- AEP
- HEP
- Related Equipment

Series ZPY

Connection	Barb Fitting	Pad Form	Bellows
Vacuum Entry Port	Lateral	Mounting	Male thread

Size/ø6, ø8

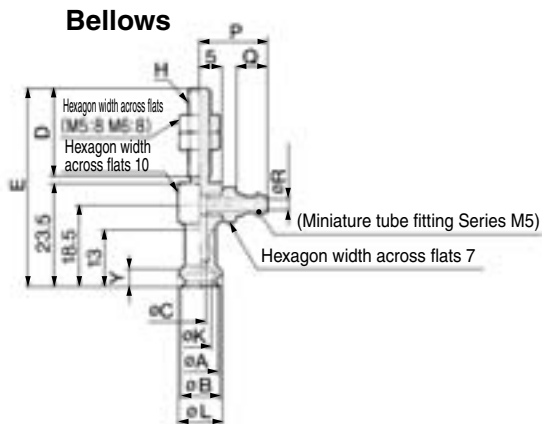

Model	A	B	C	H: M5 x 0.8		H: M6 x 1		K	L	Y
				D	E	D	E			
ZPY06B	6	7	2.5	20	45	25	50.5	3.3	9	4
ZPY08B	8	9		4.7	10					

Applicable Tubing

Applicable tube O.D.	P	Q	R
N4 (Nylon tube ø4/2.5)	13.5	5	1.8
N6 (Nylon tube ø6/4)	15.5	7	2.5
U4 (Urethane tube ø4/2.5)	13.5	5	1.8
U6 (Urethane tube ø6/4)	15.5	7	2.5

Size/ø20, ø25, ø32

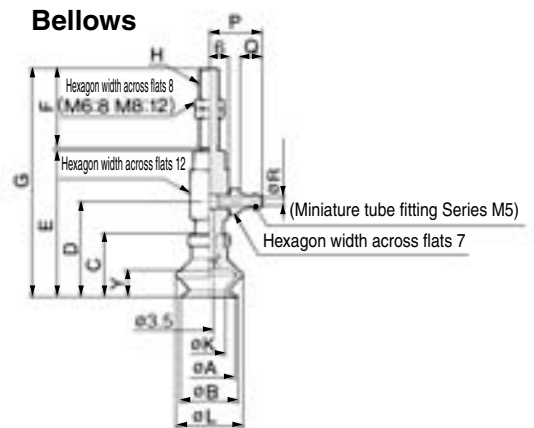

Model	A	B	C	D	E	H: M6 x 1		H: M8 x 1		K	L	Y
						F	G	F	G			
ZPY20B	20	22	23.5	33.5	51.5	25	79.5	15	69.5	12	25	10.5
ZPY25B	25	27	24	34	52	80	85	70	16	28		
ZPY32B	32	34	29	39	57	75	19	37	14			

Applicable Tubing

Applicable tube O.D.	P	Q	R
N4 (Nylon tube ø4/2.5)	14.5	5	1.8
N6 (Nylon tube ø6/4)	16.5	7	2.5
U4 (Urethane tube ø4/2.5)	14.5	5	1.8
U6 (Urethane tube ø6/4)	16.5	7	2.5

Size/ø10, ø13, ø16

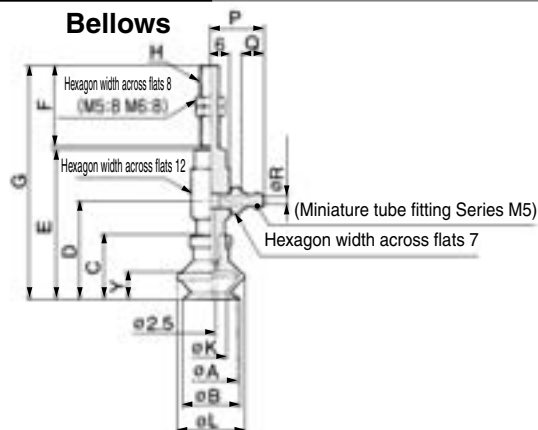

Model	A	B	C	D	E	H: M5 x 0.8		H: M6 x 1		K	L	Y
						F	G	F	G			
ZPY10B	10	12	16	26	42	20	63	25	68	6	14	5.5
ZPY13B	13	15	18.5	28.5	44.5	65.5	70.5	72	9	19	7.5	
ZPY16B	16	18	20	30	46	67	72	10	21	8.5		

Applicable Tubing

Applicable tube O.D.	P	Q	R
N4 (Nylon tube ø4/2.5)	14.5	5	1.8
N6 (Nylon tube ø6/4)	16.5	7	2.5
U4 (Urethane tube ø4/2.5)	14.5	5	1.8
U6 (Urethane tube ø6/4)	16.5	7	2.5

Size/ø40, ø50

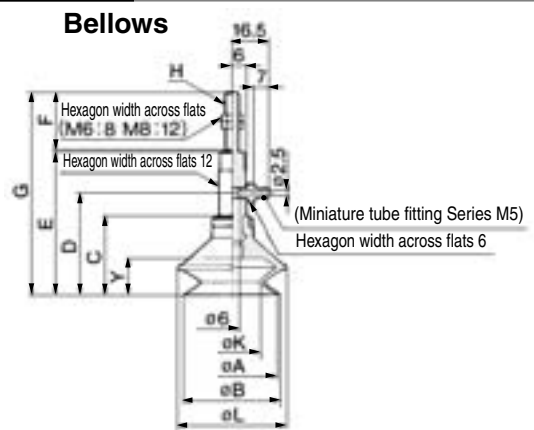

Model	A	B	C	D	E	H: M6 x 1		H: M8 x 1		K	L	Y
						F	G	F	G			
ZPY40B	40	43	34	44	62	25	88	15	78	24	48	16
ZPY50B	50	53	38	48	66	92	82	32	57	19		

Vacuum Pad/ Lateral Vacuum Entry with Barb Fitting without Buffer **Series ZPY**

Connection	Barb fitting	Pad Form	Flat/Flat with ribs/Deep/Thin flat/ Thin flat with ribs/Elliptic
Vacuum Entry Port	Lateral	Mounting	Female thread

Size/Flat $\phi 2, \phi 4, \phi 6, \phi 8$ /Thin flat/Thin flat with ribs $\phi 10, \phi 13, \phi 16$ /
Elliptic 2004, 3507, 4010

Flat/Thin flat/Thin flat with ribs

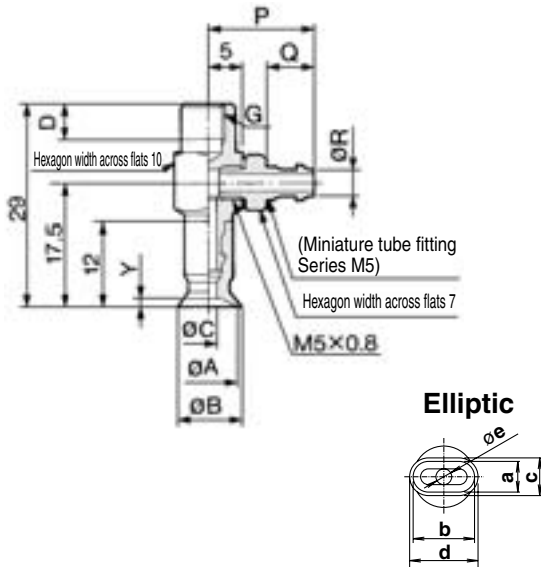

Size/ $\phi 10, \phi 13, \phi 16$

Flat

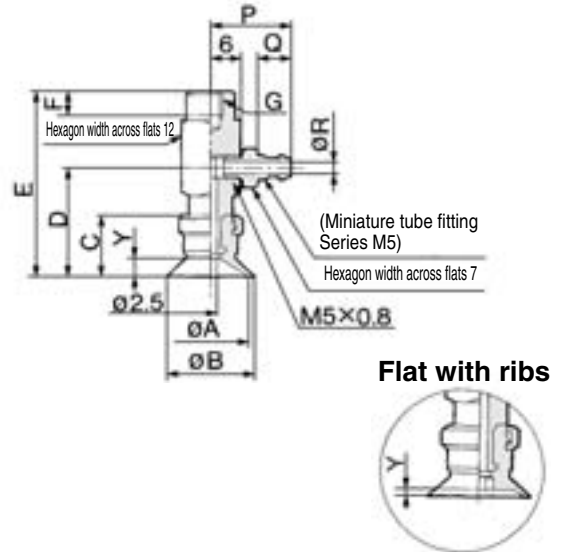

Deep: ZPY10D, 16D only

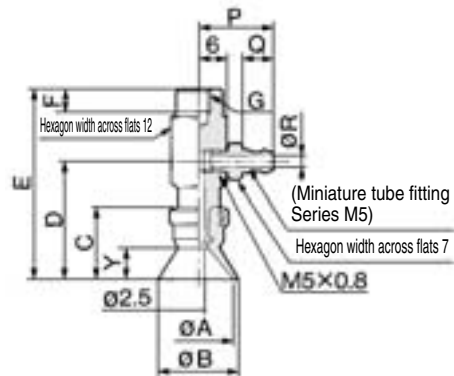

Flat/Flat with Ribs

Model	A	B	C	G: M4 x 0.7		Y
				D	D	
ZPY02U	2	2.6	1.2	4	5	0.5
ZPY04U	4	4.8	1.6			0.8
ZPY06U	6	7	2.5			1
ZPY08U	8	9				

Elliptic

Model	a	b	c	d	e	Y
ZPY2004U	2	4	2.6	4.6	1.2	0.3
ZPY3507U	3.5	7	4.3	7.8	1.8	0.5
ZPY4010U	4	10	5	11	2	0.8

Thin Flat /Thin Flat with Ribs

Model	A	B	C	Y
ZPY10UT	10	11	2.5	1
ZPY13UT	13	14		1.5
ZPY16UT	16	17		0.8
ZPY10CT	10	11		1
ZPY13CT	13	14		
ZPY16CT	16	17		

* Dimensions of D are the same.

Applicable Tubing

Applicable tube O.D.	P	Q	R
N4 (Nylon tube $\phi 4/2.5$)	13.5	5	1.8
N6 (Nylon tube $\phi 6/4$)	15.5	7	2.5
U4 (Soft tube $\phi 4/2.5$)	13.5	5	1.8
U6 (Soft tube $\phi 6/4$)	15.5	7	2.5

Flat/Flat with Ribs

Model	A	B	C	D	E	G: M5 x 0.8		G: M6 x 1		Y	
						F	F	Flat	Flat with ribs		
ZPY10 _U	10	12	12	22	38	5	6	3	1.7	1.8	
ZPY13 _U	13	15									
ZPY16 _U	16	18	12.5	22.5	38.5						3.5

Deep

Model	A	B	C	D	E	G: M5 x 0.8		G: M6 x 1		Y
						F	F			
ZPY10D	10	12	15	25	41	5	6	6	7	
ZPY16D	16	18	16	26	42					

Applicable Tubing

Applicable tube O.D.	P	Q	R
N4 (Nylon tube $\phi 4/2.5$)	14.5	5	1.8
N6 (Nylon tube $\phi 6/4$)	16.5	7	2.5
U4 (Soft tube $\phi 4/2.5$)	14.5	5	1.8
U6 (Soft tube $\phi 6/4$)	16.5	7	2.5

- ZA
- ZX
- ZR
- ZM
- ZMA
- ZQ
- ZH
- ZU
- ZL
- ZY□
- ZF□
- ZP□
- SP
- ZCUK
- AMJ
- AMV
- AEP
- HEP

Related Equipment

Series ZPY

Connection	Barb fitting	Pad Form	Flat/Flat with ribs/Deep/Thin flat/ Thin flat with ribs/Elliptic
Vacuum Entry Port	Lateral	Mounting	Female thread

Size/ø20, ø25, ø32

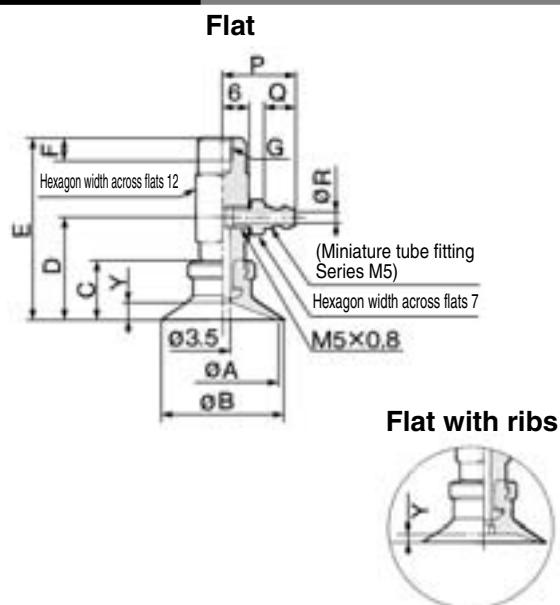

Size/ø40, ø50

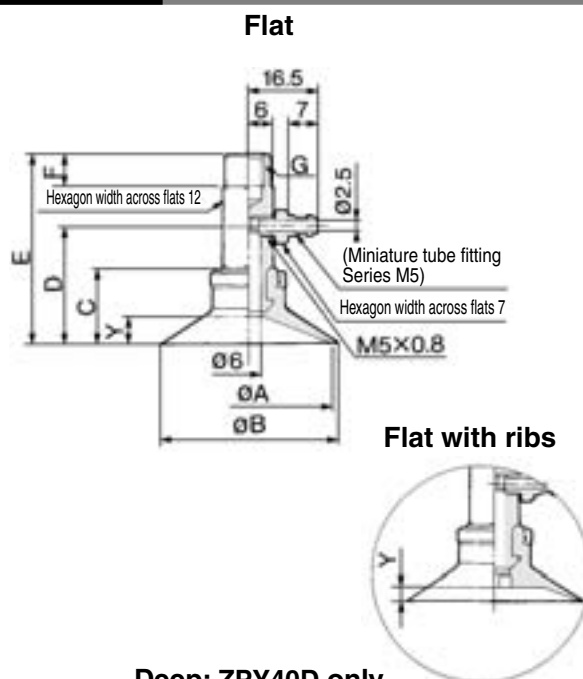

Deep: ZPY25D only

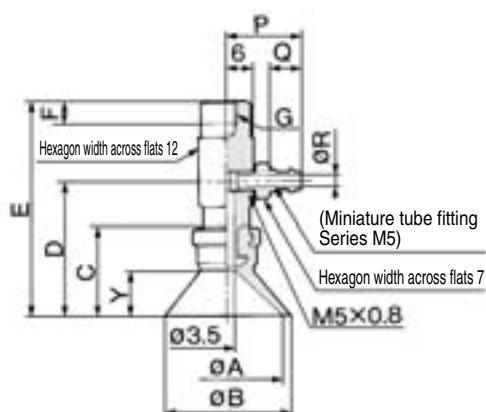

Deep: ZPY40D only

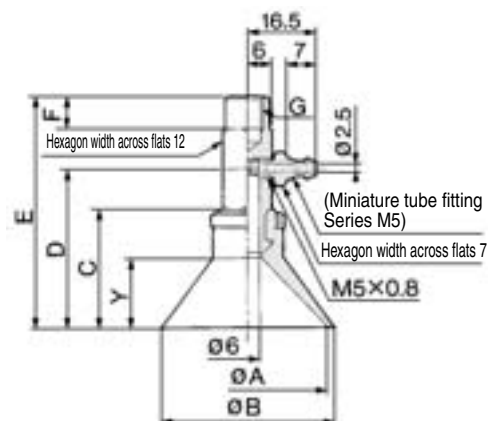

Flat/Flat with ribs

Model	A	B	C	D	E	G: M5 x 0.8	G: M6 x 1	G: M8 x 1.25	Y	
						F	F	F	Flat	Flat with ribs
ZPY20 $\frac{U}{C}$	20	23	14	24	42				4	1.7
ZPY25 $\frac{U}{C}$	25	28	14	24	42	5	6	8	4	1.8
ZPY32 $\frac{U}{C}$	32	35	14.5	24.5	42.5				4.5	2.3

Flat/Flat with ribs

Model	A	B	C	D	E	G: M6 x 1	G: M8 x 1.25	Y	
						F	F	Flat	Flat with ribs
ZPY40 $\frac{U}{C}$	40	43	18.5	28.5	46.5			6.5	3.3
ZPY50 $\frac{U}{C}$	50	53	19.5	29.5	47.5	6	8	7.5	3.8

Deep

Model	A	B	C	D	E	G: M5 x 0.8	G: M6 x 1	G: M8 x 1.25	Y
						F	F	F	
ZPY25D	25	28	20	30	48	5	6	8	10

Deep

Model	A	B	C	D	E	G: M6 x 1	G: M8 x 1.25	Y
						F	F	
ZPY40D	40	43	29	39	57	6	8	17

Applicable Tubing

Applicable tube O.D.	P	Q	R
N4 (Nylontube ø4/2.5)	14.5	5	1.8
N6 (Nylon tube ø6/4)	16.5	7	2.5
U4 (Soft tube ø4/2.5)	14.5	5	1.8
U6 (Soft tube ø6/4)	16.5	7	2.5



Vacuum Pad/ Lateral Vacuum Entry with Barb Fitting With Buffer

Series ZPY

Specifications

Vacuum entry	Direction		Lateral
	Connection		Barb fitting
Applicable tubing dia.	Elliptic (2 x 4, 3.5 x 7, 4 x 10) ø10 to ø16 (Thin section series) ø2 to ø8		ø4, ø6 Nylon tube, ø4, ø6 Urethane tube
	ø10 to ø16		ø4, ø6 Nylon tube, ø4, ø6 Urethane tube
	ø20 to ø32		ø4, ø6 Nylon tube, ø4, ø6 Urethane tube
	ø40 to ø50		ø6 Nylon tube, ø6 Urethane tube
Mounting	Thread dia.	Elliptic (2 x 4, 3.5 x 7, 4 x 10) ø10 to ø16 (Thin section series) ø2 to ø8	M8 x 1 Male thread
		ø10 to ø16	M10 x 1 Male thread
		ø20 to ø32	M10 x 1 Male thread
		ø40 to ø50	M14 x 1 Male thread



Buffer Specifications

Pad dia. (mm)	ø2 to ø8*	ø10 to ø32	ø40, ø50
Stroke (mm)	6, 10, 15, 25	10, 20, 30, 40, 50	10, 20, 30, 50
Spring Reactive Force (N)	0 stroke	0.8	1.0
	Full stroke	1.2	3.0
Non-rotating specification		Rotating (J)/Non-rotating (K)	

* Refer to ø2 to ø8 for Thin flat, Thin flat with ribs and Elliptic.

Pad Type

Pad form	Flat	Flat with ribs	Deep	Bellows	Thin flat/Thin flat with ribs
Pad dia. (mm)	2, 4, 6, 8, 2 x 4, 3.5 x 7, 4 x 10, 10, 13, 16, 20, 25, 32, 40, 50	10, 13, 16, 20, 25, 32, 40, 50	10, 16, 25, 40	6, 8, 10, 13, 16, 20, 25, 32, 40, 50	10, 13, 16
Material (Color)	NBR (Black), Silicon rubber (White), Urethane rubber (Brown), Fluororubber (Black with green mark) Conductive NBR (Black with one silver mark), Conductive silicon rubber (Black with two silver marks)				
Durometer	NBR (50°), Silicon rubber (40°), Urethane rubber/Fluororubber (60°) Conductive NBR (50°), Conductive silicon rubber (50°)				

Mass

(g)

Stroke (mm)	Pad form		Flat/ Flat with ribs	Deep	Bellows
	Model				
6	ZPY2004	10 to 16	33	—	33
	ZPY3507				
	ZPY4010				
	ZPY02 to 08				
	ZPY10 to 16 (Thin section series)				
10	ZPY 10	20 to 16	45	45	46
	ZPY 20				
10	ZPY 20	25	50	51	53
	ZPY 32				
10	ZPY 40	50	115	117	127
	ZPY 50				
			132	—	134

Mass by Stroke

(g)

Stroke (mm)	Model						
	10	15	20	25	30	40	50
ZPY02 to 08	+7	+8	—	+9	—	—	—
ZPY10 to 25	—	—	+12	—	+14	+26	+28
ZPY40, 50	—	—	-5.5	—	-1.5	—	+30

How to Order

Series ZPY
With buffer

ZPY 16 U GS K 20 - U6 - A10

Pad diameter (mm)

2004	2 x 4
3507	3.5 x 7
4010	4 x 10
02	2
04	4
06	6
08	8
10	10
13	13
16	16
20	20
25	25
32	32
40	40
50	50



(Refer to "Table (1)" for applications.)

Pad type

U	Flat
C	Flat with ribs
D	Deep
B	Bellows
UT	Thin flat
CT	Thin flat with ribs

Material

N	NBR
S	Silicon rubber
U	Urethane rubber
F	Fluororubber
GN	Conductive NBR
GS	Conductive silicon rubber

Buffer type

J	Rotating
K	Non-rotating

Buffer stroke



(Refer to "Table (2)" for applications.)

Vacuum entry port



(Refer to "Table (3)" for applications.)

Mounting thread/Male thread



(Refer to "Table (3)" for applications.)

Table (1) Pad Diameter/Pad Type

Dia. (mm) \ Type	2 x 4	3.5 x 7	4 x 10	2	4	6	8	10	13	16	20	25	32	40	50
Flat	●	●	●	●	●	●	●	●	●	●	●	●	●	●	●
Flat with ribs	—	—	—	—	—	—	—	●	●	●	●	●	●	●	●
Deep	—	—	—	—	—	—	—	●	—	●	—	●	—	●	—
Bellows	—	—	—	—	—	●	●	●	●	●	●	●	●	●	●
Thin flat	—	—	—	—	—	—	—	●	●	●	—	—	—	—	—
Thin flat with ribs	—	—	—	—	—	—	—	●	●	●	—	—	—	—	—

Table (2) Pad Diameter/Stroke

Dia. (mm) \ Stroke	2 x 4	3.5 x 7	4 x 10	2	4	6	8	Thin flat/Thin flat with ribs			10	13	16	20	25	32	40	50
								10	13	16								
6 mm	●	●	●	●	●	●	●	●	●	●	—	—	—	—	—	—	—	—
10 mm	●	●	●	●	●	●	●	●	●	●	●	●	●	●	●	●	●	●
15 mm	●	●	●	●	●	●	●	●	●	●	—	—	—	—	—	—	—	—
20 mm	—	—	—	—	—	—	—	—	—	—	●	●	●	●	●	●	●	●
25 mm	●	●	●	●	●	●	●	●	●	●	—	—	—	—	—	—	—	—
30 mm	—	—	—	—	—	—	—	—	—	—	●	●	●	●	●	●	●	●
40 mm	—	—	—	—	—	—	—	—	—	—	●	●	●	●	●	●	—	—
50 mm	—	—	—	—	—	—	—	—	—	—	●	●	●	●	●	●	●	●

Table (3) Vacuum Entry/Mounting Thread Diameter

	Symbol	Thread dia./ Port size	ø2 to ø8 2 x 4, 3.5 x 7 4 x 10 ø10 to ø16 (Thin section series)	ø10 to ø32	ø40, ø50
			Vacuum entry	One-touch fitting	N4
		N6	ø6 Nylon tube	●	●
		U4	ø4 Urethane tube	●	●
		U6	ø6 Urethane tube	●	●
Mounting	Male thread	A8	M8 x 1	●	—
		A10	M10 x 1	—	●
		A14	M14 x 1	—	—

Tightening Torque

(N·m)

Mounting thread diameter	Torque
M8 x 1	2.0 ±0.5
M10 x 1	3.0 ±0.5
M14 x 1	7.0 ±0.5

ZA

ZX

ZR

ZM

ZMA

ZQ

ZH

ZU

ZL

ZY□

ZF□

ZP□

SP

ZCUK

AMJ

AMV

AEP

HEP

Related
Equipment

Series ZPY

Connection	Barb fitting	Pad Form	Flat/Flat with ribs/Deep
Vacuum Entry Port	Lateral	Mounting	Male thread

Flat/Flat with ribs/ø20, ø25, ø32

Deep/ø25

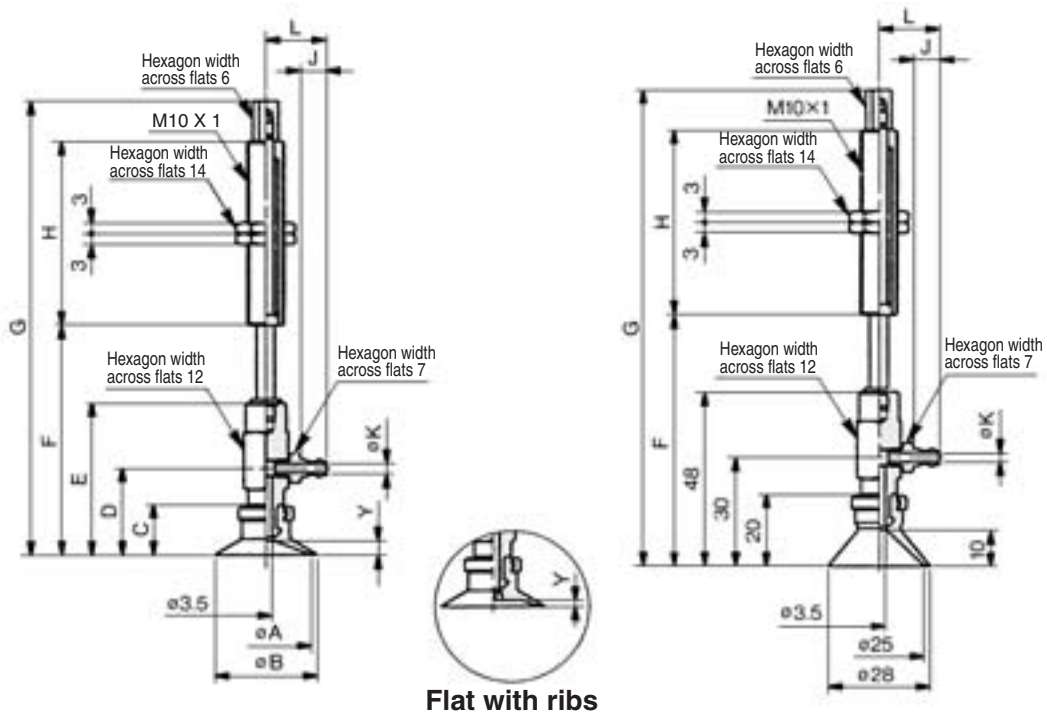

ø20, ø25, ø32

Flat/Flat with Ribs

Model	A	B	C	D	E	Y	
						Flat	Flat with ribs
ZPY20 _C □□□□□□□□-□□A10	20	23	14	24	42	4	1.7
ZPY25 _C □□□□□□□□-□□A10	25	28					1.8
ZPY32 _C □□□□□□□□-□□A10	32	35	14.5	24.5	42.5	4.5	2.3

Dimensions by Stroke

Model	ø20, ø25		ø32		H
	F	G	F	G	
ZPY□□□□□□□□□□□□□□-□□A10	53	87	53.5	87.5	23
ZPY□□□□□□□□□□□□□□-□□A10	63	125	63.5	125.5	51
ZPY□□□□□□□□□□□□□□-□□A10	73	135	73.5	135.5	
ZPY□□□□□□□□□□□□□□-□□A10	83	171	83.5	171.5	77
ZPY□□□□□□□□□□□□□□-□□A10	93	181	93.5	181.5	

ø25

Deep

Model	F	G	H
ZPY25D□□□□□□□□□□□□□□-□□A10	59	93	23
ZPY25D□□□□□□□□□□□□□□-□□A10	69	131	51
ZPY25D□□□□□□□□□□□□□□-□□A10	79	141	
ZPY25D□□□□□□□□□□□□□□-□□A10	89	177	77
ZPY25D□□□□□□□□□□□□□□-□□A10	99	187	

Dimensions by Tubing

Model	J	K	L
ZPY□□□□□□□□□□□□□□-□□A10	5	1.8	14.5
ZPY□□□□□□□□□□□□□□-□□A10	7	2.5	16.5

Vacuum Pad/
Lateral Vacuum Entry with Barb Fitting with Buffer **Series ZPY**

Connection	Barb fitting	Pad Form	Flat/Flat with ribs/Deep
Vacuum Entry Port	Lateral	Mounting	Male thread

Flat/Flat with ribs/ø40, ø50

Deep/ø40

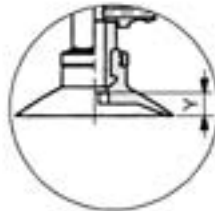
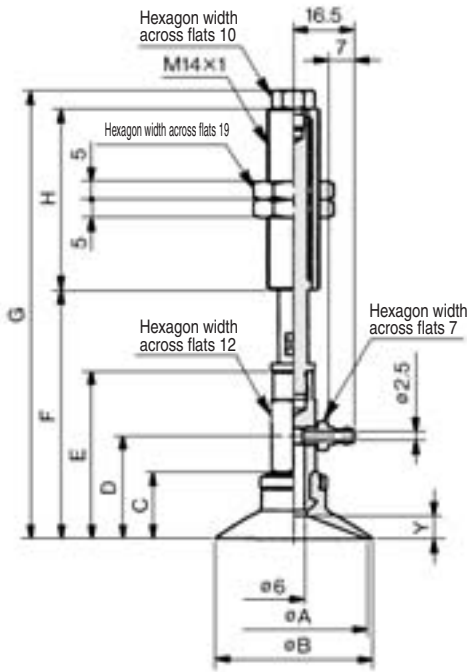

Flat with ribs

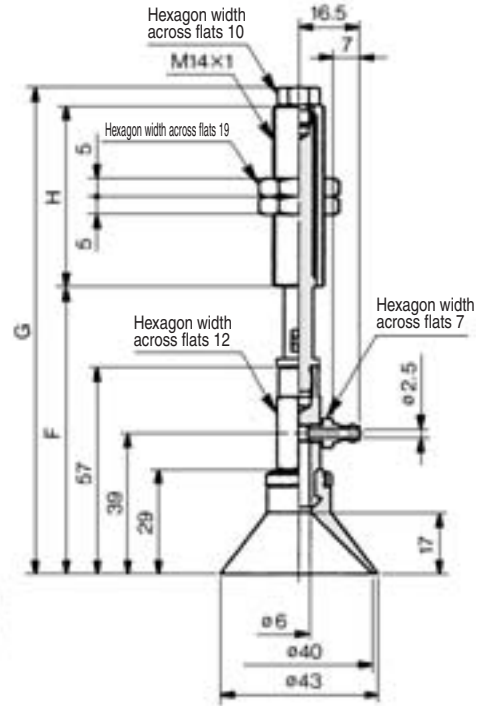

ø40, ø50

Flat/Flat with Ribs

Model	A	B	C	D	E	Y	
						Flat	Flat with ribs
ZPY40 ^U _C □□□□□□□□□□6-A14	40	43	18.5	28.5	46.5	6.5	3.3
ZPY50 ^U _C □□□□□□□□□□6-A14	50	53	19.5	29.5	47.5	7.5	3.8

Dimensions by Stroke

Model	ø40		ø50		H
	F	G	F	G	
ZPY□□ ^U _C □□□□□□□□□□6-A14	58.5	126.5	59.5	127.5	50
ZPY□□ ^U _C □□□□□□□□□□6-A14	68.5	123.5	69.5	124.5	
ZPY□□ ^U _C □□□□□□□□□□6-A14	78.5	133.5	79.5	134.5	
ZPY□□ ^U _C □□□□□□□□□□6-A14	98.5	178.5	99.5	179.5	

ø40

Deep

Model	F	G	H
ZPY40D□□□□□□□□□□6-A14	69	137	50
ZPY40D□□□□□□□□□□6-A14	79	134	
ZPY40D□□□□□□□□□□6-A14	89	144	
ZPY40D□□□□□□□□□□6-A14	109	189	75

- ZA
- ZX
- ZR
- ZM
- ZMA
- ZQ
- ZH
- ZU
- ZL
- ZY□
- ZF□
- ZP□
- SP
- ZCUK
- AMJ
- AMV
- AEP
- HEP
- Related Equipment

Vacuum Pad/Components

 Refer to pages 1182 to 1187 for part numbers of ③ to ⑥.

Construction

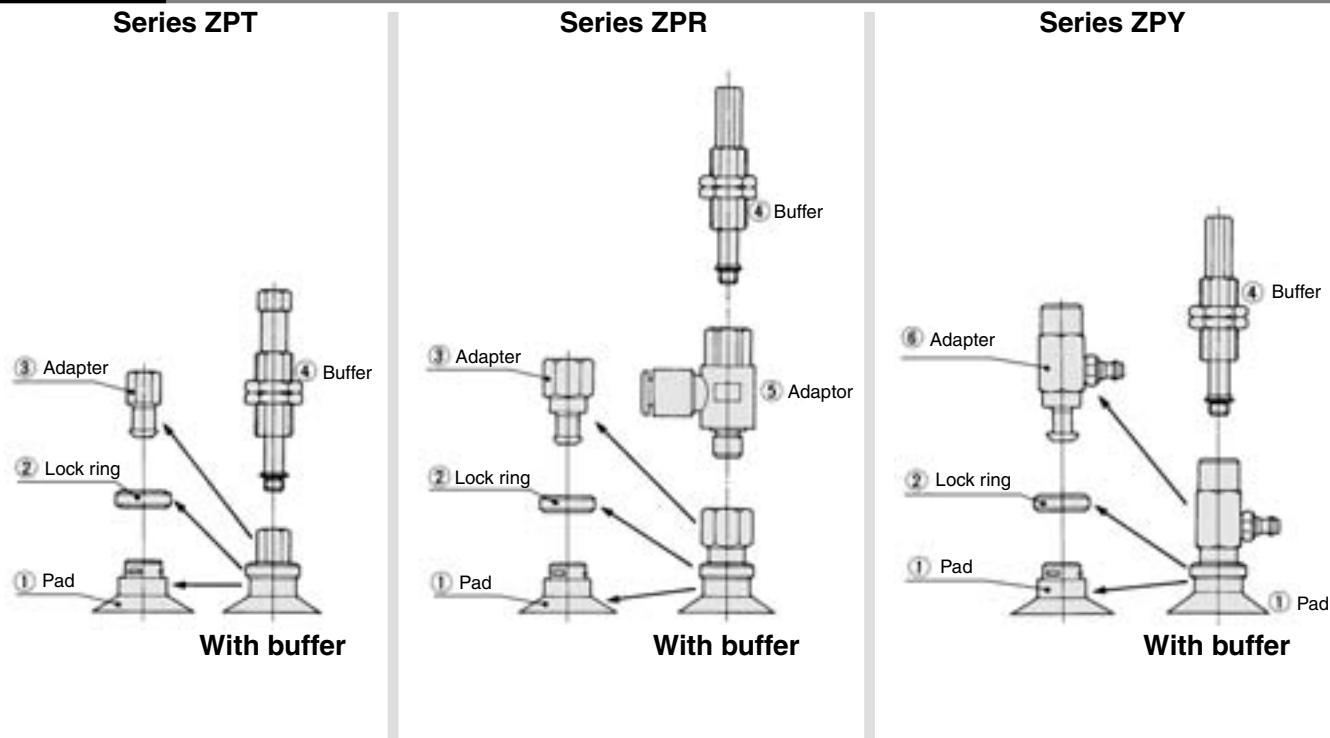

Component Parts

No.	Description	Material	Note
1	Pad	Conductive NBR, Conductive silicon rubber, NBR, Silicon rubber, Urethane rubber, Fluoro rubber	
2	Lock ring	Brass	Electroless nickel plated
3	Adapter	Brass	Electroless nickel plated
4	Buffer	Brass	Electroless nickel plated
5	Adapter (with one-touch fitting)	Brass, PBT	Electroless nickel plated
6	Adapter (with barb fitting)	Brass	Electroless nickel plated

Maintenance of Pad

Since pads are essentially rubber, deterioration is unavoidable. The rate of deterioration depends upon factors such as conditions of use, environment and temperature. Regular maintenance should be performed. If any damage, splitting, cracking or abrasion has occurred in a pad which appears to be harmful, replace it immediately. Also, take care not to damage the outside surface of the pad.

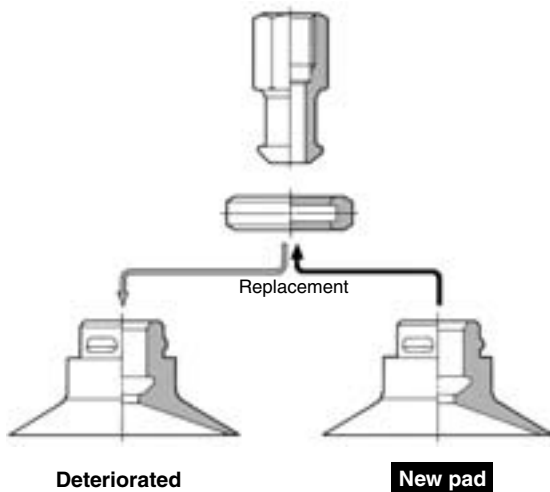

How to Replace

1. Pull the lock ring upward, and after lifting it to the adapter, remove the old pad by pulling it downward.
2. While holding the lock ring in the raised position, place a new pad onto the adapter.
3. Confirm that the pad is securely in place, and then return the lock ring to its original position.

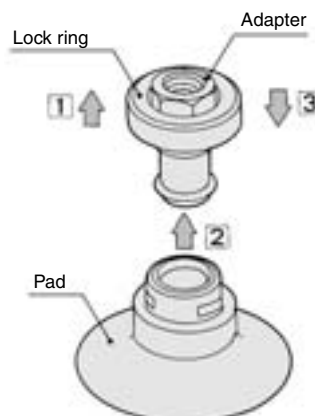

Replacement Parts: Pad Unit (With lock ring/Without lock ring)

How to Order Pad Unit

How to Order Lock Ring Unit

ZP 10 U N - X19

ZPL 1

Pad dia. (mm)

02	2
04	4
06	6
08	8
10	10
13	13
16	16
20	20
25	25
32	32
40	40
50	50

Lock ring

Nil	With lock ring
-X19	Without lock ring (ø10 or larger)

Material

N	NBR
S	Silicon rubber
U	Urethane rubber
F	Fluororubber
GN	Conductive NBR
GS	Conductive silicon rubber

Pad type

U	Flat
C	Flat with ribs
D	Deep
B	Bellows

Applicable pad dia. (mm)

1	10 to 16
2	20 to 32
3	40, 50

Flat (U) Refer to page 1181 for the Elliptic.

ZP02U□ to 08U□

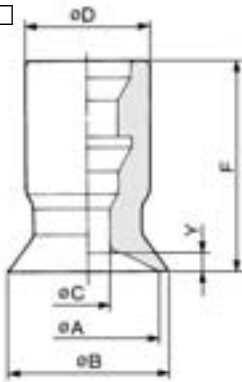

ZP10U□ to 50U□

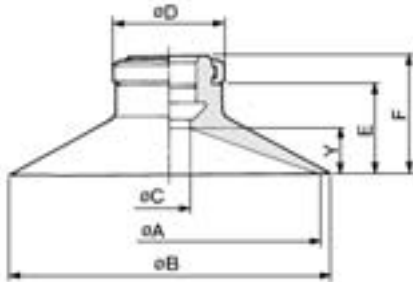

Model	Size	A	B	C	D	E	F	Y
ZP02U□	U02	2	2.6	1.2	7	—	12	0.5
ZP04U□	U04	4	4.8	1.6	7	—	12	0.8
ZP06U□	U06	6	7	2.5	7	—	12	0.8
ZP08U□	U08	8	9	2.5	7	—	12	1
ZP10U□	U10	10	12	4	13	7.7	12	3
ZP13U□	U13	13	15	4	13	7.7	12	3
ZP16U□	U16	16	18	4	13	8.2	12.5	3.5
ZP20U□	U20	20	23	4	15	9.5	14	4
ZP25U□	U25	25	28	4	15	9.5	14	4
ZP32U□	U32	32	35	4	15	10	14.5	4.5
ZP40U□	U40	40	43	7	18	13.7	18.5	6.5
ZP50U□	U50	50	53	7	18	14.7	19.5	7.5

* Put in the symbol for material at the end of model no.

Flat with Ribs (C)

ZP10C□ to 50C□

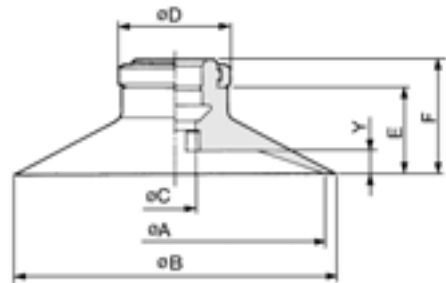

Model	Size	A	B	C	D	E	F	Y
ZP10C□	C10	10	12	4	13	7.7	12	1.7
ZP13C□	C13	13	15	4	13	7.7	12	1.8
ZP16C□	C16	16	18	4	13	8.2	12.5	1.2
ZP20C□	C20	20	23	4	15	9.5	14	1.7
ZP25C□	C25	25	28	4	15	9.5	14	1.8
ZP32C□	C32	32	35	4	15	10	14.5	2.3
ZP40C□	C40	40	43	7	18	13.7	18.5	3.3
ZP50C□	C50	50	53	7	18	14.7	19.5	3.8

Deep (D)

ZP10D□ to 40D□

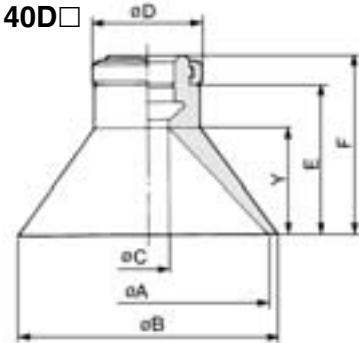

Model	Size	A	B	C	D	E	F	Y
ZP10D□	D10	10	12	4	13	10.7	15	6
ZP16D□	D16	16	18	4	13	11.7	16	7
ZP25D□	D25	25	28	4	15	15.5	20	10
ZP40D□	D40	40	43	7	18	24.2	29	17

- ZA
- ZX
- ZR
- ZM
- ZMA
- ZQ
- ZH
- ZU
- ZL
- ZY□
- ZF□
- ZP□
- SP
- ZCUK
- AMJ
- AMV
- AEP
- HEP

Related Equipment

Series ZP

Replacement Parts: Pad Unit (With lock ring/Without lock ring)

Bellows (B)/With Lock Ring

Pad diameter: $\phi 6$ to $\phi 8$
ZP06B□ to 08B□

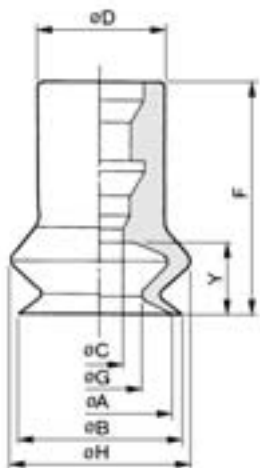

Buffer Mounting Nut

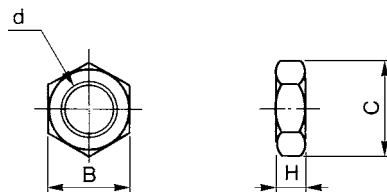

Model	d	H	B	C
ZPNA-M5	M5 x 0.8	4	8	9.2
ZPNA-M6	M6 x 1	3	8	9.2
ZPNA-M8	M8 x 1	3	12	13.9
ZPNA-M10	M10 x 1	3	14	16.2
ZPNA-M14	M14 x 1	5	19	21.9

Pad diameter: $\phi 10$ to $\phi 50$
ZP10B□ to 50B□

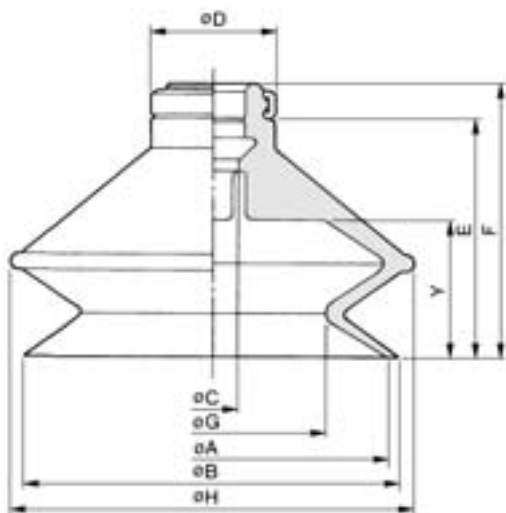

Model	Size	A	B	C	D	E	F	G	H	Y
ZP06B□	B06	6	7	2.5	7	—	13	3.3	9	4
ZP08B□	B08	8	9	2.5	7	—	13	4.7	10	4
ZP10B□	B10	10	12	4	13	11.7	16	6	14	5.5
ZP13B□	B13	13	15	4	13	14.2	18.5	9	19	7.5
ZP16B□	B16	16	18	4	13	15.7	20	10	21	8.5
ZP20B□	B20	20	22	4	15	19	23.5	12	25	10.5
ZP25B□	B25	25	27	4	15	19.5	24	16	28	10.5
ZP32B□	B32	32	34	4	15	24.5	29	19	37	14
ZP40B□	B40	40	43	7	18	29.2	34	24	48	16
ZP50B□	B50	50	53	7	18	33.2	38	32	57	19

* Put in the symbol for material at the end of model no.

Replacement Parts: Pad Unit (With lock ring/Without lock ring)

How to Order/Pad Unit

Thin flat (UT), Thin flat with ribs (CT)

ZP 10 UT N

Pad diameter

10	10
13	13
16	16

Pad type

UT	Thin flat
CT	Thin flat with ribs

Material

N	NBR
S	Silicon rubber
U	Urethane rubber
F	Fluororubber
GN	Conductive NBR
GS	Conductive silicon rubber

Dimensions

Thin flat

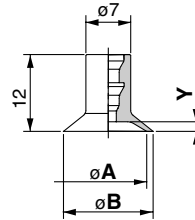

ZP□□UT□□

Thin flat with ribs

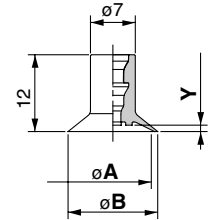

ZP□□CT□□

Dimensions (mm)

Model	A	B	Y
ZP10UT□□	10	11	1
ZP13UT□□	13	14	1.5
ZP16UT□□	16	17	

Dimensions (mm)

Model	A	B	Y
ZP10CT□□	10	11	0.8
ZP13CT□□	13	14	1
ZP16CT□□	16	17	

Elliptic

ZP 2004 U N

Pad diameter (Breadth x Length)

2004	2 x 4
3507	3.5 x 7
4010	4 x 10

Pad type

U	Flat
---	------

Material

N	NBR
S	Silicon rubber
U	Urethane rubber
F	Fluororubber
GN	Conductive NBR
GS	Conductive silicon rubber

Dimensions

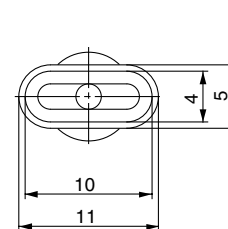
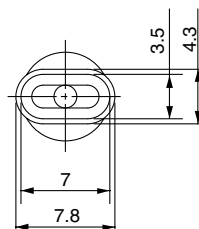
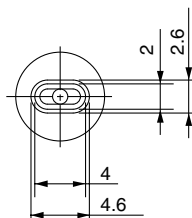
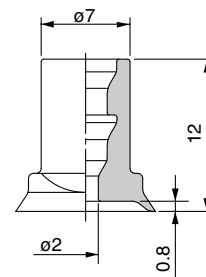
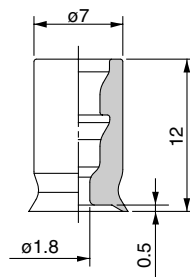
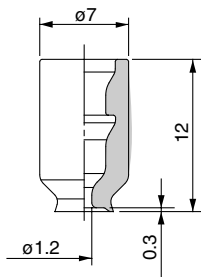

ZP2004U□□

ZP3507U□□

ZP4010U□□

- ZA
- ZX
- ZR
- ZM
- ZMA
- ZQ
- ZH
- ZU
- ZL
- ZY□
- ZF□
- ZP□
- SP
- ZCUK
- AMJ
- AMV
- AEP
- HEP

Related Equipment

Series ZP

Replacement Parts: Adapter/Buffer (Series ZPT)

Appropriate adaptor or buffer can be selected for the currently used pad model.

● Without buffer

— The same symbol

←···· Replacement of the symbol

[Pad model no.]

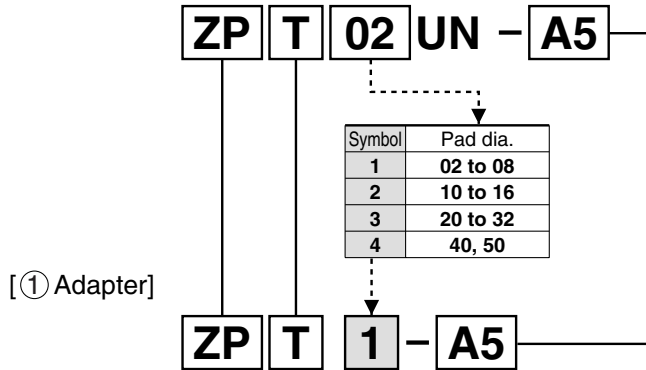

Construction

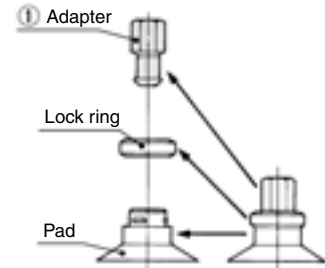

Applicable pad diameter: $\phi 2$ to $\phi 8$

2 x 4, 3.5 x 7, 4 x 10
 $\phi 10$ to $\phi 16$ (Thin section series)

Model	① Adapter
ZPT□□□□-A5	ZPT1-A5
ZPT□□□□-A6	ZPT1-A6
ZPT□□□□-B4	ZPT1-B4
ZPT□□□□-B5	ZPT1-B5

Applicable pad diameter: $\phi 10$ to $\phi 16$

Model	① Adapter
ZPT□□□□-A5	ZPT2-A5
ZPT□□□□-A6	ZPT2-A6
ZPT□□□□-B5	ZPT2-B5
ZPT□□□□-B6	ZPT2-B6
ZPT□□□□-B01	ZPT2-B01
ZPT□□□□-N01	ZPT2-N01
ZPT□□□□-T01	ZPT2-T01

Applicable pad diameter: $\phi 20$ to $\phi 32$

Model	① Adapter
ZPT□□□□-A6	ZPT3-A6
ZPT□□□□-A8	ZPT3-A8
ZPT□□□□-B5	ZPT3-B5
ZPT□□□□-B6	ZPT3-B6
ZPT□□□□-B8	ZPT3-B8
ZPT□□□□-B01	ZPT3-B01
ZPT□□□□-N01	ZPT3-N01
ZPT□□□□-T01	ZPT3-T01

Applicable pad diameter: $\phi 40$, $\phi 50$

Model	① Adapter
ZPT□□□□-A6	ZPT4-A6
ZPT□□□□-A8	ZPT4-A8
ZPT□□□□-B6	ZPT4-B6
ZPT□□□□-B8	ZPT4-B8
ZPT□□□□-B01	ZPT4-B01
ZPT□□□□-N01	ZPT4-N01
ZPT□□□□-T01	ZPT4-T01

Replacement Parts: Adapter/Buffer (Series ZPT)

● With buffer

— The same symbol
 ← Replacement of the symbol

Construction

[Pad model no.]

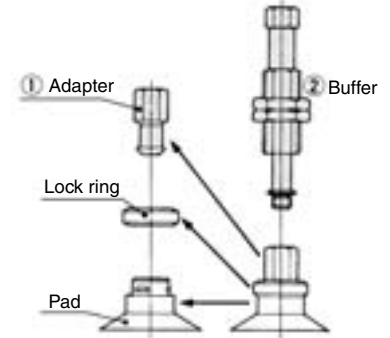
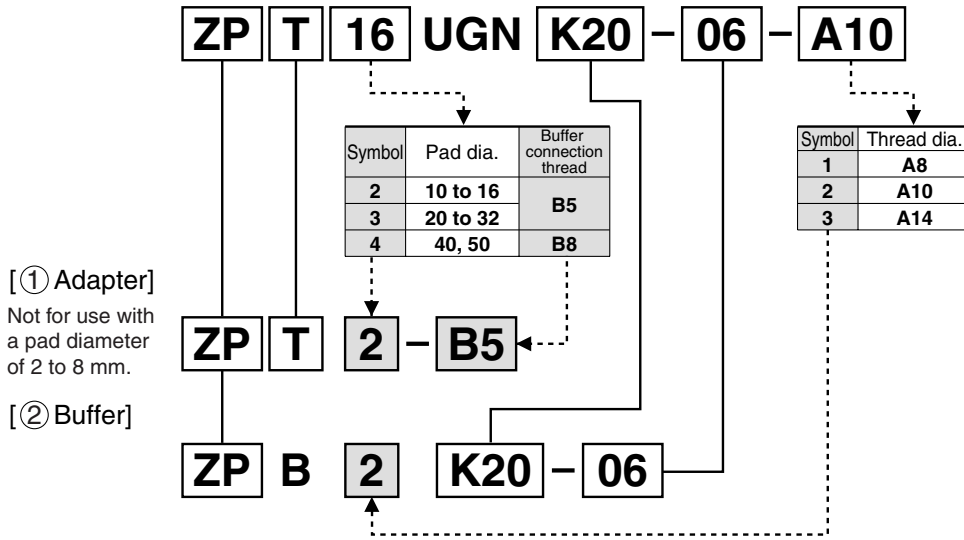

[① Adapter]
 Not for use with a pad diameter of 2 to 8 mm.

[② Buffer]

* Refer to ø2 to ø8 for Thin flat, Thin flat with ribs, and Elliptic.

Applicable pad diameter: ø2 to ø8
 2 x 4, 3.5 x 7, 4 x 10
 ø10 to ø16 (Thin section series)

Model	② Buffer only
ZPT□□□□(J-K)★★-B3-A8	ZPB1(J-K)★★-B3
ZPT□□□□(J-K)★★-B5-A8	ZPB1(J-K)★★-B5
ZPT□□□□(J-K)★★-N4-A8	ZPB1(J-K)★★-N4
ZPT□□□□(J-K)★★-U4-A8	ZPB1(J-K)★★-U4
ZPT□□□□(J-K)★★-04-A8	ZPB1(J-K)★★-04
ZPT□□□□(J-K)★★-06-A8	ZPB1(J-K)★★-06

Note) Applicable buffer stroke (★★): 6, 10, 15, 25 mm

Applicable pad diameter: ø10 to ø16

Model	① Adapter	② Buffer
ZPT□□□□(J-K)★★-B5-A10	ZPT2-B5	ZPB2(J-K)★★-B5
ZPT□□□□(J-K)★★-N6-A10	ZPT2-B5	ZPB2(J-K)★★-N6
ZPT□□□□(J-K)★★-U6-A10	ZPT2-B5	ZPB2(J-K)★★-U6
ZPT□□□□(J-K)★★-04-A10	ZPT2-B5	ZPB2(J-K)★★-04
ZPT□□□□(J-K)★★-06-A10	ZPT2-B5	ZPB2(J-K)★★-06

Note) Applicable buffer stroke (★★): 10, 20, 30, 40, 50 mm

Applicable pad diameter: ø20 to ø32

Model	① Adapter	② Buffer
ZPT□□□□(J-K)★★-B5-A10	ZPT3-B5	ZPB2(J-K)★★-B5
ZPT□□□□(J-K)★★-N6-A10	ZPT3-B5	ZPB2(J-K)★★-N6
ZPT□□□□(J-K)★★-U6-A10	ZPT3-B5	ZPB2(J-K)★★-U6
ZPT□□□□(J-K)★★-04-A10	ZPT3-B5	ZPB2(J-K)★★-04
ZPT□□□□(J-K)★★-06-A10	ZPT3-B5	ZPB2(J-K)★★-06

Note) Applicable buffer stroke (★★): 10, 20, 30, 40, 50 mm

Applicable pad diameter: ø40, ø50

Model	① Adapter	② Buffer
ZPT□□□□(J-K)★★-B5-A14	ZPT4-B8	ZPB3(J-K)★★-B5
ZPT□□□□(J-K)★★-□01-A14	ZPT4-B8	ZPB3(J-K)★★-□01
ZPT□□□□(J-K)★★-N6-A14	ZPT4-B8	ZPB3(J-K)★★-N6
ZPT□□□□(J-K)★★-U6-A14	ZPT4-B8	ZPB3(J-K)★★-U6
ZPT□□□□(J-K)★★-06-A14	ZPT4-B8	ZPB3(J-K)★★-06
ZPT□□□□(J-K)★★-08-A14	ZPT4-B8	ZPB3(J-K)★★-08

Note) Applicable buffer stroke (★★): 10, 20, 30, 50 mm

- ZA
- ZX
- ZR
- ZM
- ZMA
- ZQ
- ZH
- ZU
- ZL
- ZY□
- ZF□
- ZP□
- SP
- ZCUK
- AMJ
- AMV
- AEP
- HEP

Related Equipment

Replacement Parts: Adapter/Buffer (Series ZPR)

● Without buffer

— The same symbol

← Replacement of the symbol

[Pad model no.]

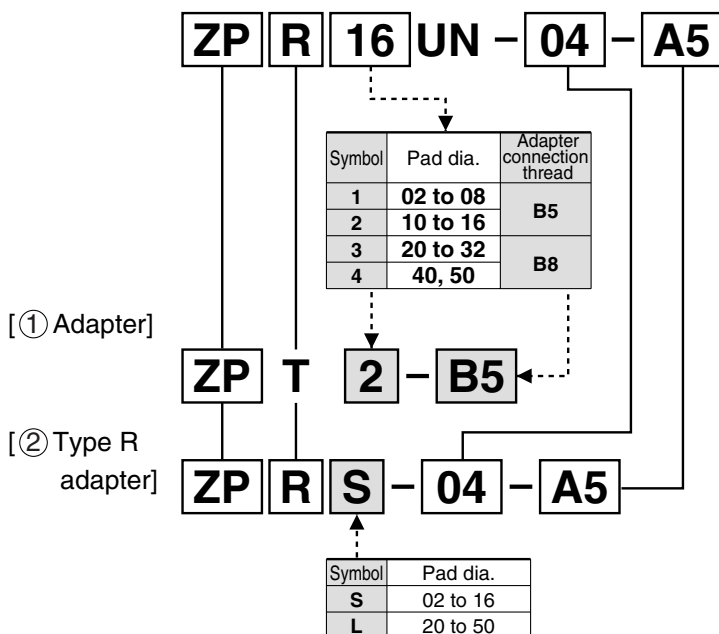

Construction

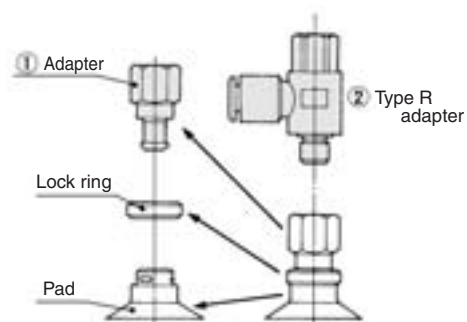

Applicable pad diameter: $\varnothing 2$ to $\varnothing 8$

2 x 4, 3.5 x 7, 4 x 10

$\varnothing 10$ to $\varnothing 16$ (Thin section series)

Model	① Type T adapter	② Type R adapter
ZPR□□□□-☆☆-A5	ZPT1-B5	ZPRS-☆☆-A5
ZPR□□□□-☆☆-A6	ZPT1-B5	ZPRS-☆☆-A6
ZPR□□□□-☆☆-B4	ZPT1-B5	ZPRS-☆☆-B4
ZPR□□□□-☆☆-B5	ZPT1-B5	ZPRS-☆☆-B5

Note) Vacuum entry (☆☆): 04, 06

Applicable pad diameter: $\varnothing 10$ to $\varnothing 16$

Model	① Type T adapter	② Type R adapter
ZPR□□□□-☆☆-A5	ZPT2-B5	ZPRS-☆☆-A5
ZPR□□□□-☆☆-A6	ZPT2-B5	ZPRS-☆☆-A6
ZPR□□□□-☆☆-B5	ZPT2-B5	ZPRS-☆☆-B5
ZPR□□□□-☆☆-B6	ZPT2-B5	ZPRS-☆☆-B6

Note) Vacuum entry (☆☆): 04, 06

Applicable pad diameter: $\varnothing 20$ to $\varnothing 32$

Model	① Type T adapter	② Type R adapter
ZPR□□□□-☆☆-A6	ZPT3-B8	ZPRL-☆☆-A6
ZPR□□□□-☆☆-A8	ZPT3-B8	ZPRL-☆☆-A8
ZPR□□□□-☆☆-B5	ZPT3-B8	ZPRL-☆☆-B5
ZPR□□□□-☆☆-B6	ZPT3-B8	ZPRL-☆☆-B6
ZPR□□□□-☆☆-B8	ZPT3-B8	ZPRL-☆☆-B8

Note) Vacuum entry (☆☆): 04, 06, 08

Applicable pad diameter: $\varnothing 40$, $\varnothing 50$

Model	① Type T adapter	② Type R adapter
ZPR□□□□-☆☆-A6	ZPT4-B8	ZPRL-☆☆-A6
ZPR□□□□-☆☆-A8	ZPT4-B8	ZPRL-☆☆-A8
ZPR□□□□-☆☆-B6	ZPT4-B8	ZPRL-☆☆-B6
ZPR□□□□-☆☆-B8	ZPT4-B8	ZPRL-☆☆-B8

Note) Vacuum entry (☆☆): 06, 08

Replacement Parts: Adapter/Buffer (Series ZPR)

● With buffer

— The same symbol

←···· Replacement of the symbol

Construction

[Pad model no.]

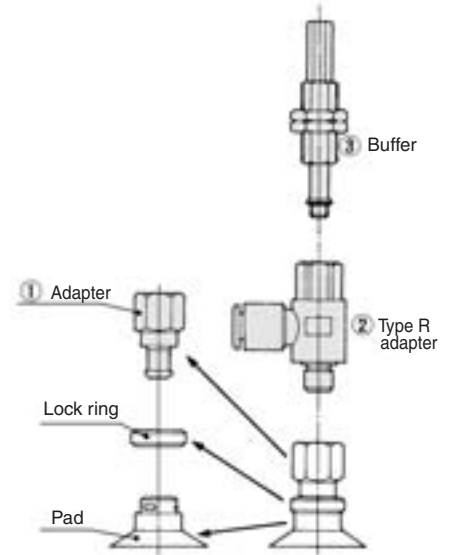
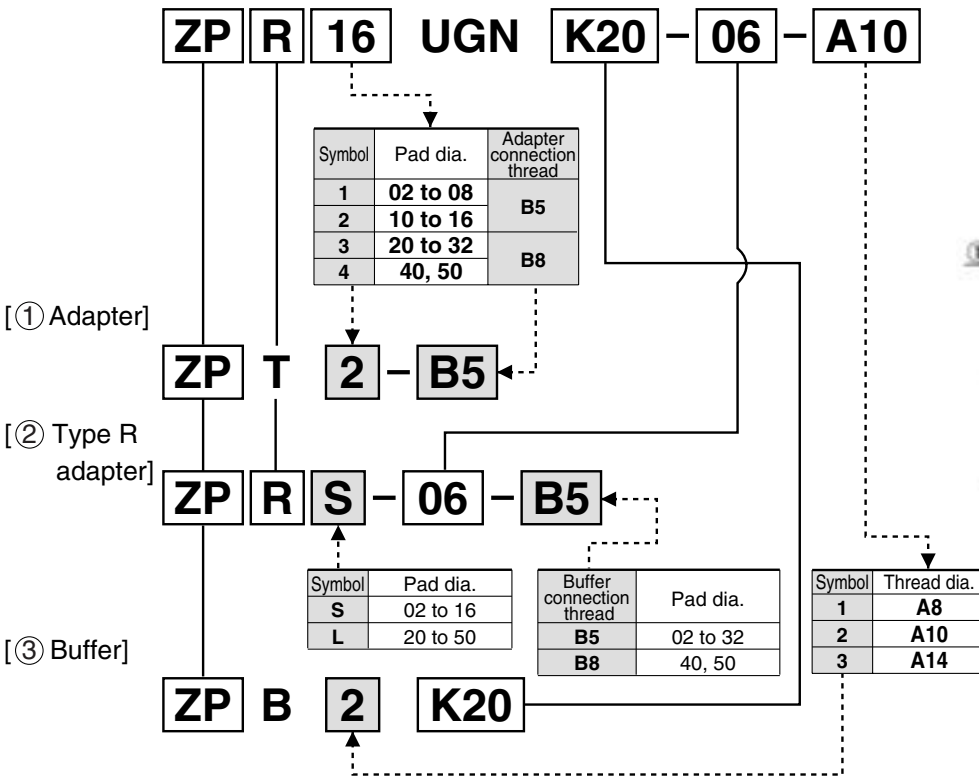

* Refer to ø2 to ø8 for Thin flat, Thin flat with ribs, and Elliptic.

Applicable pad diameter: ø2 to ø8
 2 x 4, 3.5 x 7, 4 x 10
 ø10 to ø16 (Thin section series)

Model	① Type T adapter	② Type R adapter	③ Buffer
ZPR□□□□(J-K)★★-☆☆-A8	ZPT1-B5	ZPRS-☆☆-B5	ZPB1(J-K)★★

Note 1) Applicable buffer stroke (★★): 6, 10, 15, 25 mm
 Note 2) Vacuum entry (☆☆): 04, 06

Applicable pad diameter: ø10 to ø16

Model	① Type T adapter	② Type R adapter	③ Buffer
ZPR□□□□(J-K)★★-☆☆-A10	ZPT2-B5	ZPRS-☆☆-B5	ZPB2(J-K)★★

Note 1) Applicable buffer stroke (★★): 10, 20, 30, 40, 50 mm
 Note 2) Vacuum entry (☆☆): 04, 06

Applicable pad diameter: ø20 to ø32

Model	① Type T adapter	② Type R adapter	③ Buffer
ZPR□□□□(J-K)★★-☆☆-A10	ZPT3-B8	ZPRL-☆☆-B5	ZPB2(J-K)★★

Note 1) Applicable buffer stroke (★★): 10, 20, 30, 40, 50 mm
 Note 2) Vacuum entry (☆☆): 04, 06, 08

Applicable pad diameter: ø40, ø50

Model	① Type T adapter	② Type R adapter	③ Buffer
ZPR□□□□(J-K)★★-☆☆-A14	ZPT4-B8	ZPRL-☆☆-B8	ZPB3(J-K)★★

Note 1) Applicable buffer stroke (★★): 10, 20, 30, 50 mm
 Note 2) Vacuum entry (☆☆): 06, 08

- ZA
- ZX
- ZR
- ZM
- ZMA
- ZQ
- ZH
- ZU
- ZL
- ZY□
- ZF□
- ZP□
- SP
- ZCUK
- AMJ
- AMV
- AEP
- HEP
- Related Equipment

Series ZP

Replacement Parts: Adapter/Buffer (Series ZPY)

● Without buffer

— The same symbol

←···· Replacement of the symbol

[Pad model no.]

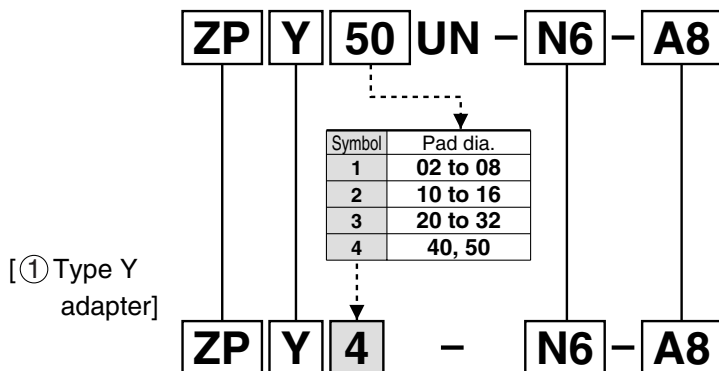

Construction

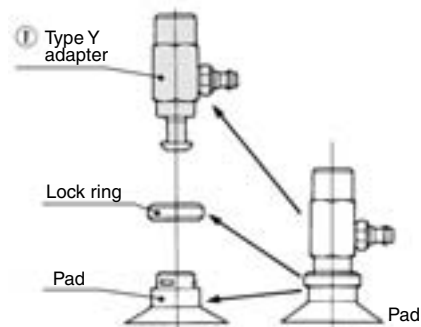

Applicable pad diameter: $\varnothing 2$ to $\varnothing 8$

2 x 4, 3.5 x 7, 4 x 10

$\varnothing 10$ to $\varnothing 16$ (Thin section series)

Model	① Adapter
ZPY□□□□-◆◆-A5	ZPY1-◆◆-A5
ZPY□□□□-◆◆-A6	ZPY1-◆◆-A6
ZPY□□□□-◆◆-B4	ZPY1-◆◆-B4
ZPY□□□□-◆◆-B5	ZPY1-◆◆-B5

Note) Vacuum entry (◆◆): N4, N6, U4, U6

Applicable pad diameter: $\varnothing 10$ to $\varnothing 16$

Model	① Adapter
ZPY□□□□-◆◆-A5	ZPY2-◆◆-A5
ZPY□□□□-◆◆-A6	ZPY2-◆◆-A6
ZPY□□□□-◆◆-B5	ZPY2-◆◆-B5
ZPY□□□□-◆◆-B6	ZPY2-◆◆-B6

Note) Vacuum entry (◆◆): N4, N6, U4, U6

Applicable pad diameter: $\varnothing 20$ to $\varnothing 32$

Model	① Adapter
ZPY□□□□-◆◆-A6	ZPY3-◆◆-A6
ZPY□□□□-◆◆-A8	ZPY3-◆◆-A8
ZPY□□□□-◆◆-B5	ZPY3-◆◆-B5
ZPY□□□□-◆◆-B6	ZPY3-◆◆-B6
ZPY□□□□-◆◆-B8	ZPY3-◆◆-B8

Note) Vacuum entry (◆◆): N4, N6, U4, U6

Applicable pad diameter: $\varnothing 40$, $\varnothing 50$

Model	① Adapter
ZPY□□□□-◆◆-A6	ZPY4-◆◆-A6
ZPY□□□□-◆◆-A8	ZPY4-◆◆-A8
ZPY□□□□-◆◆-B6	ZPY4-◆◆-B6
ZPY□□□□-◆◆-B8	ZPY4-◆◆-B8

Note) Vacuum entry (◆◆): N6, U6

Replacement Parts: Adapter/Buffer (Series ZPY)

● With buffer

— The same symbol
 ← Replacement of the symbol

[Pad model no.]

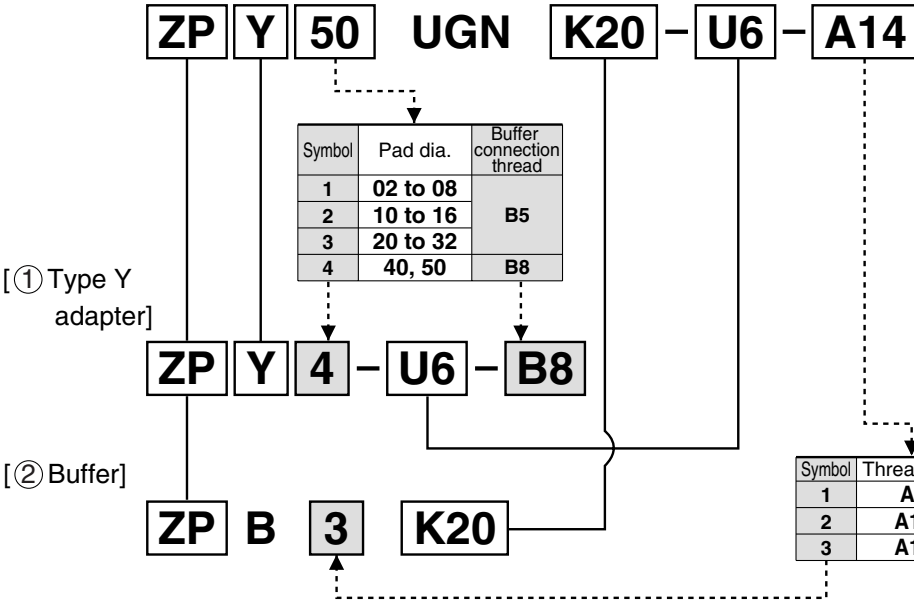

Construction

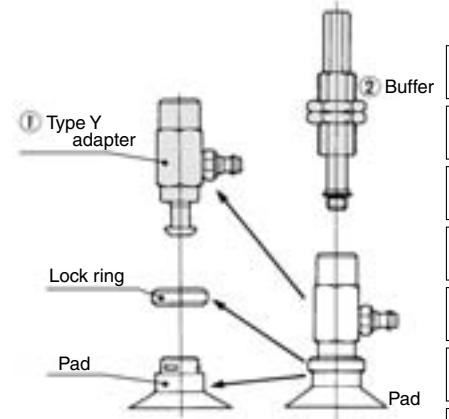

* Refer to ø2 to ø8 for Thin flat, Thin flat with ribs, and Elliptic.

Applicable pad diameter: ø2 to ø8
 2 x 4, 3.5 x 7, 4 x 10
 ø10 to ø16 (Thin section series)

Model	① Adapter	② Buffer
ZPY□□□□(J-K)★★-◆◆-A8	ZPY1-◆◆-B5	ZPB1(J-K)★★

Note 1) Applicable buffer stroke (★★): 6, 10, 15, 25 mm
 Note 2) Vacuum entry (◆◆): N4, N6, U4, U6

Applicable pad diameter: ø10 to ø16

Model	① Adapter	② Buffer
ZPY□□□□(J-K)★★-◆◆-A10	ZPY2-◆◆-B5	ZPB2(J-K)★★

Note 1) Applicable buffer stroke (★★): 10, 20, 30, 40, 50 mm
 Note 2) Vacuum entry (◆◆): N4, N6, U4, U6

Applicable pad diameter: ø20 to ø32

Model	① Adapter	② Buffer
ZPY□□□□(J-K)★★-◆◆-A10	ZPY3-◆◆-B5	ZPB2(J-K)★★

Note 1) Applicable buffer stroke (★★): 10, 20, 30, 40, 50 mm
 Note 2) Vacuum entry (◆◆): N4, N6, U4, U6

Applicable pad diameter: ø40, ø50

Model	① Adapter	② Buffer
ZPY□□□□(J-K)★★-◆◆-A14	ZPT4-B8	ZPB3(J-K)★★

Note 1) Applicable buffer stroke (★★): 10, 20, 30, 50 mm
 Note 2) Vacuum entry (◆◆): N6, U6

- ZA
- ZX
- ZR
- ZM
- ZMA
- ZQ
- ZH
- ZU
- ZL
- ZY□
- ZF□
- ZP□
- SP
- ZCUK
- AMJ
- AMV
- AEP
- HEP

Related Equipment